

VERSARACK + VERSAROLL

ASSEMBLY GUIDE



Intertek

Sanitation Listed
Certified to NSF/ANSI 2 by Intertek

-Size of parts will differ depending on customer's order.

-Quantity of parts might differ depending on customer's order.

NEED:



Two people
needed
PARTS LIST



1/2" Wrench & Ratchet with
1/2" Deep Well Socket



Level



Utility
Gloves

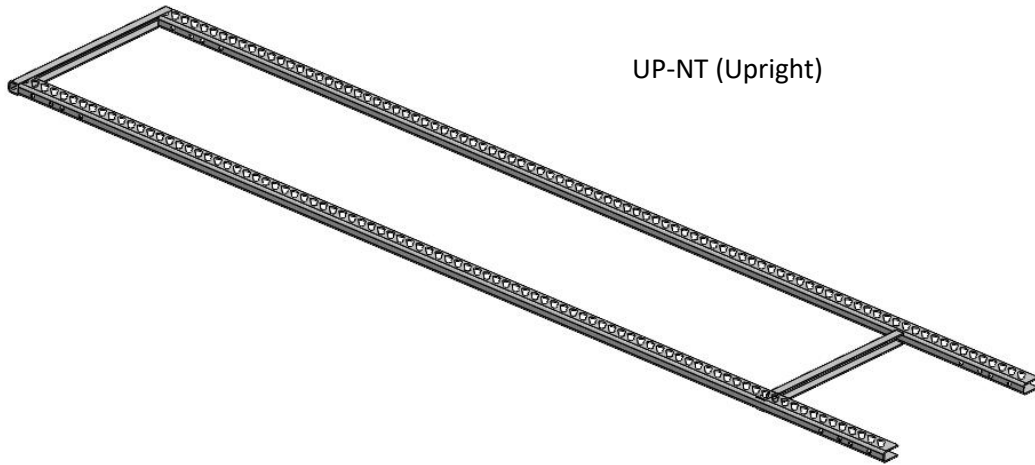

UP-NT (Upright)

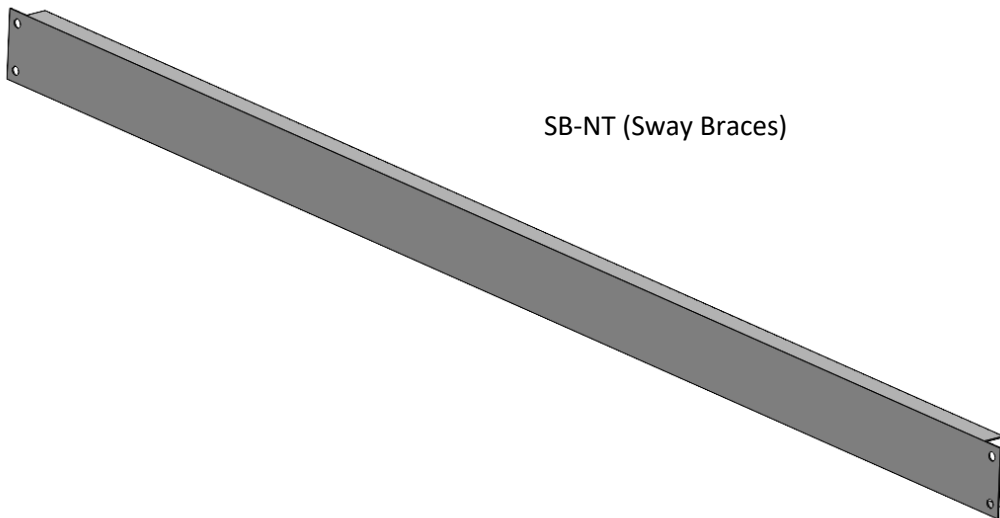

SB-NT (Sway Braces)

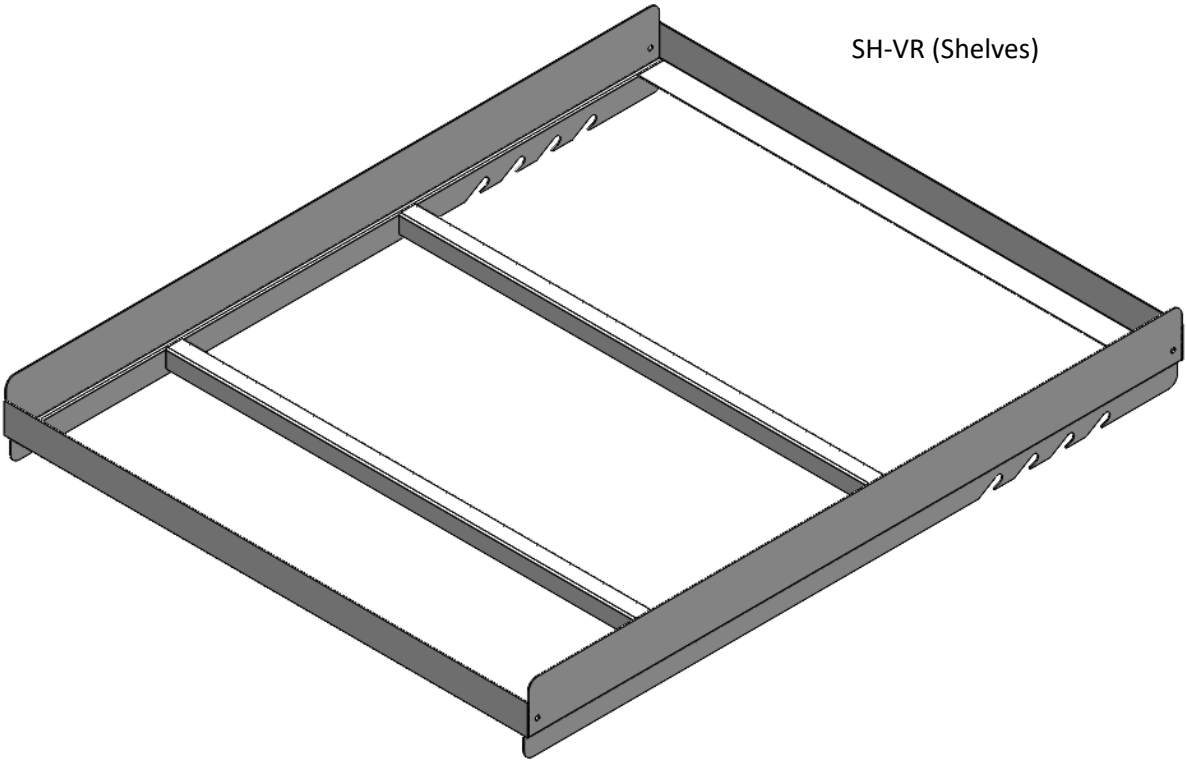

SH-VR (Shelves)

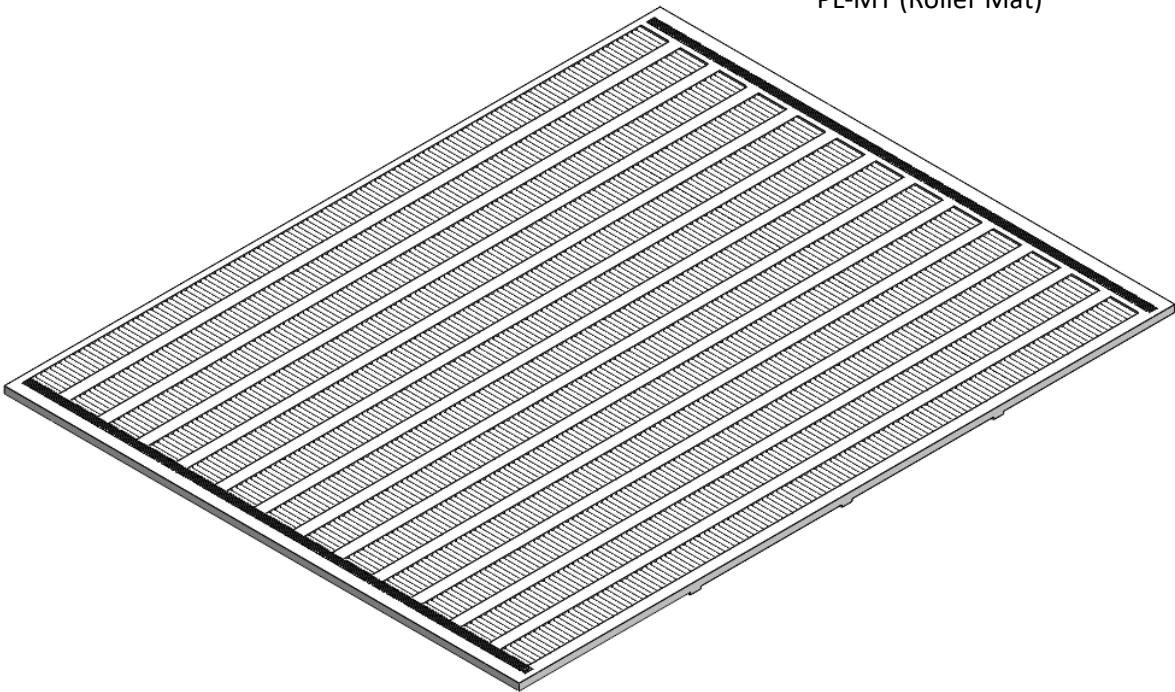

PL-MT (Roller Mat)

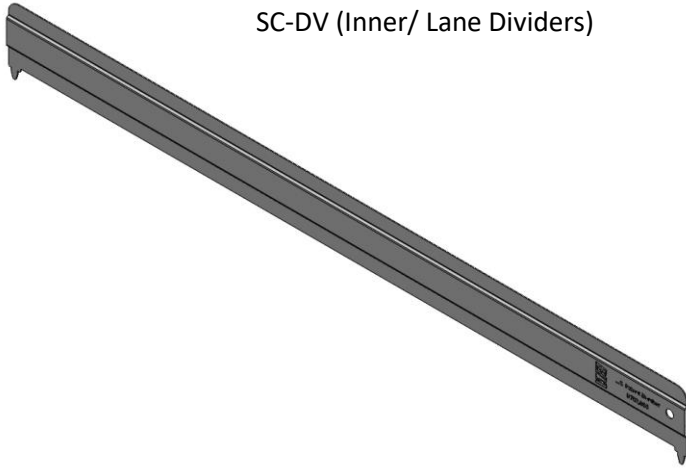

SC-DV (Inner/ Lane Dividers)

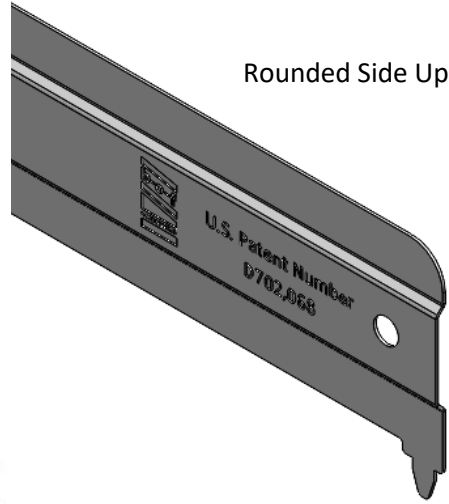

Rounded Side Up

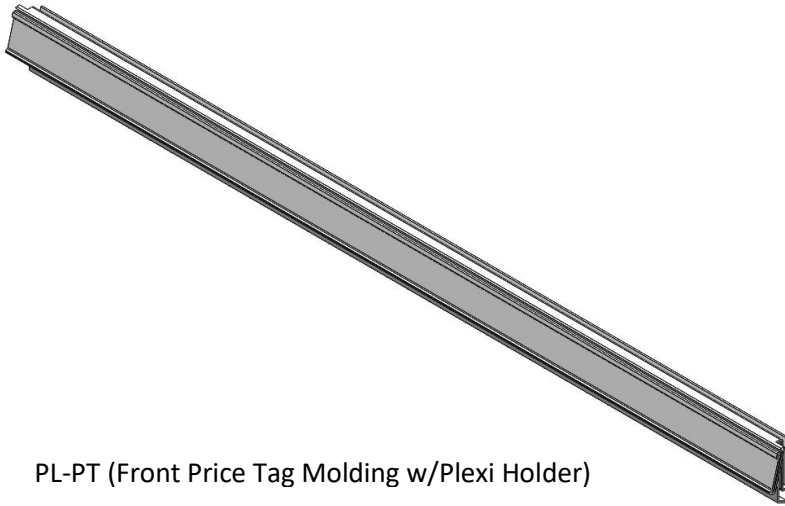

PL-PT (Front Price Tag Molding w/Plexi Holder)

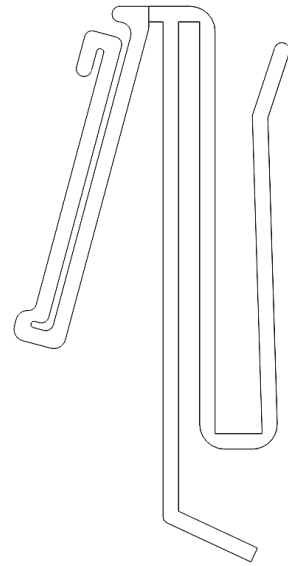

PL-PT (Rear Price Tag Molding)

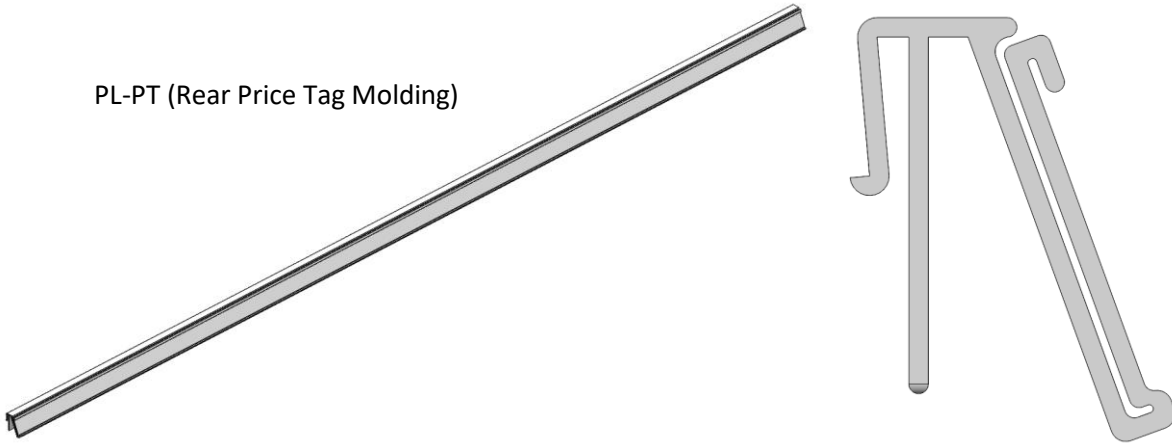

PL-PX (Plexiglass Front Product Stop)

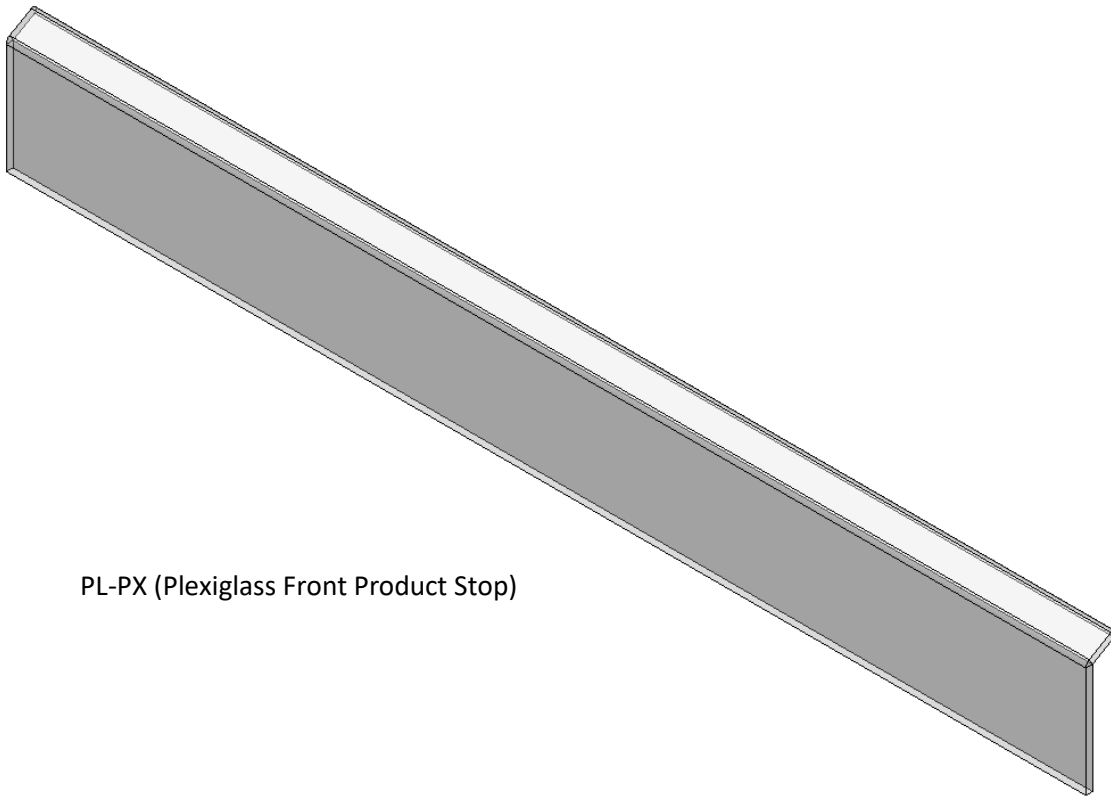

AE-FS (Filler Strips, only
in 4ft version)



MP-BM (Spacers)

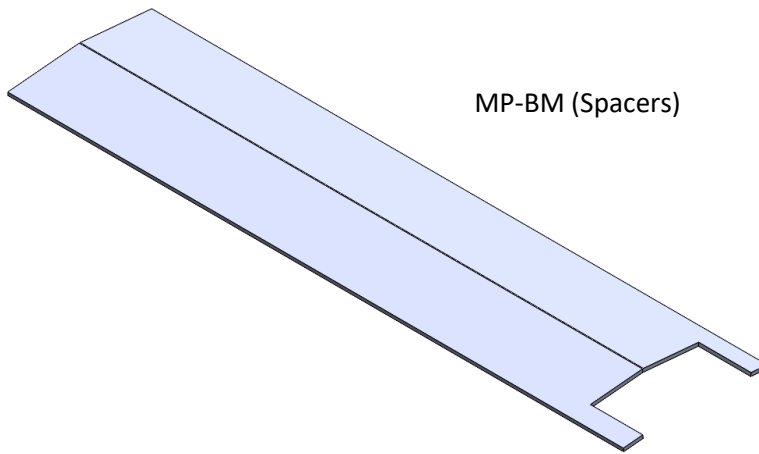

MH-CL
(Shelf Clamps)

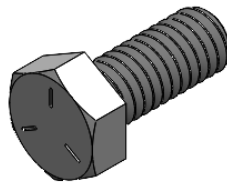

MH-BT
(5/16" Bolt)

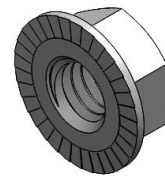

MH-NT
(Wiz Nut)

Step 1: Tighten with fingers, leave just finger tight until the end. Do **NOT** tighten with wrench until the end. Suggested location of sway braces are Top Front and Bottom Back. Each section must have 6 inches of sway brace.

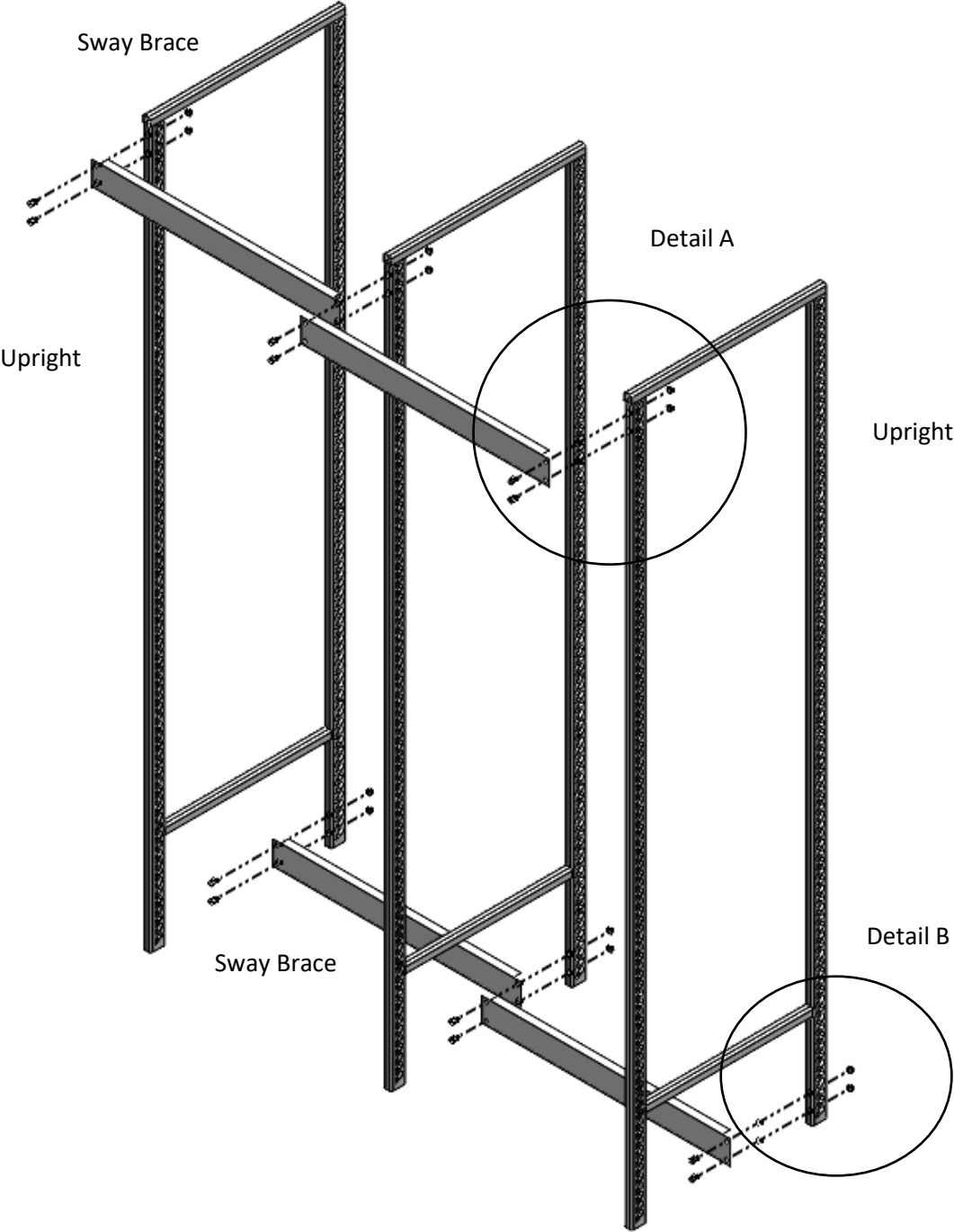

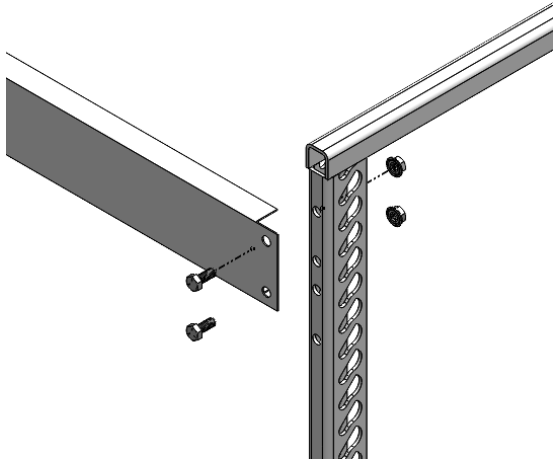

Detail A

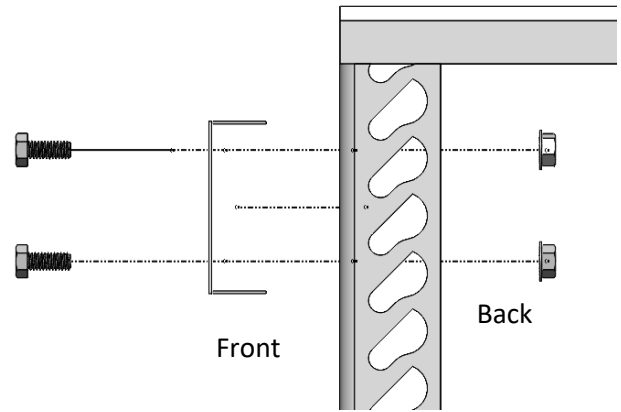

Sway Brace in the bottom will be attached using the 2 top holes

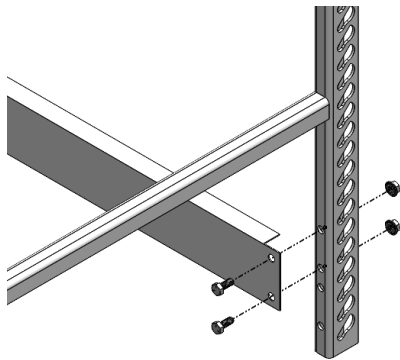

Detail B

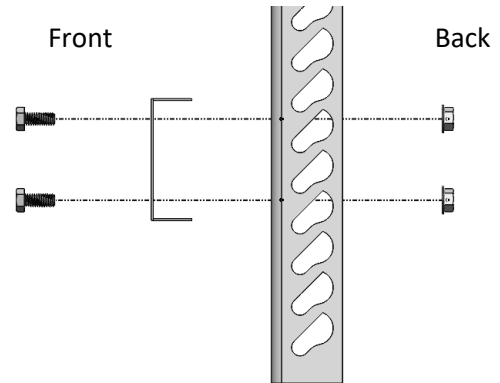

Door frames are done in 2, 3, 4 & 5 door sections, 5 is the maximum number of doors per section. Shelving frames must follow the door frames. The division between door frames will be seen by looking for a T-bar from the customer side of the doors, or by looking for where you see two lights on the merchandise side of the doors.

Front View

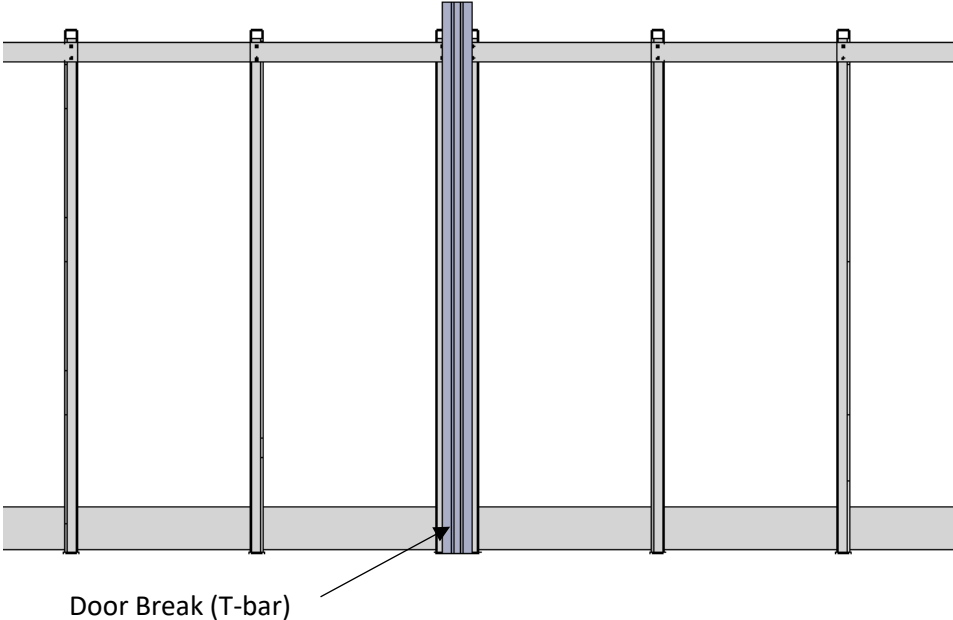

Top View

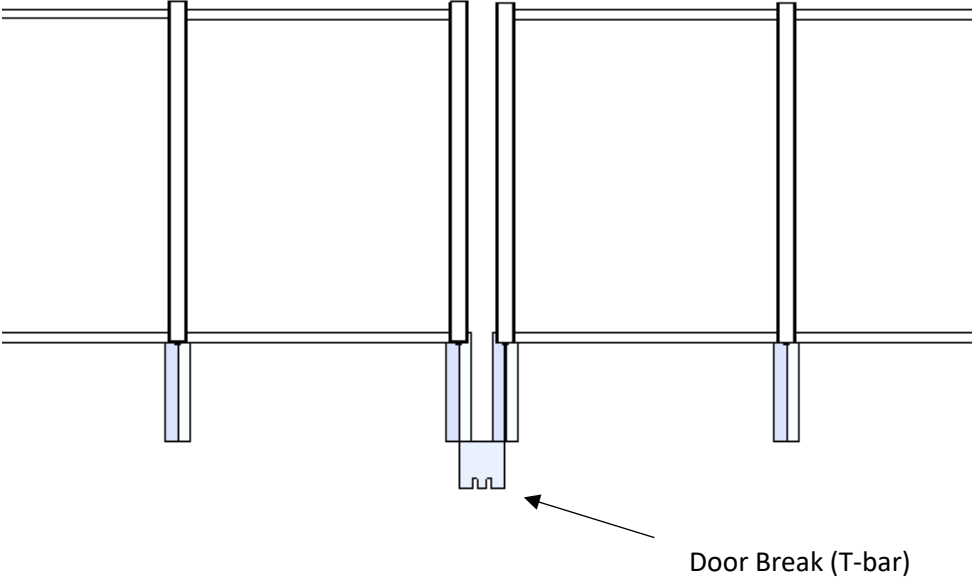

Step 2: Use spacers to set the clearance from the Frame to the door.

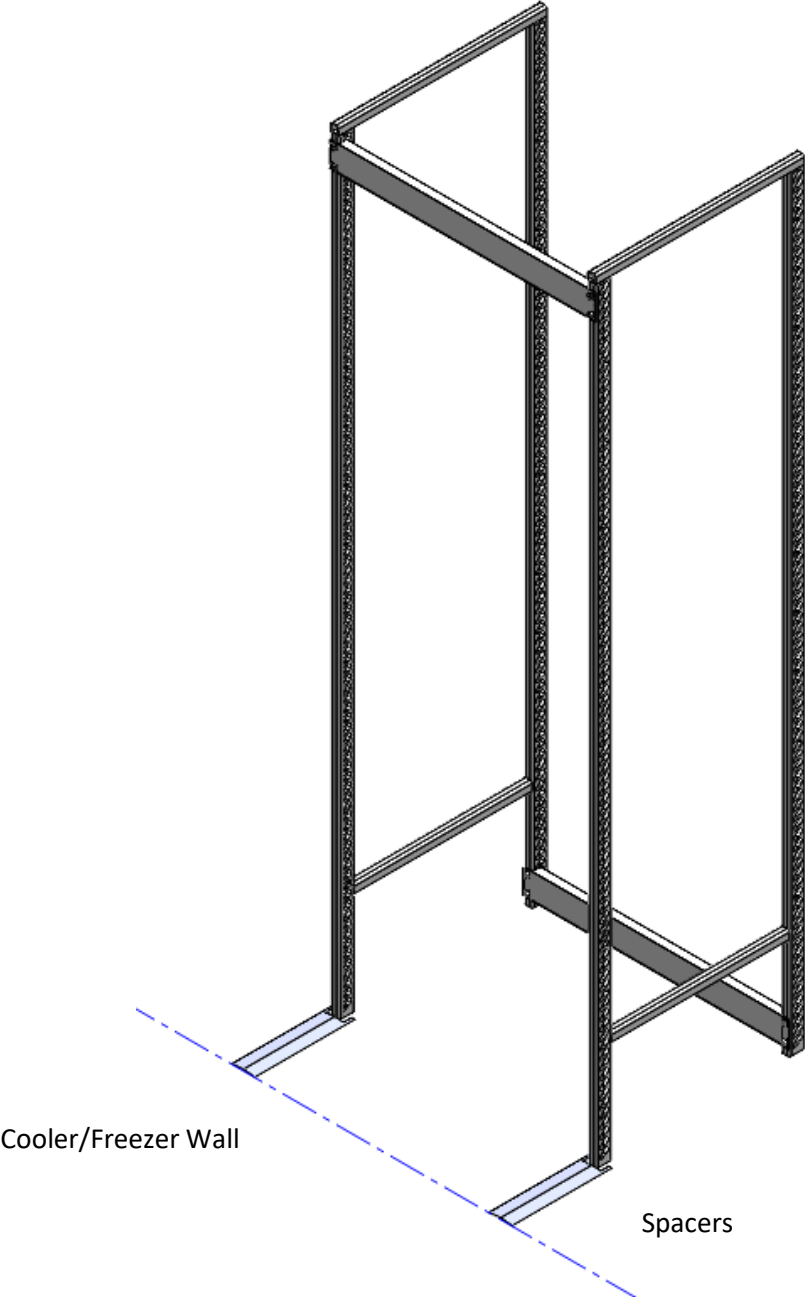

Step 3: Set Shelf clamps on the Upright frame to attach the Shelves.

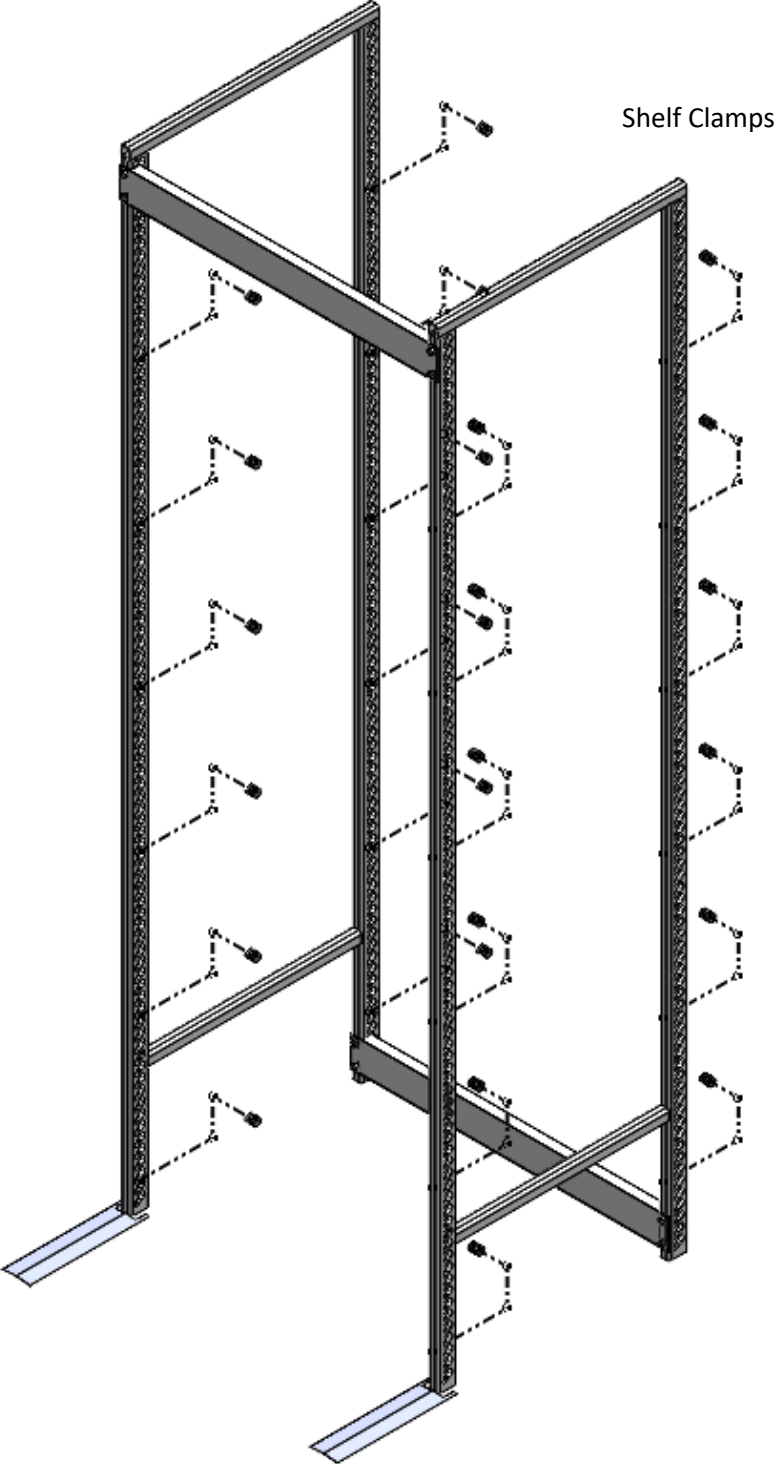

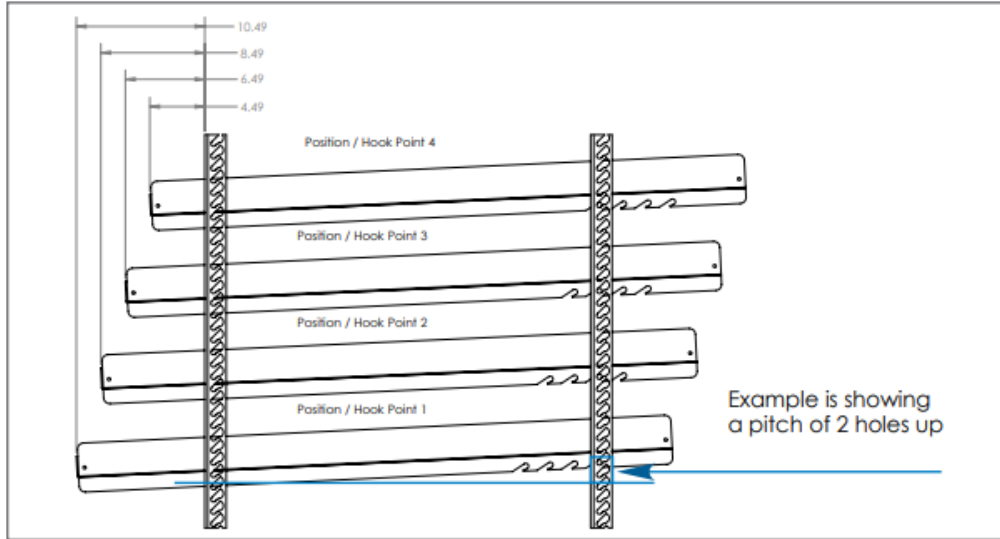

27" Shelf Depth

Product	Number of keyholes notches up
Plastic beverage	3
Carton beer	4
Cardboard water	4
Liquid dairy	3
Liquid dairy	4
Glass packaged	2

36" Shelf Depth

Product	Number of keyholes notches up
Plastic beverage	4
Carton beer	4
Cardboard water	4
Liquid dairy	4
Liquid dairy	4
Glass packaged	2

48" Shelf Depth

Product	Number of keyholes notches up
Plastic beverage	5
Carton beer	5
Cardboard water	5
Liquid dairy	5
Liquid dairy	5
Glass packaged	3

Step 4: Install top and bottom shelf frames **ONLY**. Use level to make sure rack is plumb.

Shelf Frames

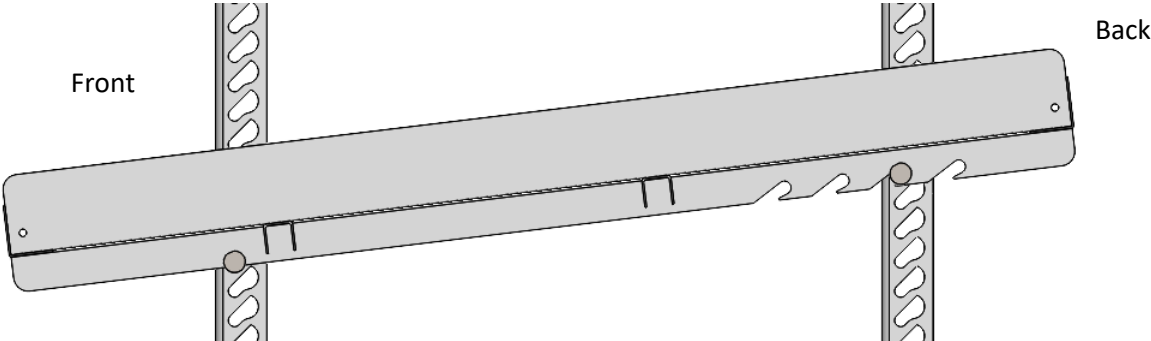
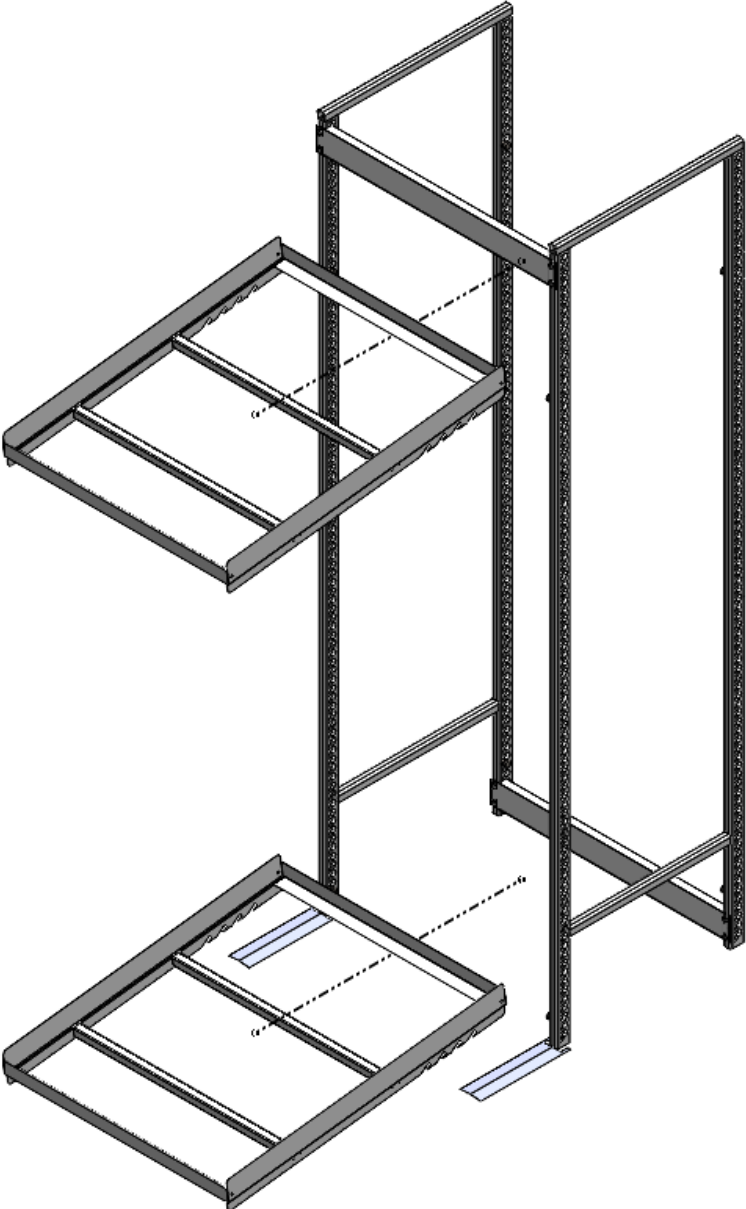

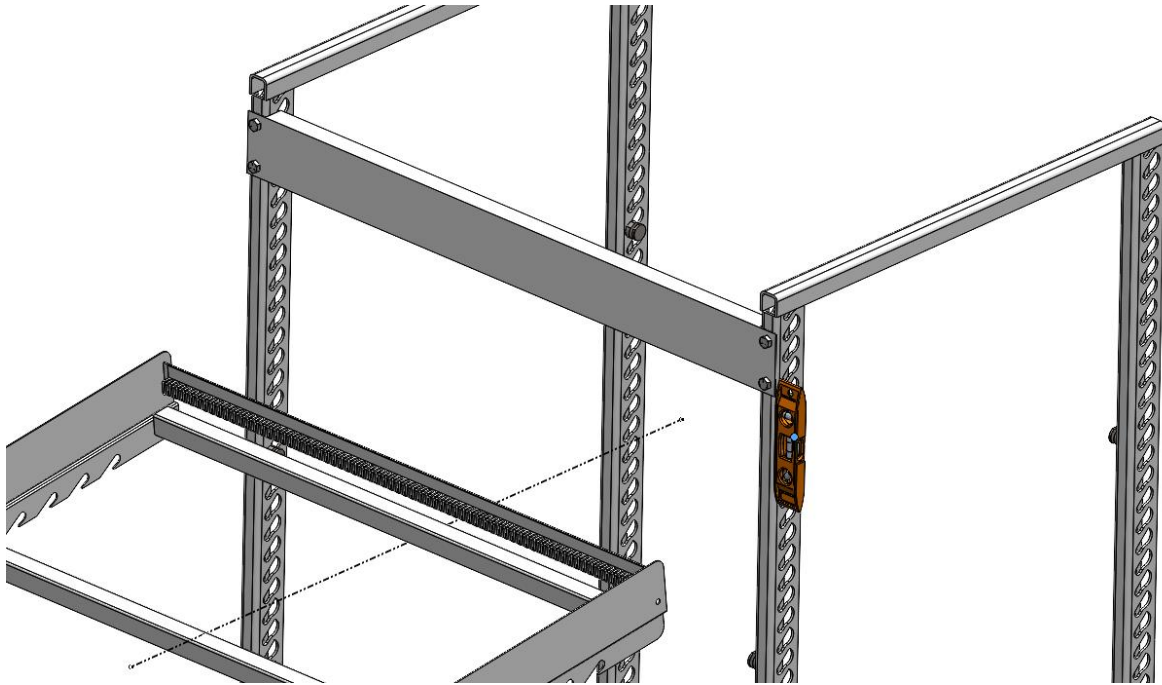

Step 5: **Tighten** all the bolts and nuts using the wrenches.

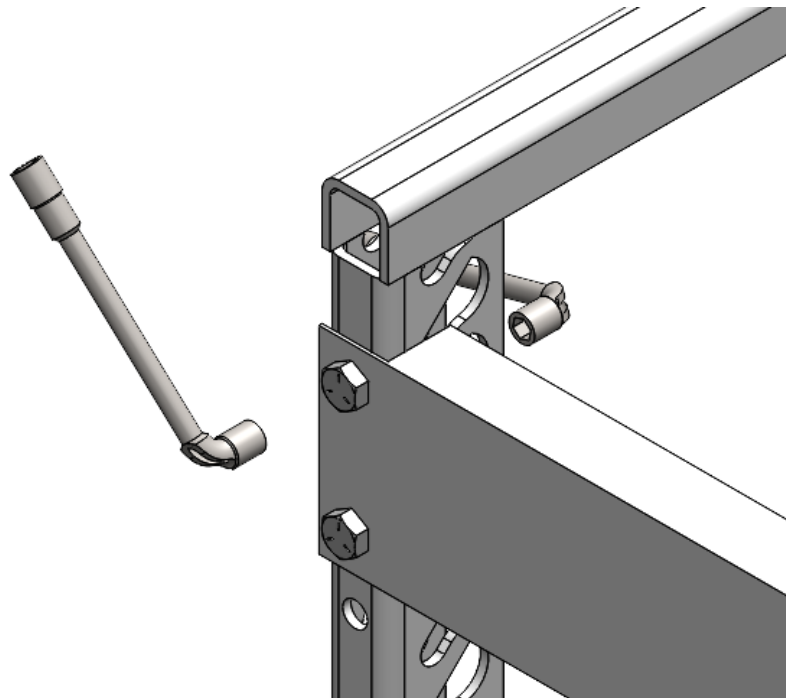

Step 6: Install remaining Shelf Frames.

Shelf Frames

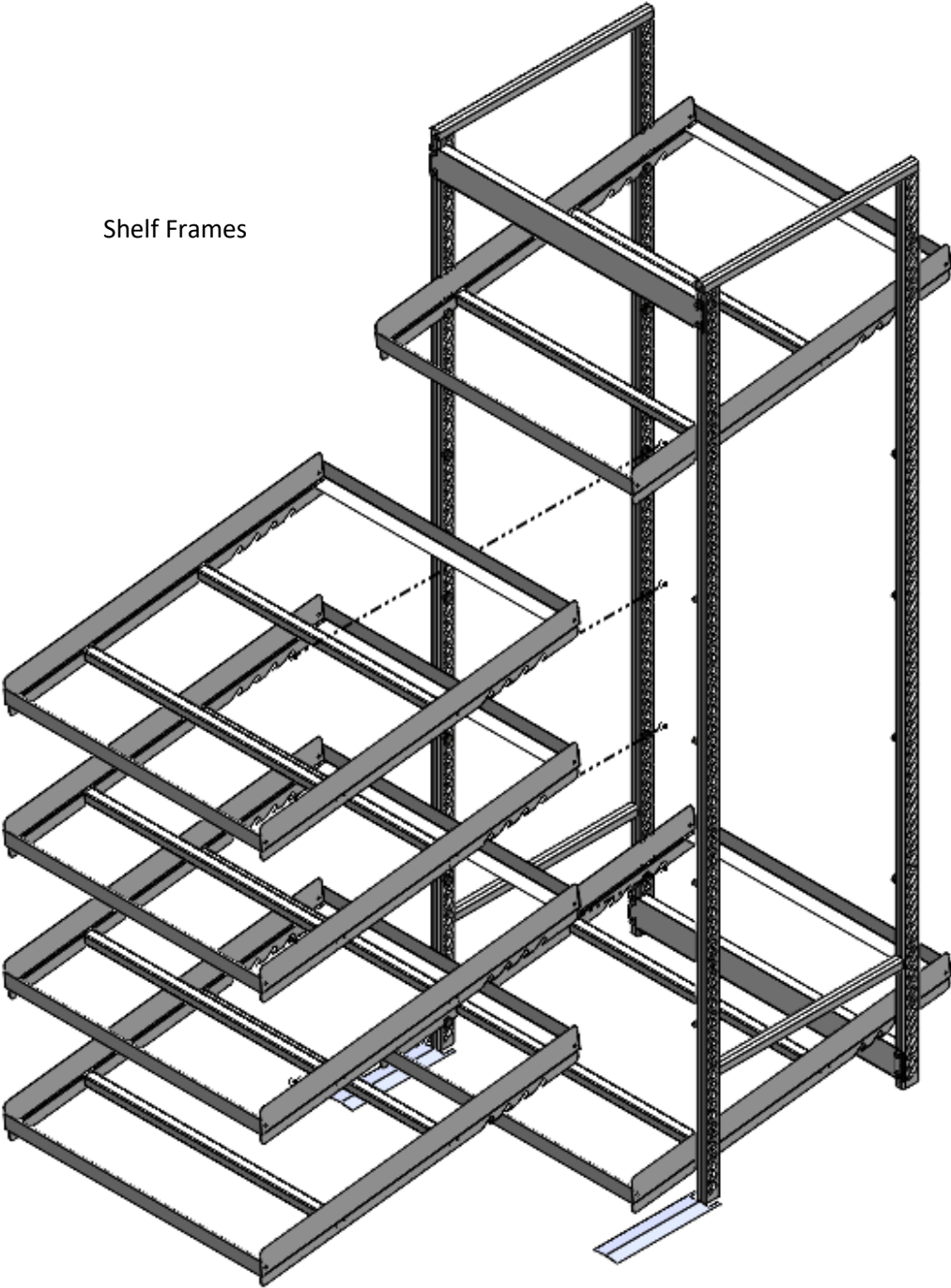

Step 7: Install Front/Rear Price Tag Molding.

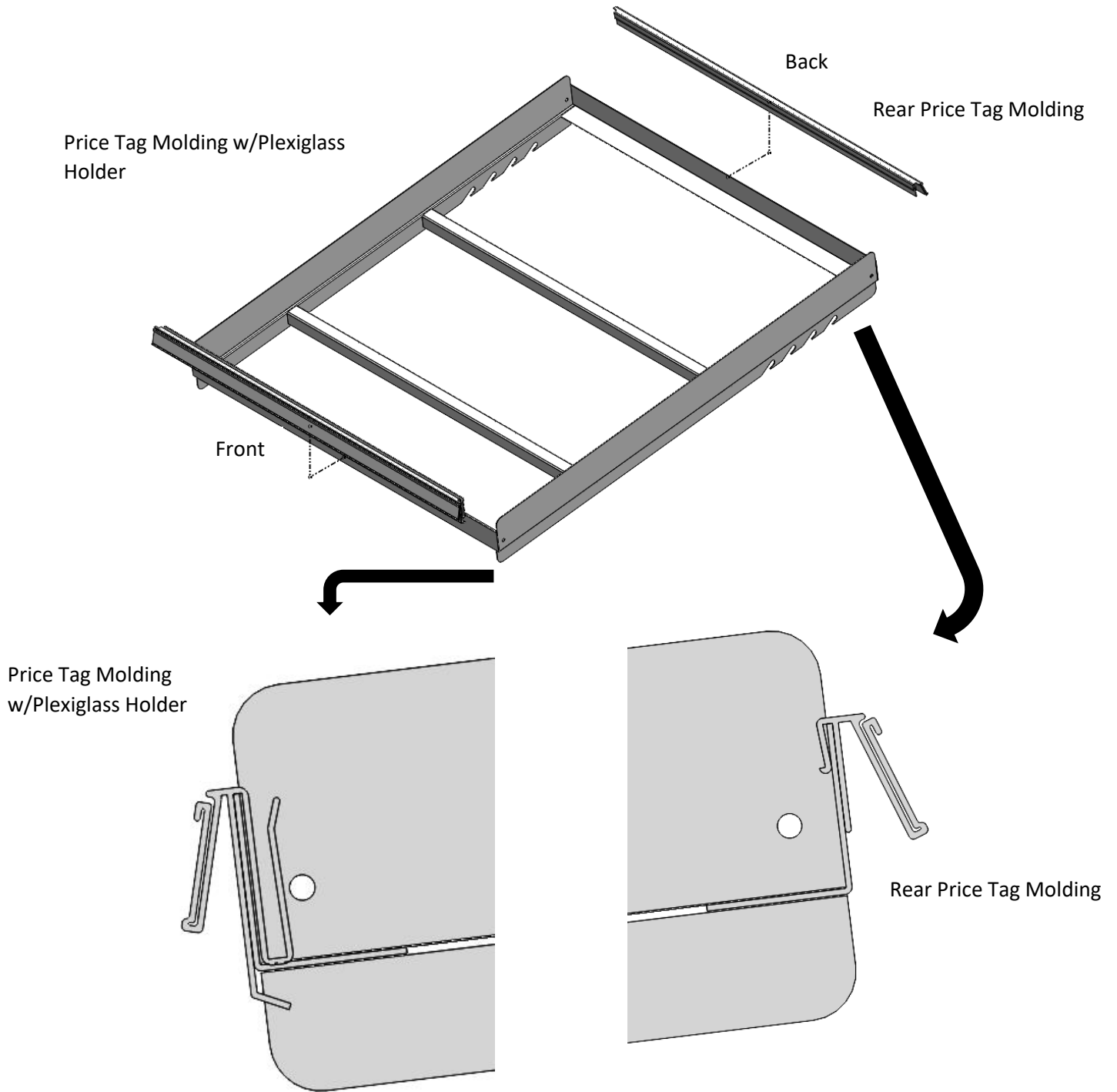

Step 8: Set Roller Mat on the Shelf Frame.

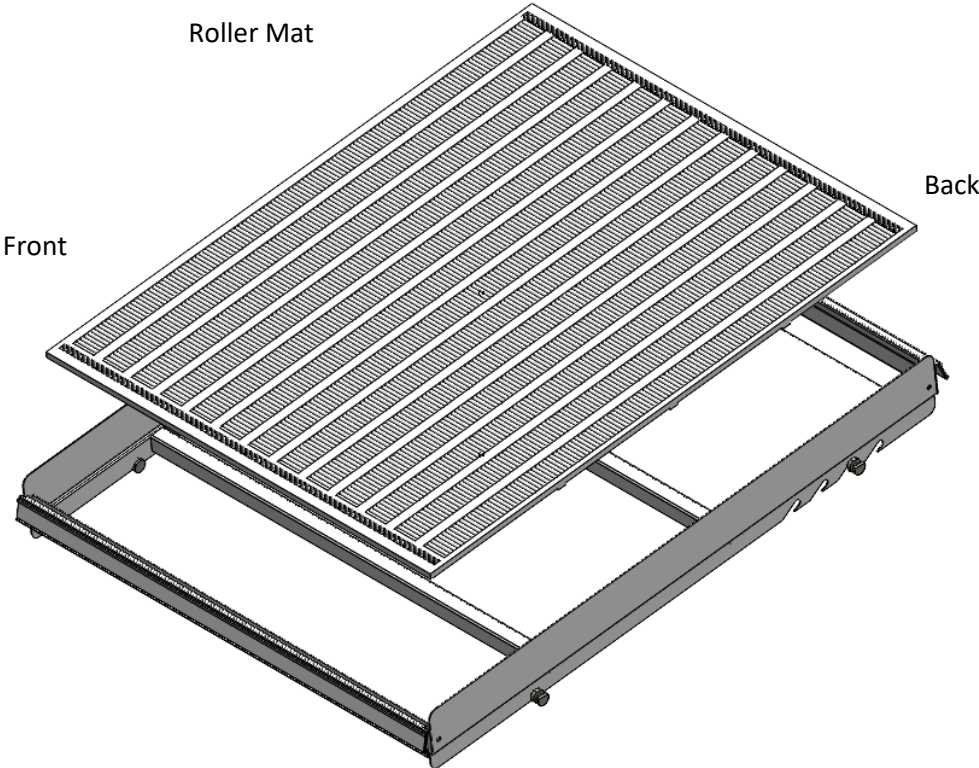

Optional: On 4ft Version is required to install a Filler Strip on the sides to secure the Roller Mat.

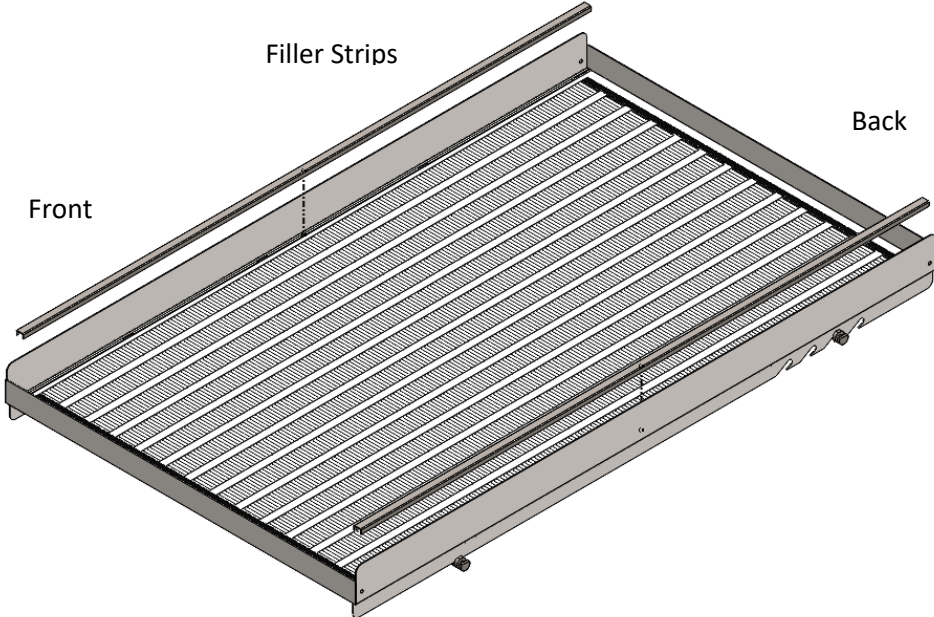

Step 9: Install Lane dividers as needed based upon product displayed.

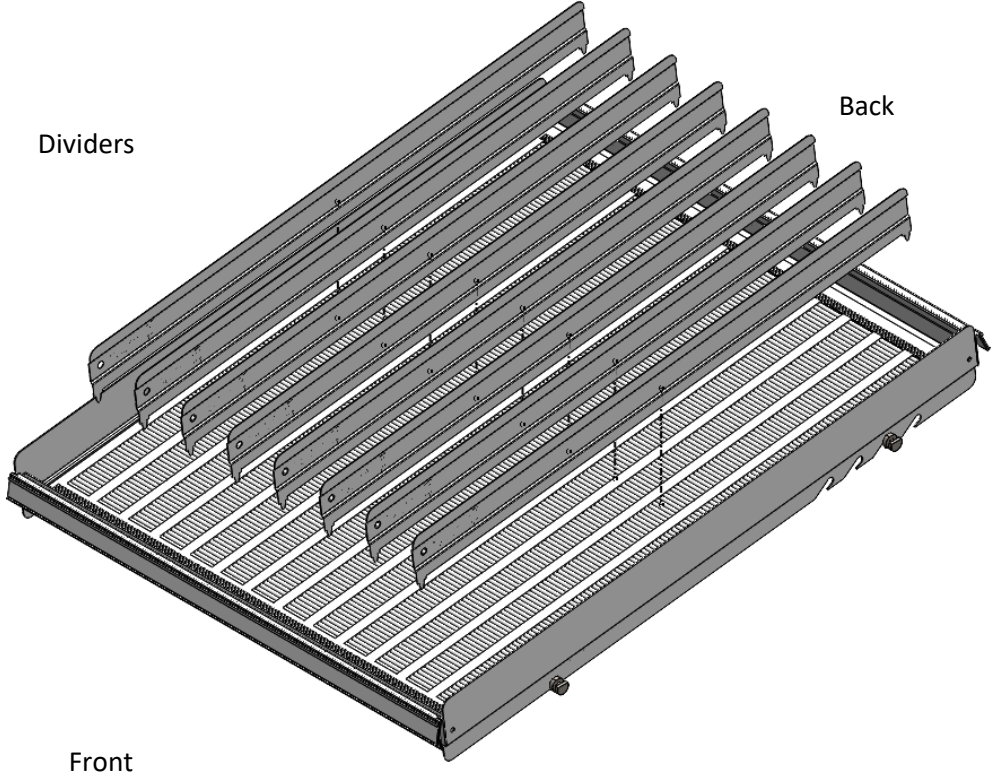

Dividers to be secure in the slots, round side must be up and all indents must go the same way in each shelf

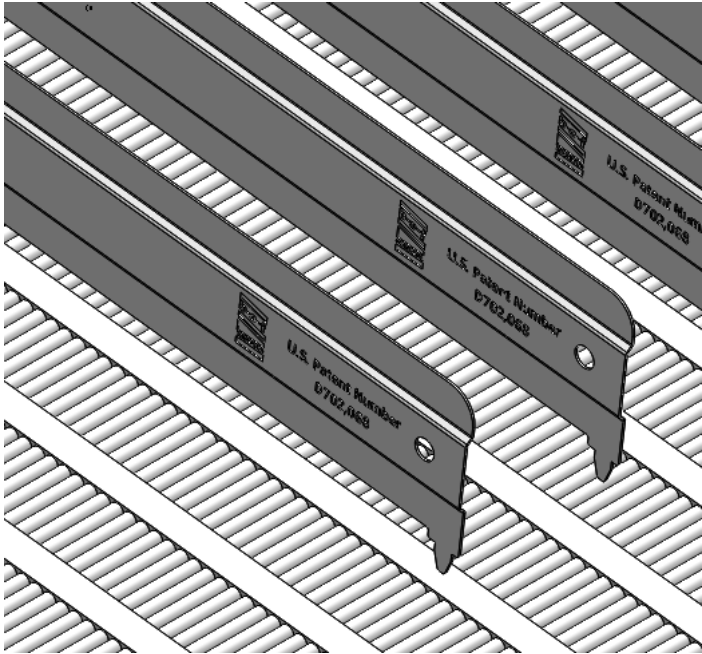

Laying two products down in each lane is a helpful way to set lane dividers.

Step 10: Install Plexiglass front product stop into the Front Price Tag Moldings w/ Plexi Holder slots.

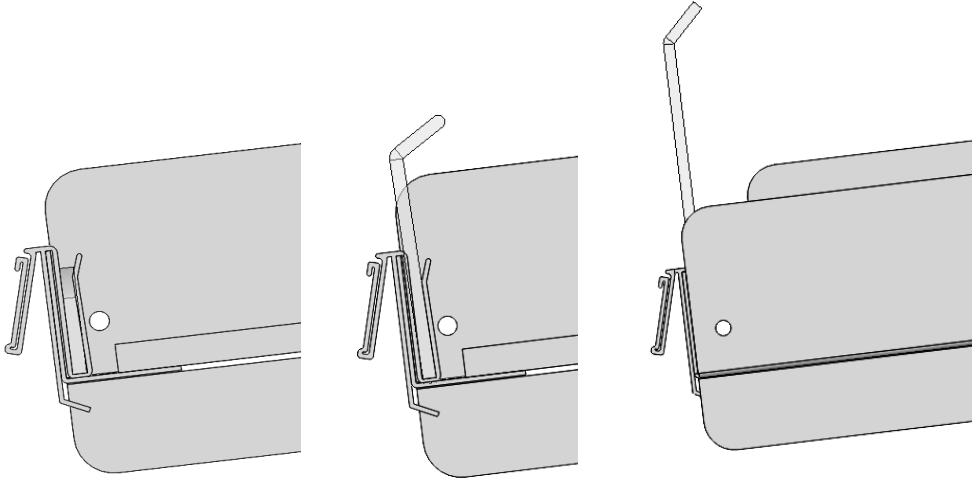
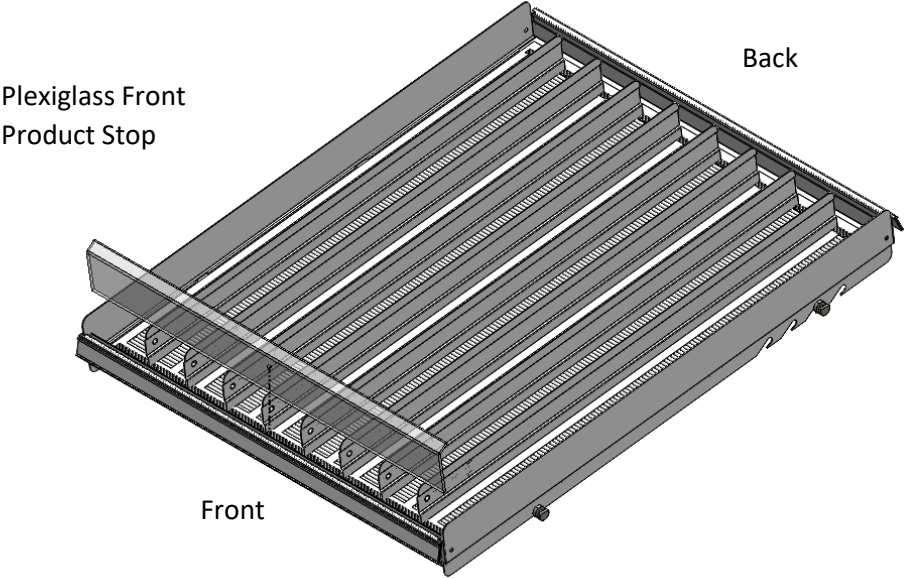

Filler

Standard

Tall (6 Inches)

Completed Assembly:

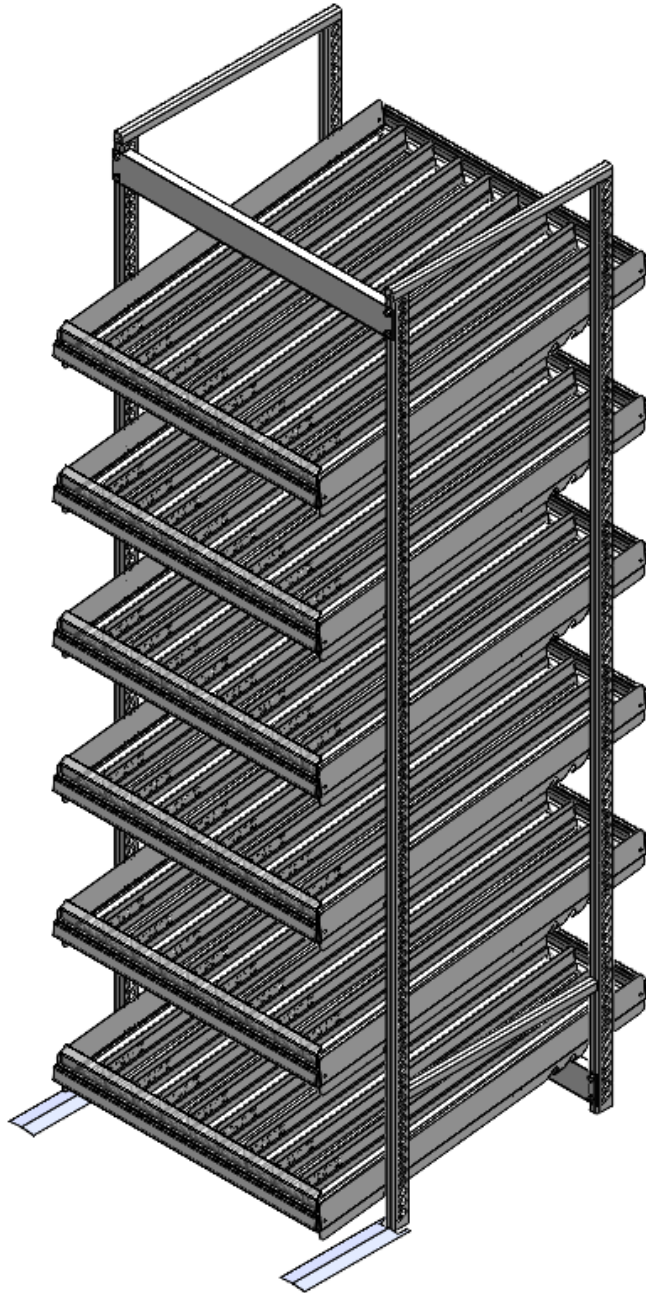

Questions?

Call Customer Service...800-323-2517

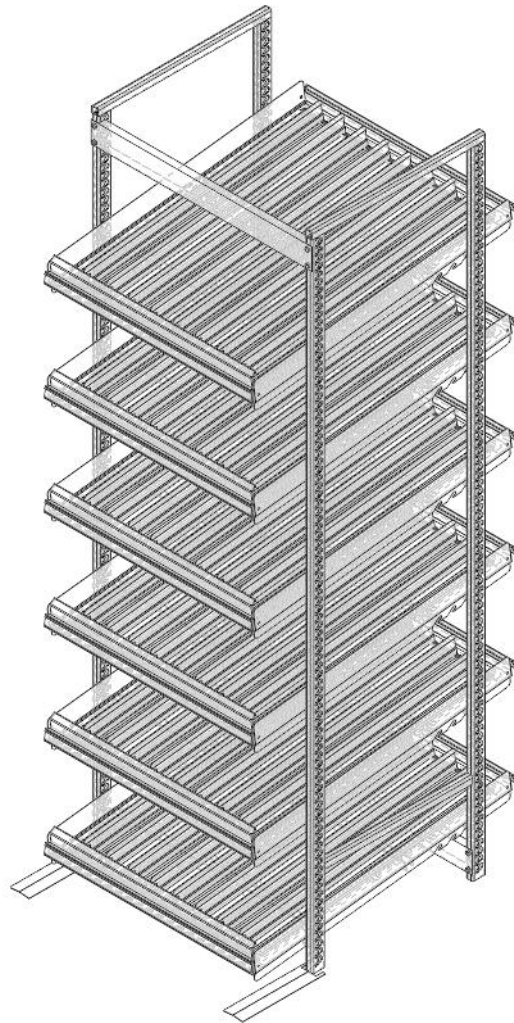

VERSARACK + VERSAROLL

GUÍA DE ENSAMBLAJE



Intertek

Sanitation Listed
Certified to NSF/ANSI 2 by Intertek

- Tamaño de partes pueden diferir dependiendo de la orden del cliente.
- Cantidad de partes pueden diferir dependiendo de la orden del cliente.

Requiere:



Dos personas



Llave de 1/2" & Ratchet con tubo profundo de 1/2"



Nivelador



Guantes de Trabajo

Lista de Partes

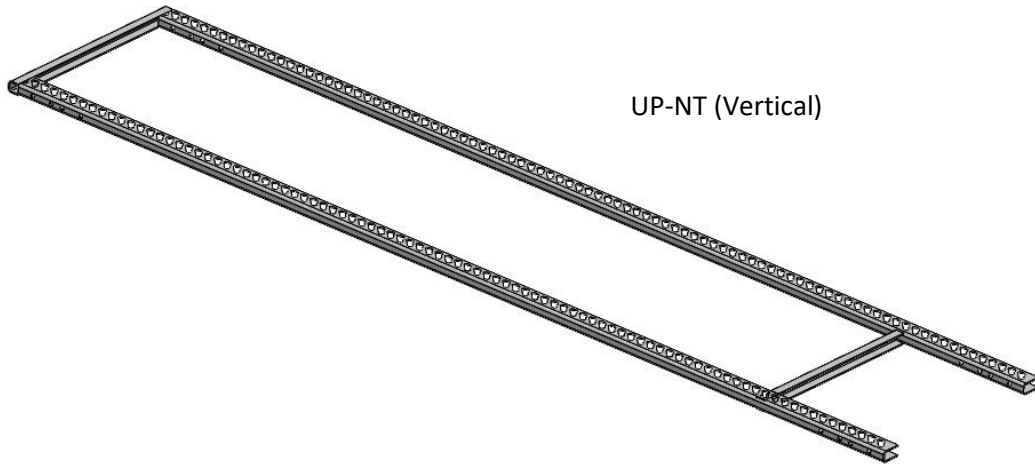

UP-NT (Vertical)

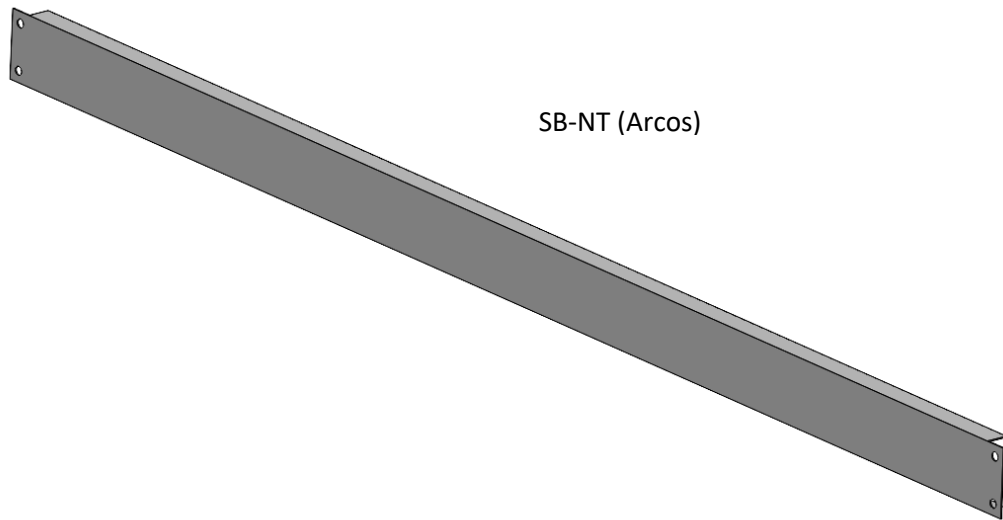

SB-NT (Arcos)

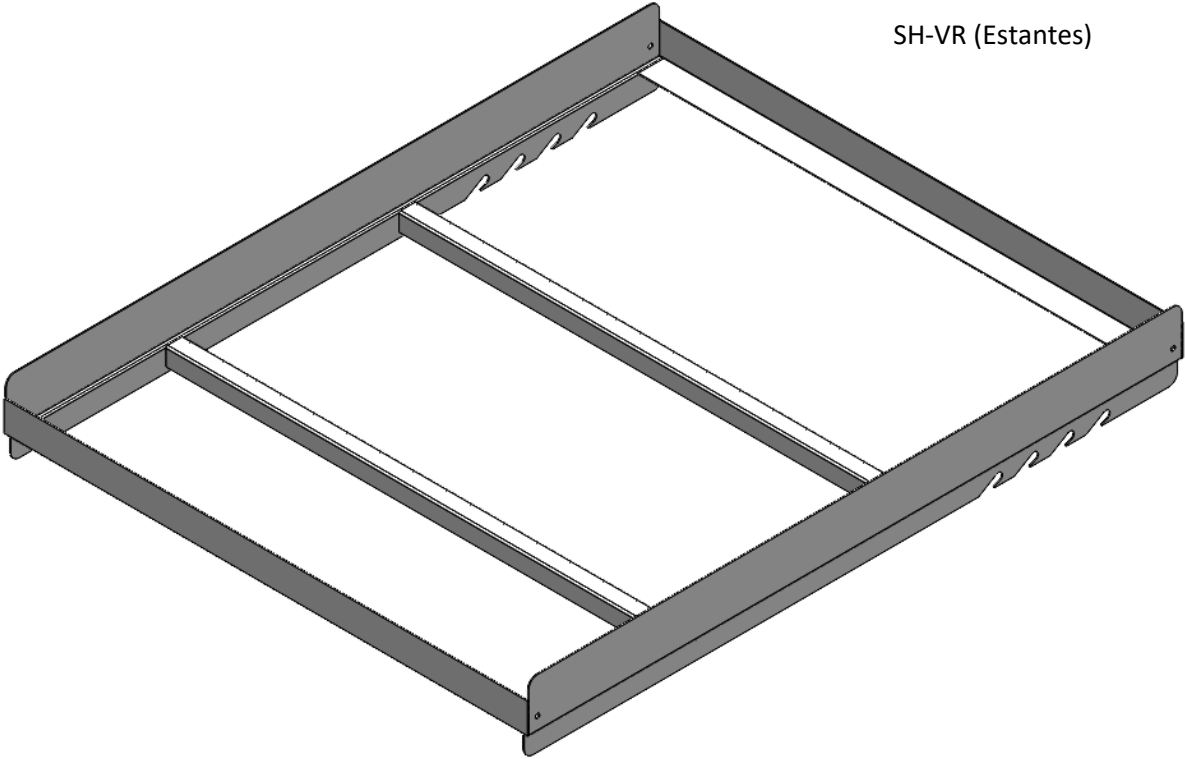

SH-VR (Estantes)

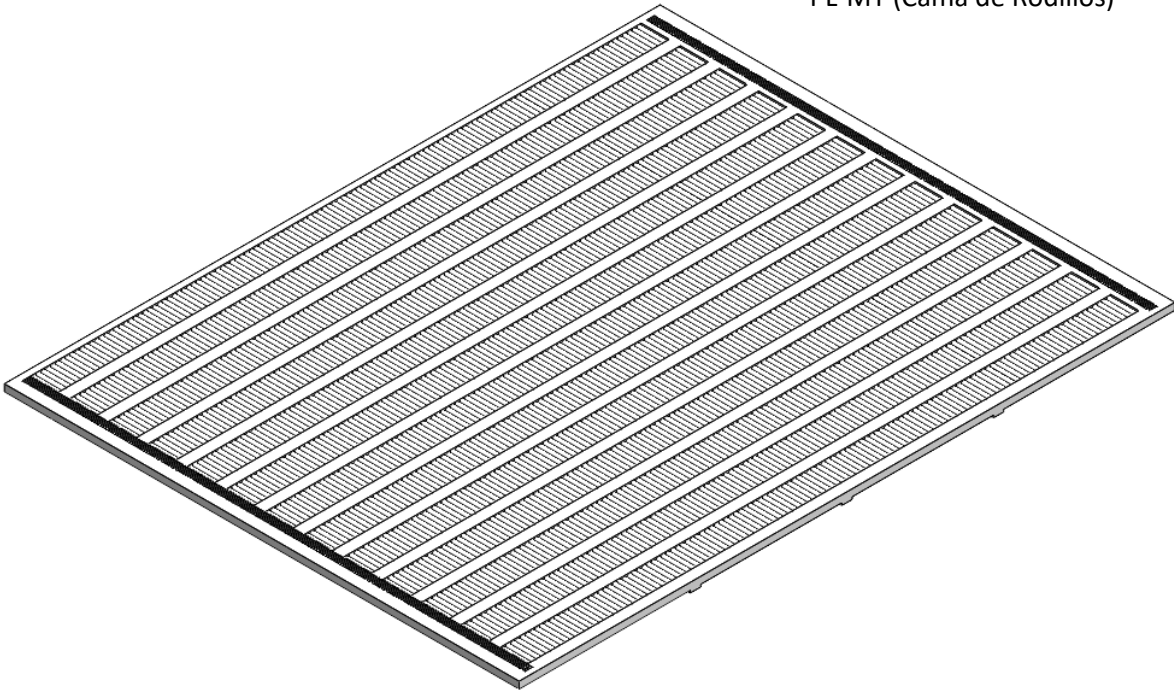

PL-MT (Cama de Rodillos)

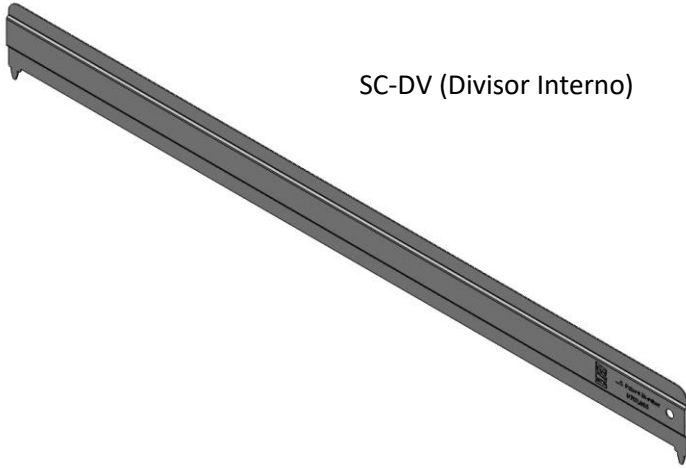

SC-DV (Divisor Interno)

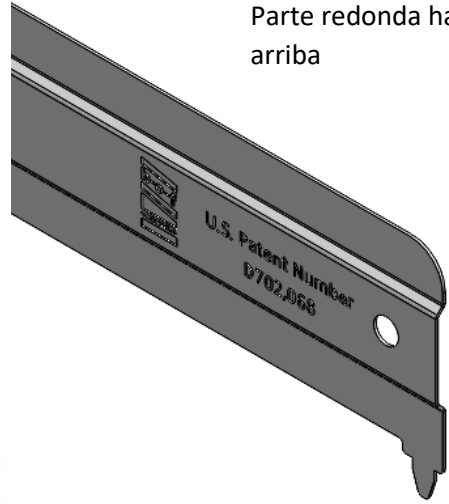

Parte redonda hacia arriba

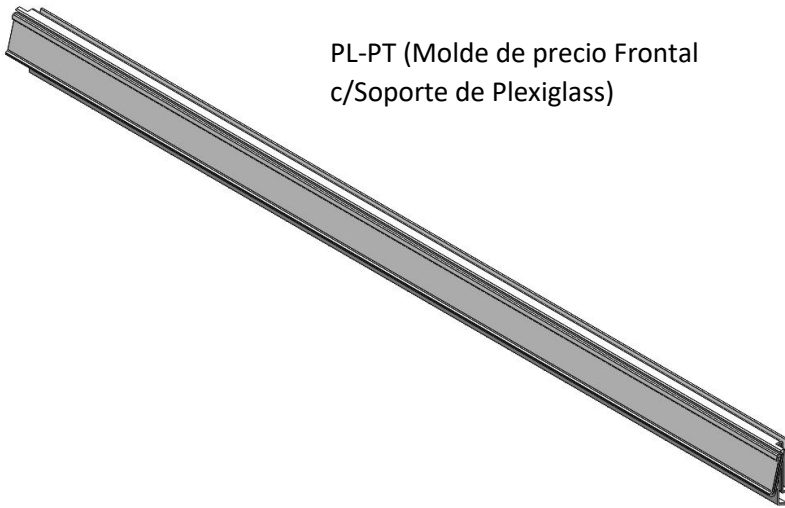

PL-PT (Molde de precio Frontal c/Soporte de Plexiglass)

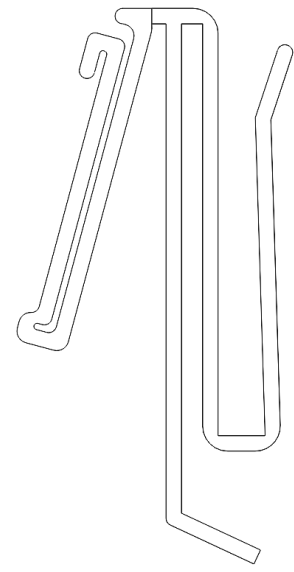

PL-PT (Molde de
precio Trasero)

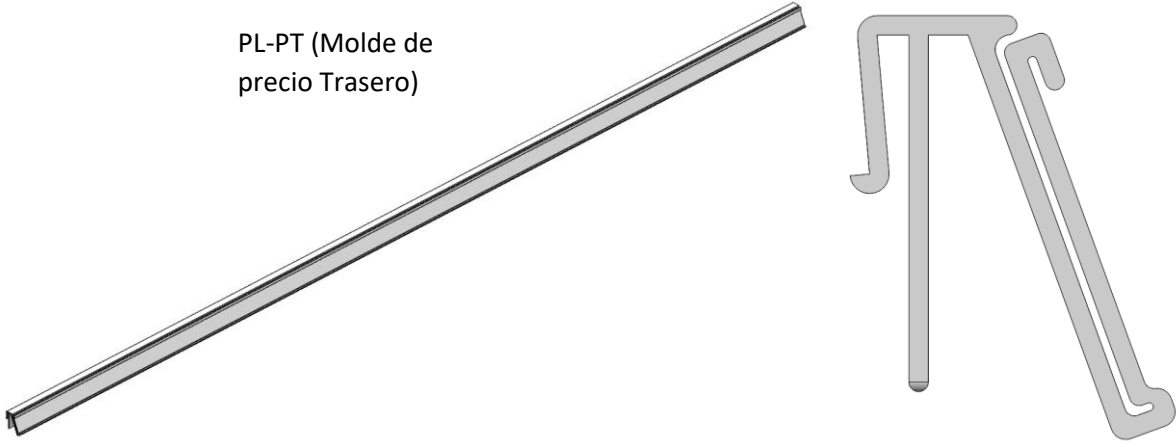

PL-PX (Plexiglass de parada
frontal de producto)

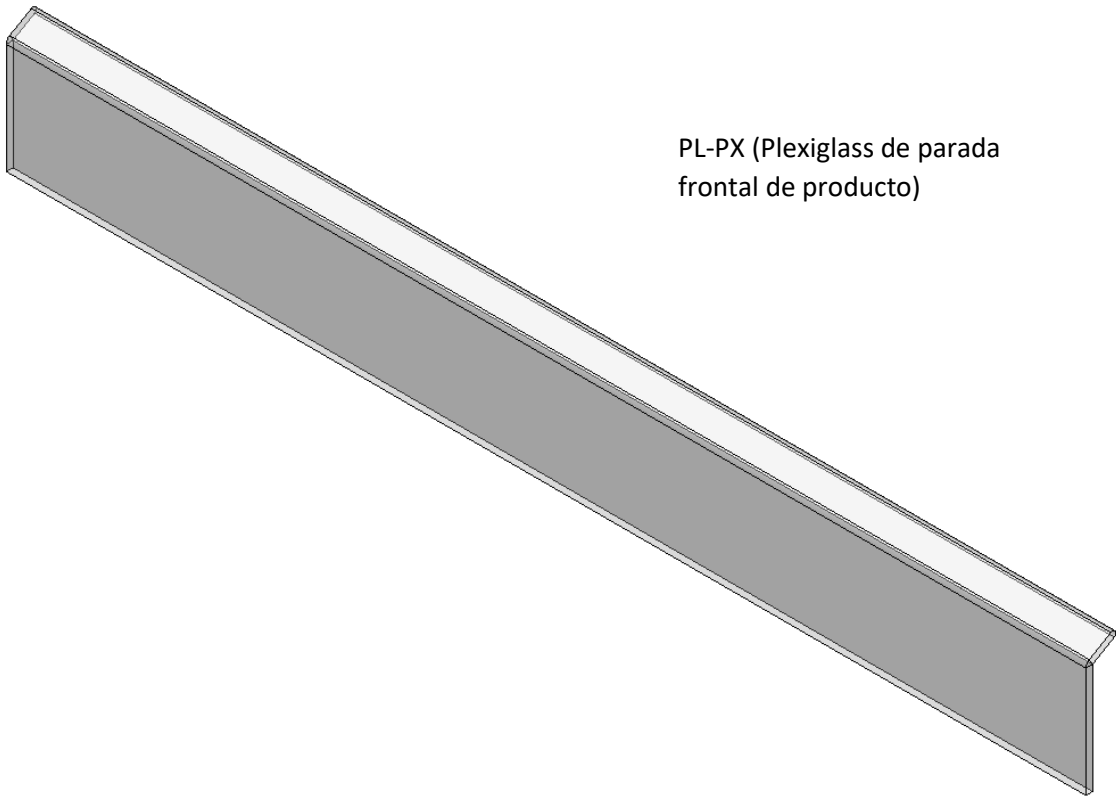

AE-FS (Tiras de relleno,
solo en estantes de 4



MP-BM (Separador)

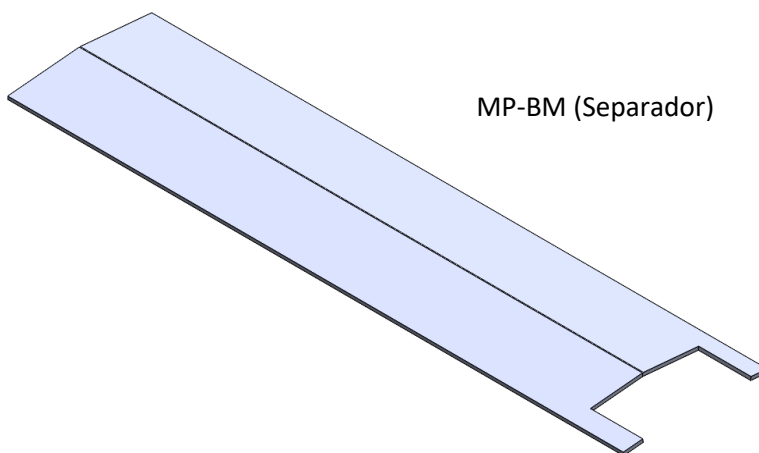

MH-CL
(Gancho de estante)

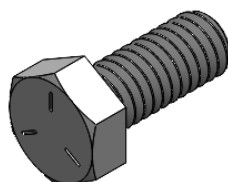

MH-BT
(Tornillo 5/16")

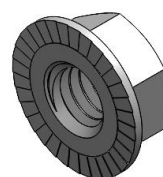

MH-NT
(Tuerca Serrada)

Paso 1: Apretar con los dedos, dejar las tuercas apretadas con los dedos. **NO** apretar con llaves hasta el final. Locación sugerida de arcos son frente superior y trasero inferior. Cada sección debe tener 6 pulgadas de arco.

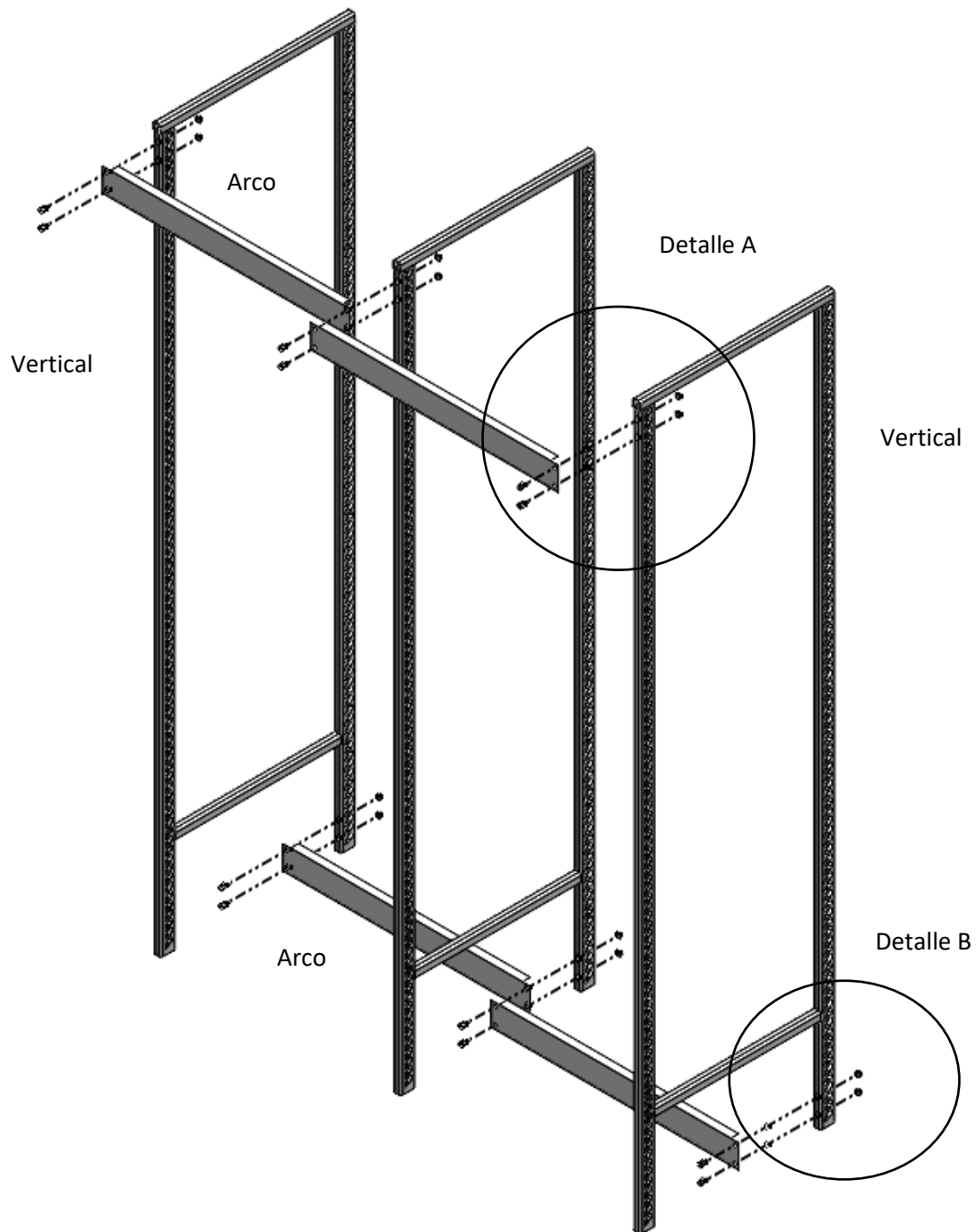

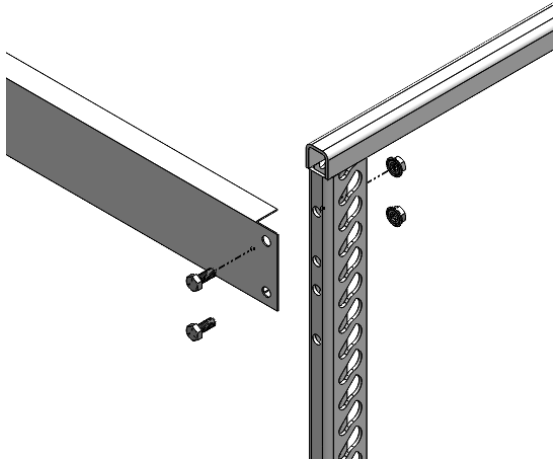

Detalle A

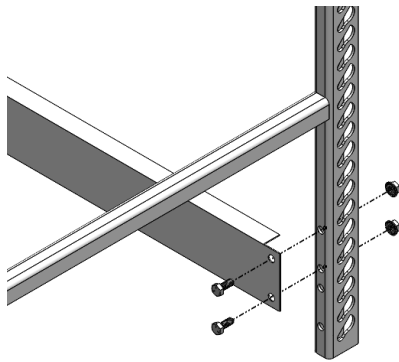
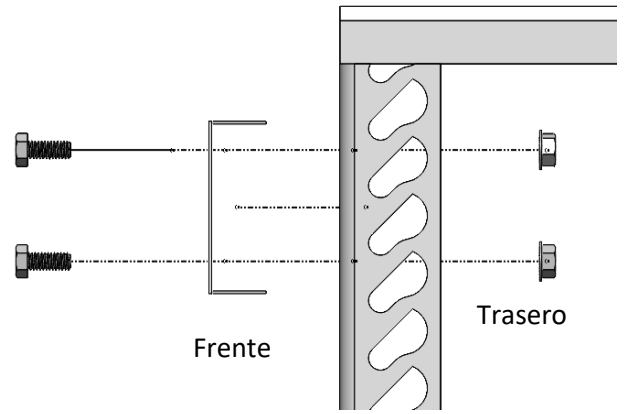

Detalle B

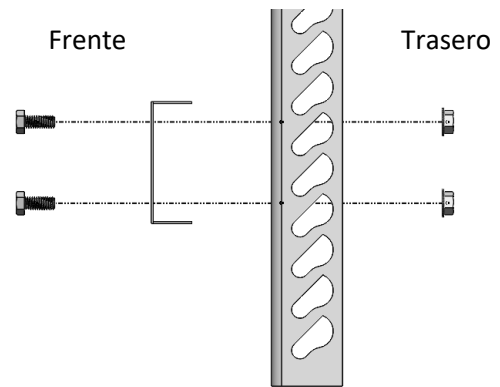

Los marcos de puerta vienen en 2, 3, 4 o 5 por sección, 5 es el máximo número de puertas por sección. Los marcos de estantes deben alinearse con los marcos de puertas. La división entre sección puede identificarse por una barra T desde el lado del cliente de las puertas, o donde puedas ver dos luces desde el lado del producto de las puertas.

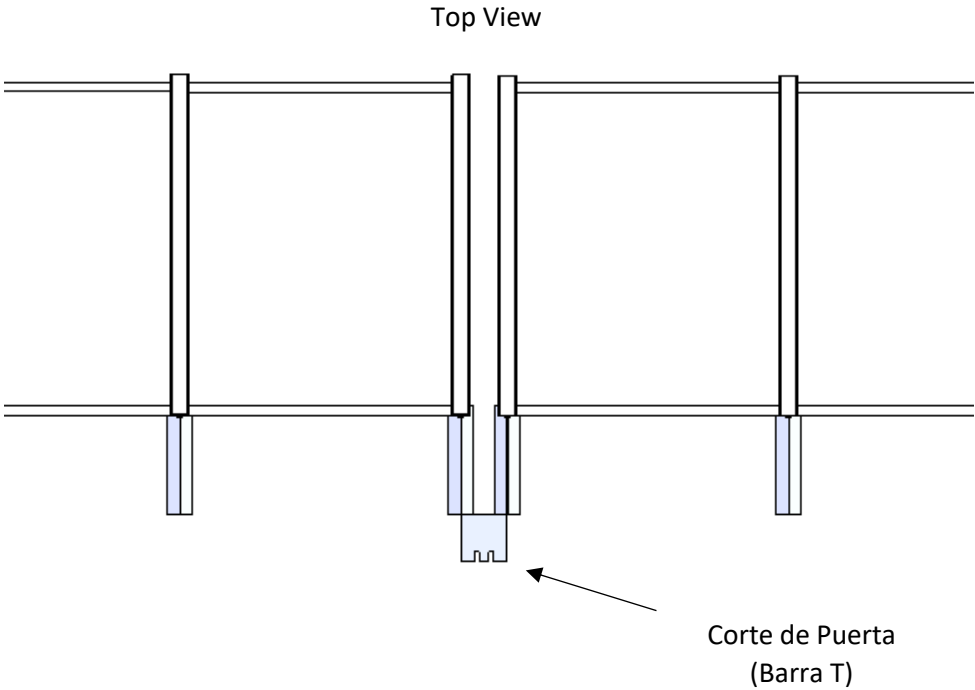
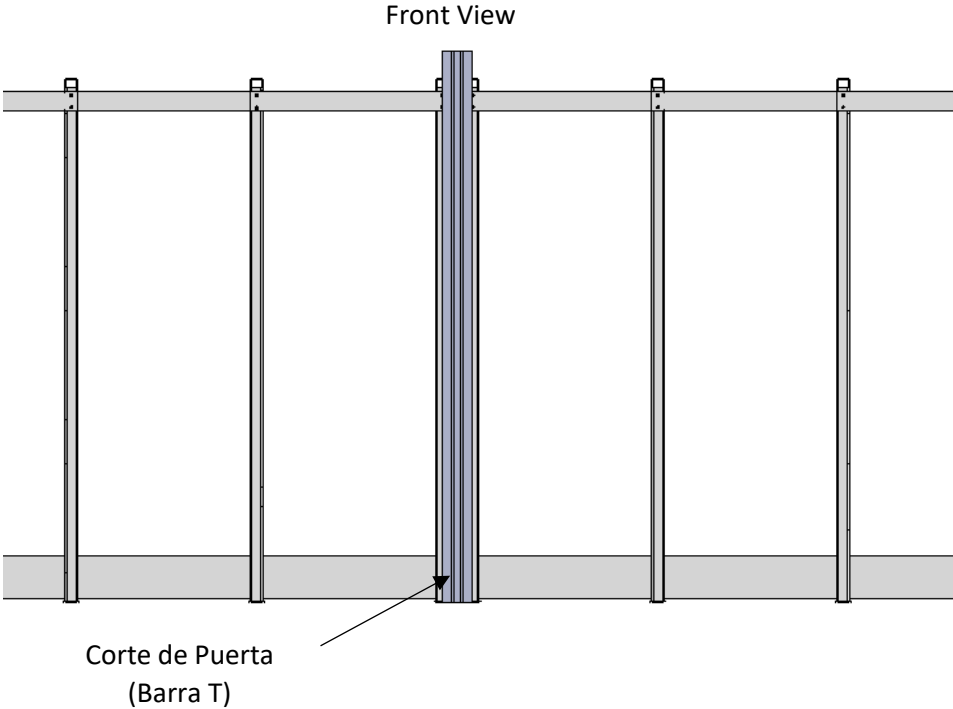

Paso 2: Use separadores para indicar el espacio del vertical de la puerta.

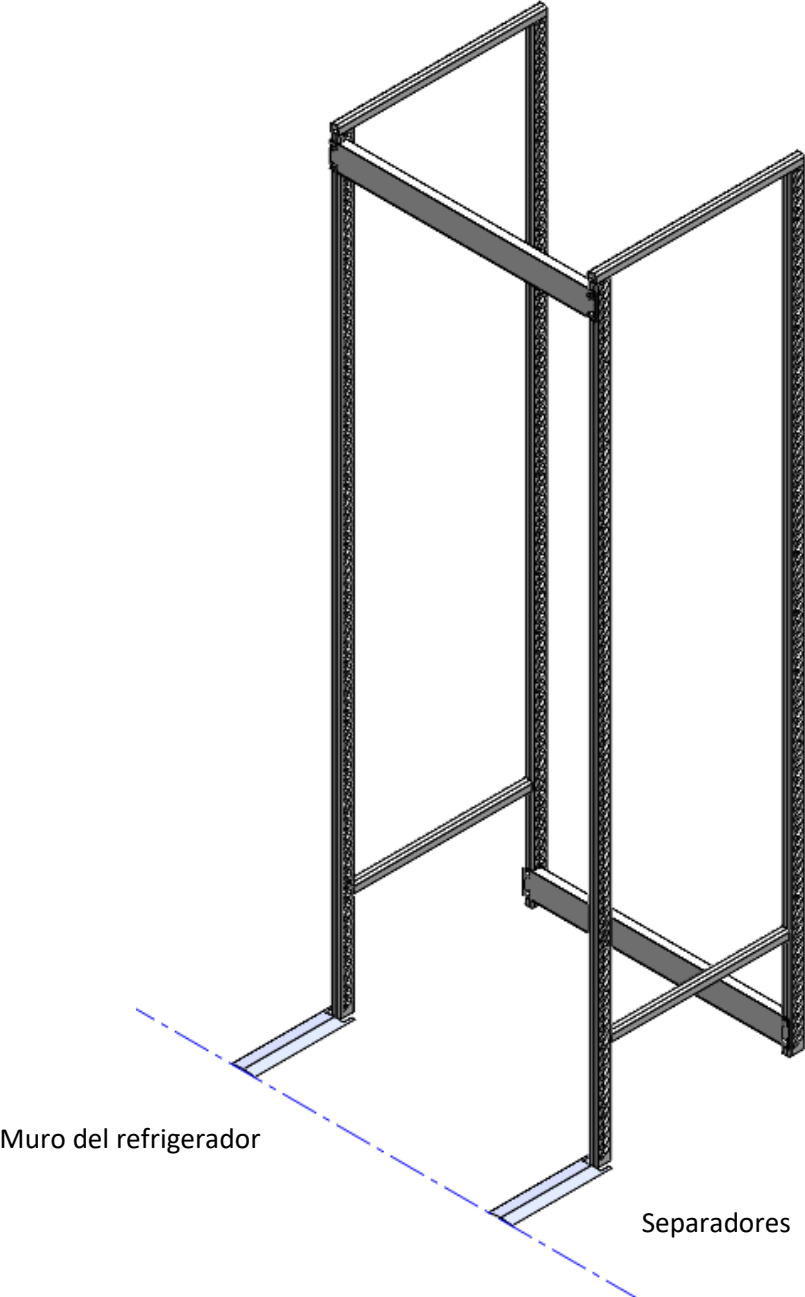

Paso 3: Coloque los ganchos de estantes en el marco del vertical para colocar los estantes.

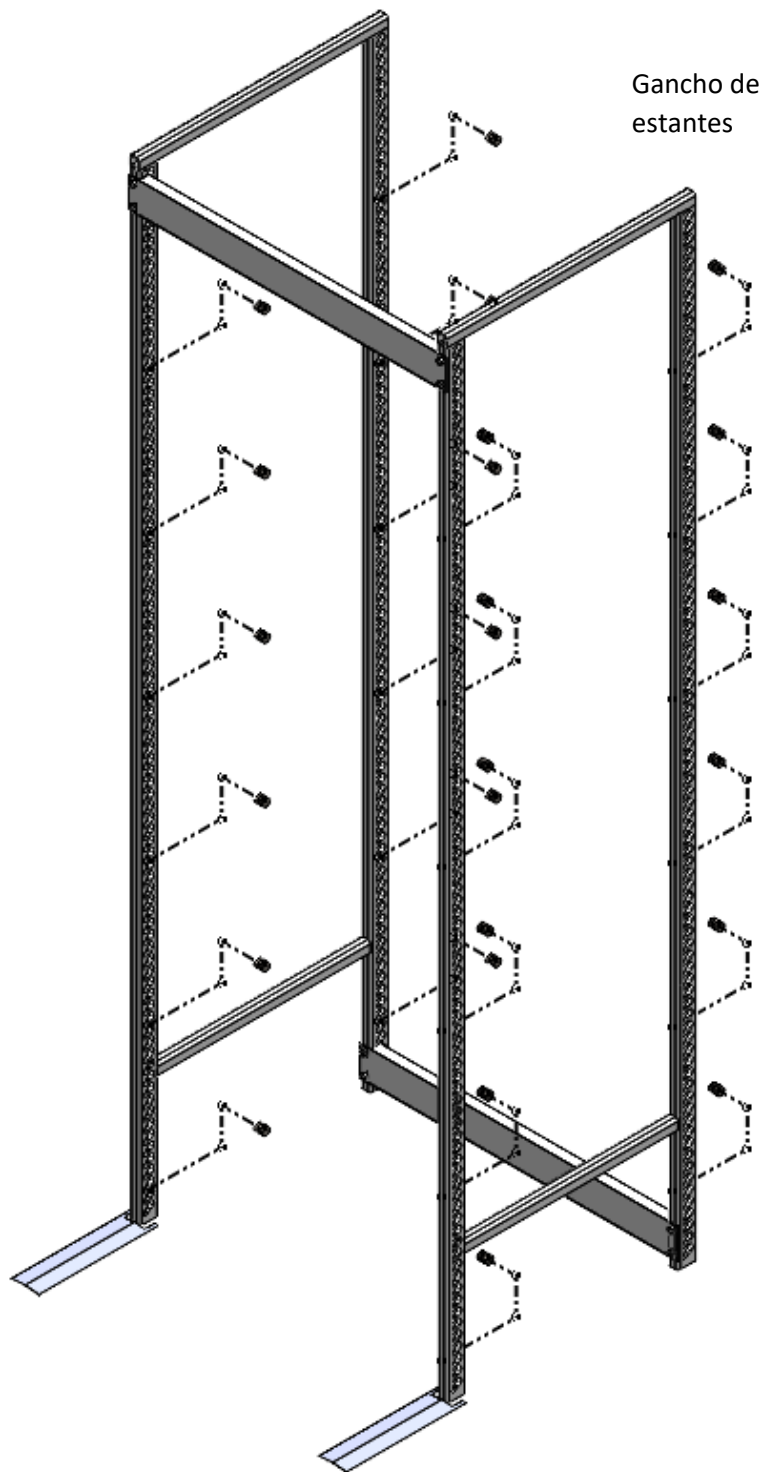

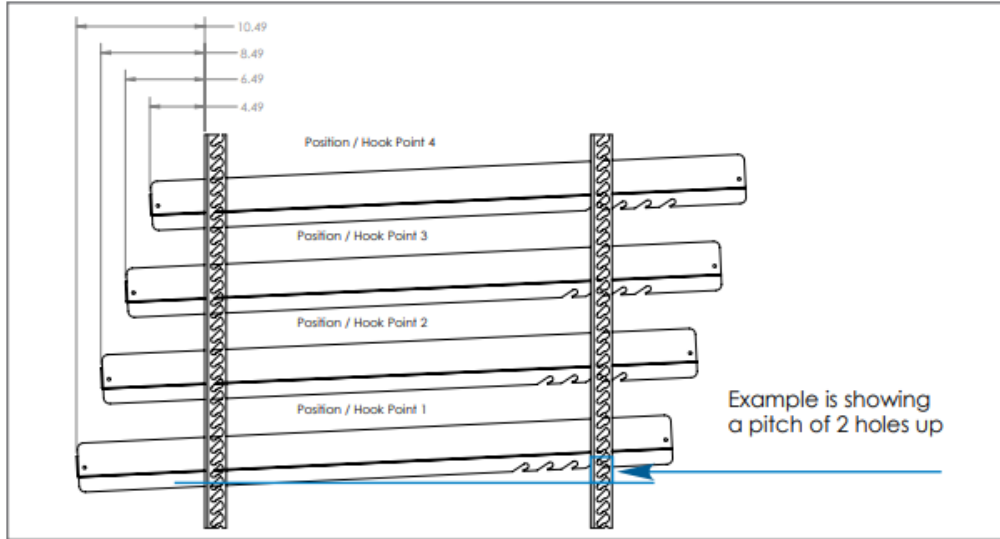

27" Shelf Depth

Product	Number of keyholes notches up
Plastic beverage	3
Carton beer	4
Cardboard water	4
Liquid dairy	3
Liquid dairy	4
Glass packaged	2

36" Shelf Depth

Product	Number of keyholes notches up
Plastic beverage	4
Carton beer	4
Cardboard water	4
Liquid dairy	4
Liquid dairy	4
Glass packaged	2

48" Shelf Depth

Product	Number of keyholes notches up
Plastic beverage	5
Carton beer	5
Cardboard water	5
Liquid dairy	5
Liquid dairy	5
Glass packaged	3

Paso 4: Instale **únicamente** los estantes Superior e Inferior. Use un nivelador para asegurarse que la estructura esté recta.

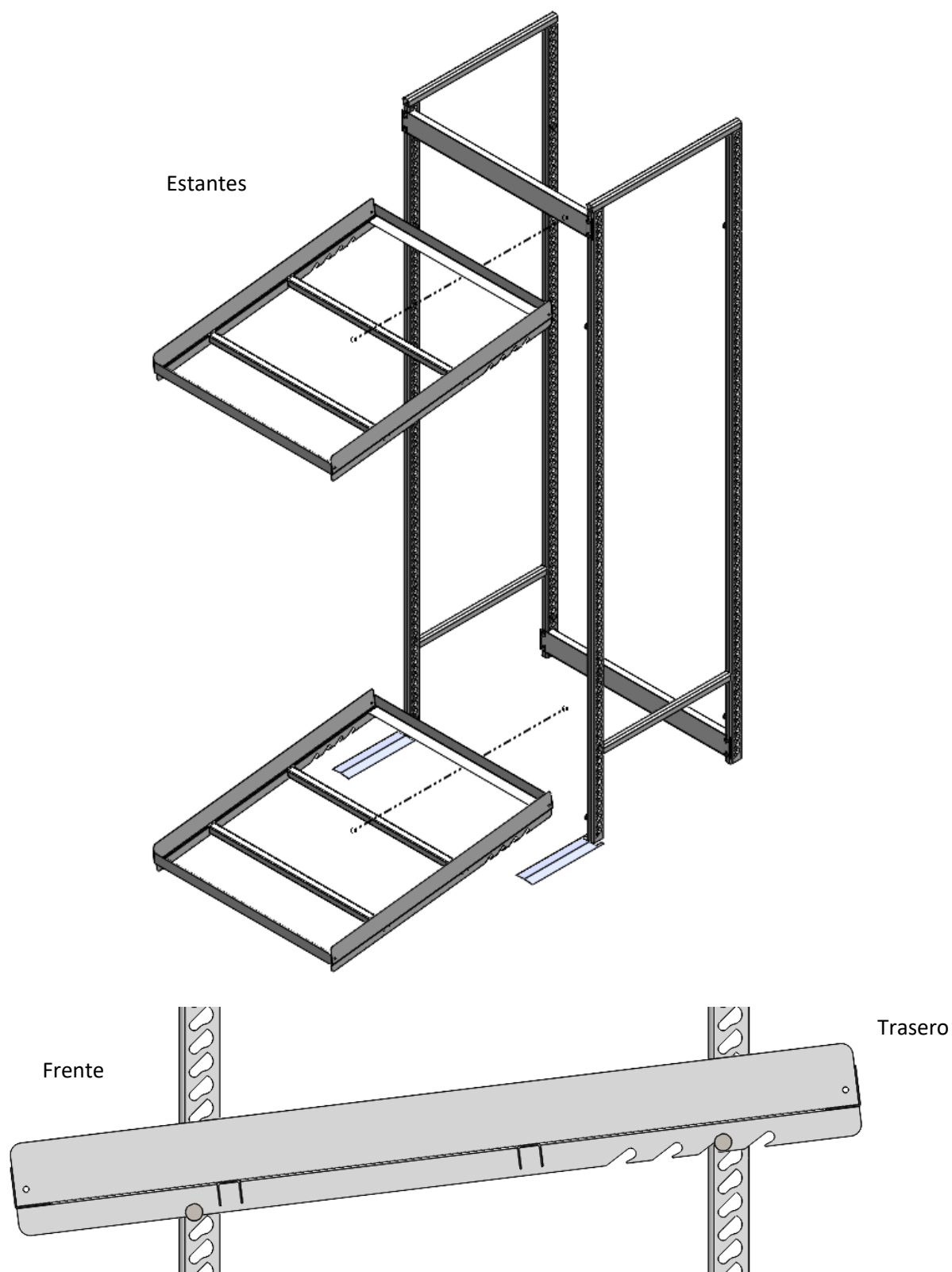

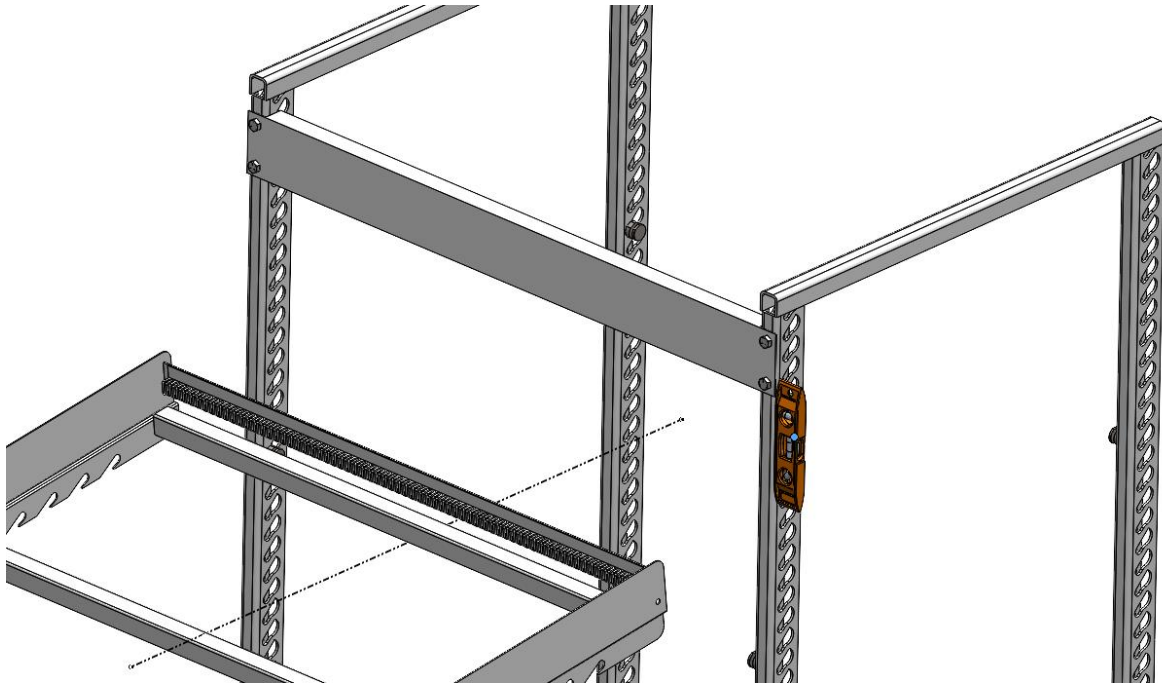

Paso 5: **Apriete** todos los tornillos usando las llaves.

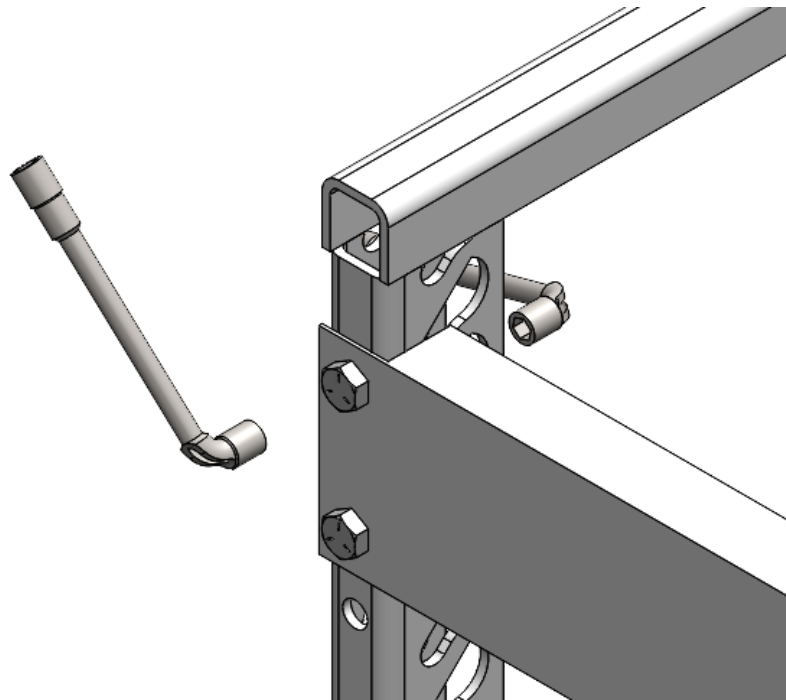

Paso 6: Coloque el resto de los estantes.

Estantes

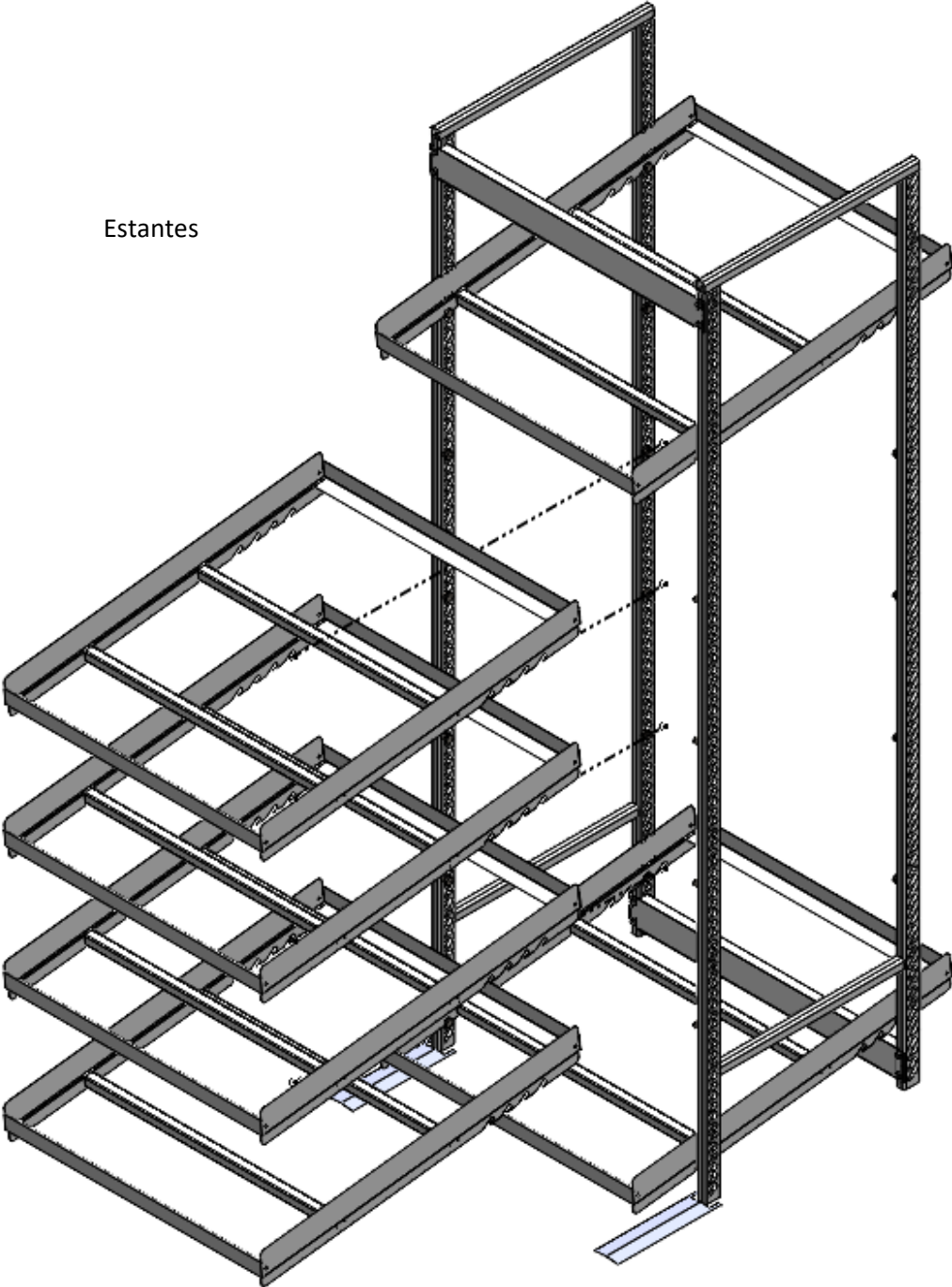

Paso 7: Instale los Moldes de precio frontal y trasero.

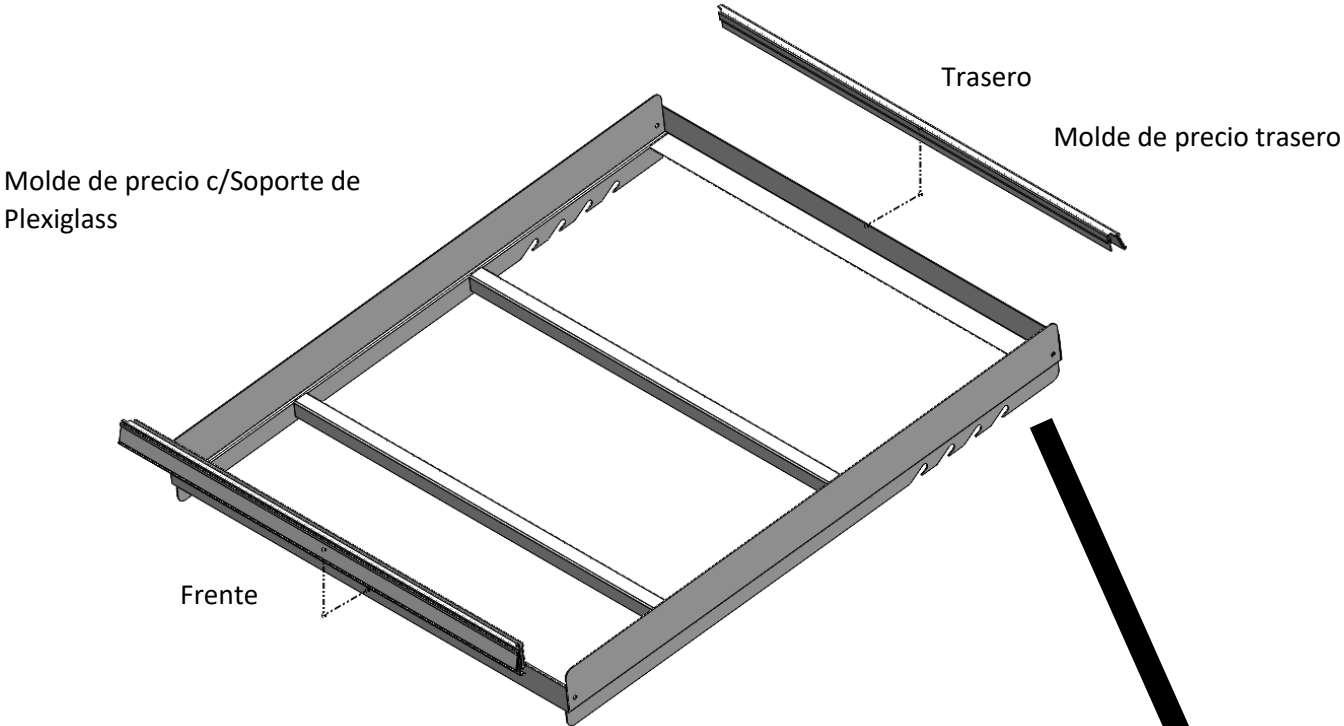

Molde de precio c/Soporte de Plexiglass

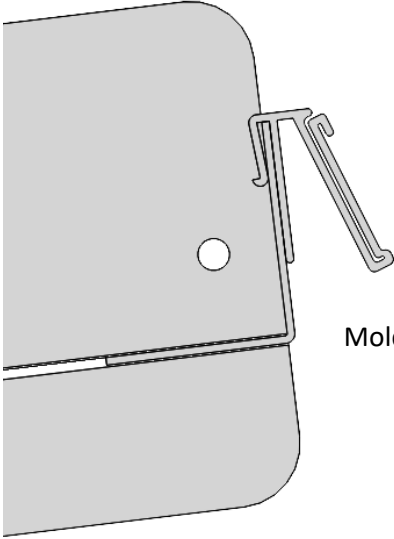
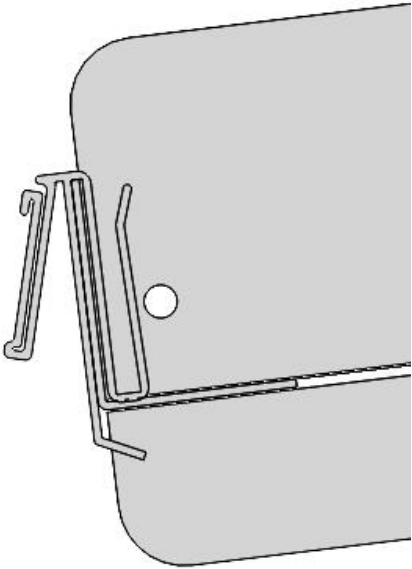

Molde de precio trasero

Paso 8: Coloque las camas de rodillos en los estantes.

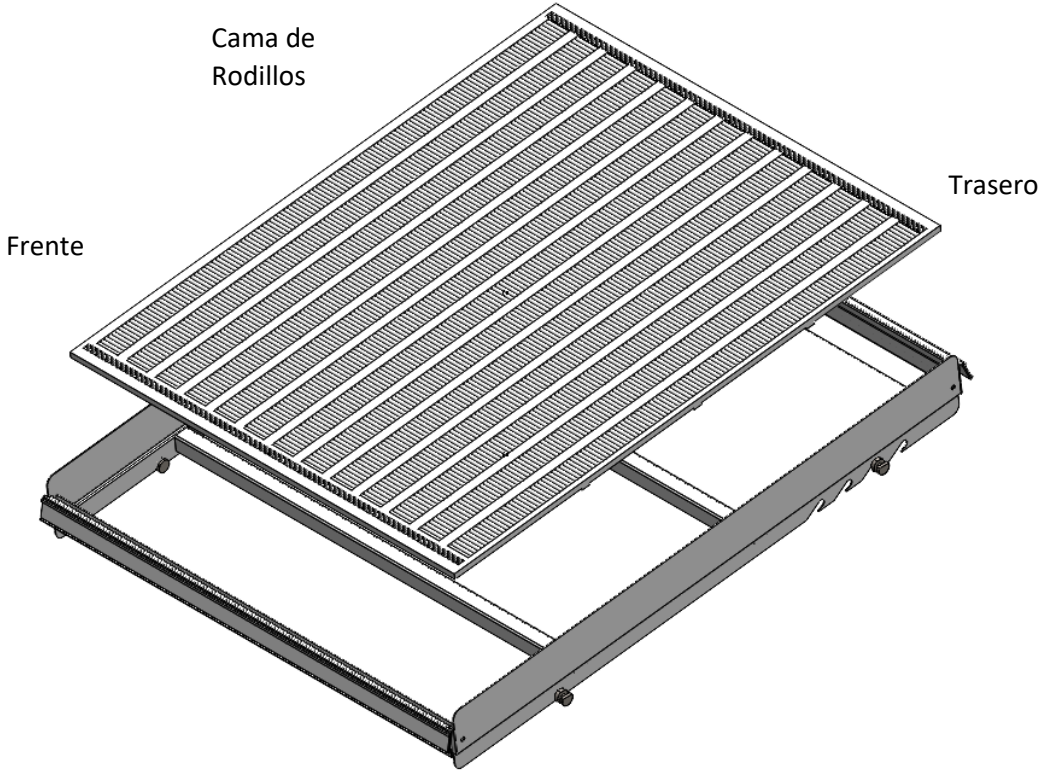

Opcional: En la versión de 4 pies, es requerido instalar tiras de relleno en los lados para asegurar la cama de rodillos.



Paso 9: Instale cuantos divisores internos necesite en base al producto que será mostrado.

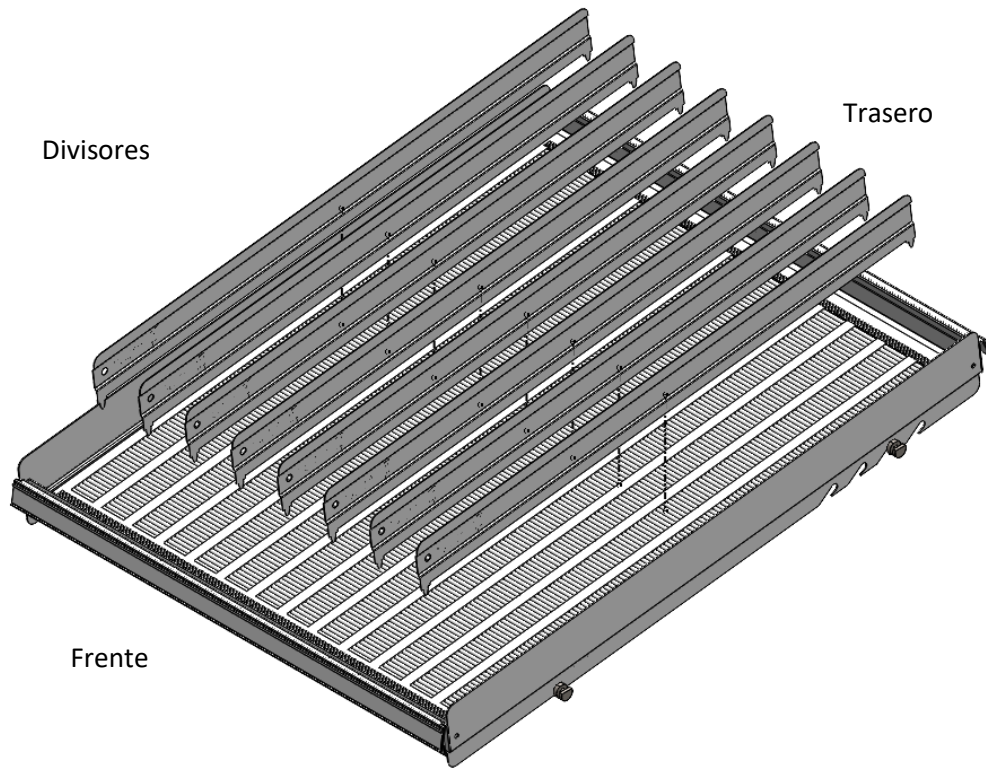

Los divisores deben estar asegurados en las guías, con la parte redonda hacia arriba y debe ir con el mismo lado en cada estante.

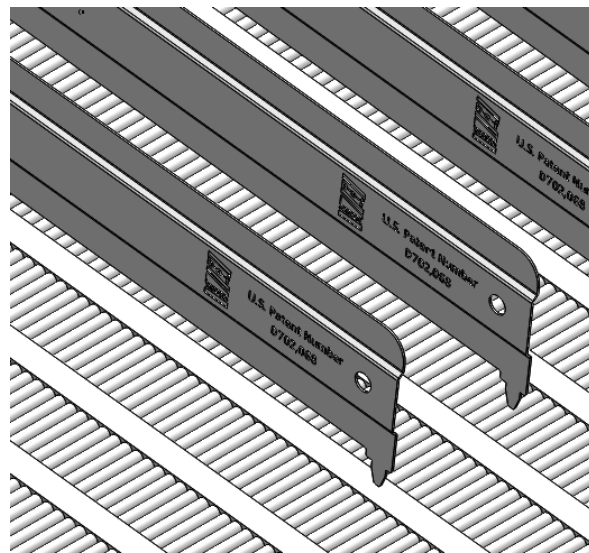

Colocando dos productos en cada línea es una manera útil de colocar los divisores.

Paso 10: Instale los Plexiglass de parada frontal dentro del molde de precio frontal c/Soporte de Plexiglass.

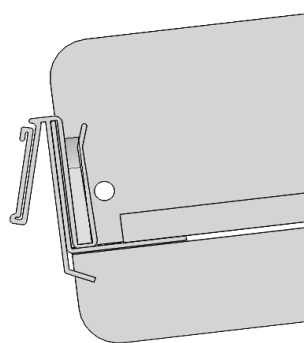
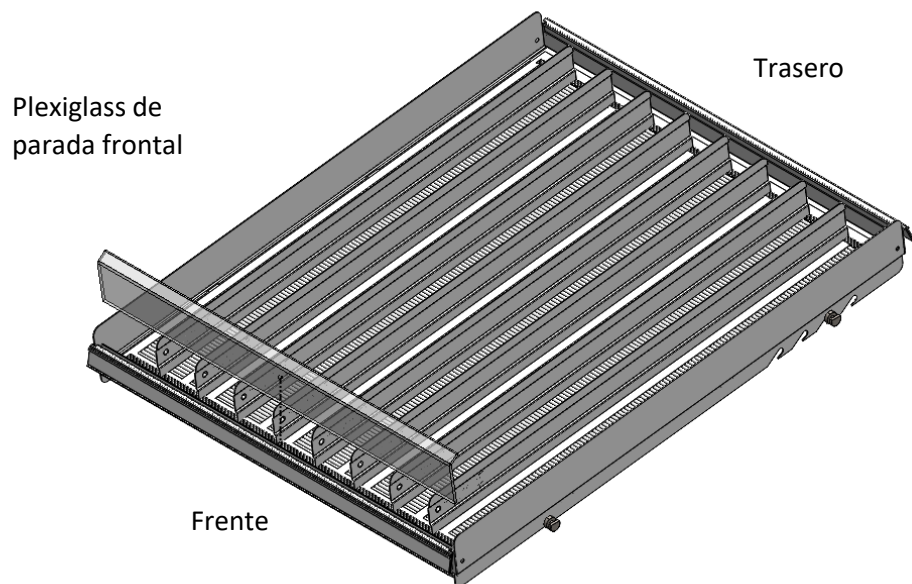

Filler

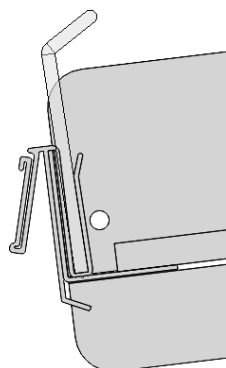

Standard

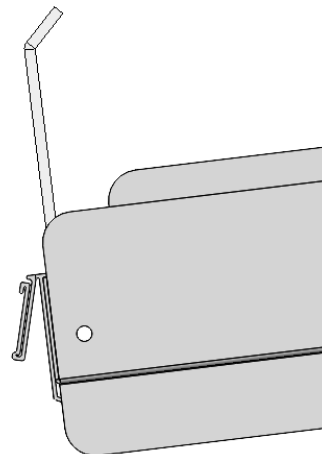

Alto (6 pulgadas)

Ensamblaje Completo:

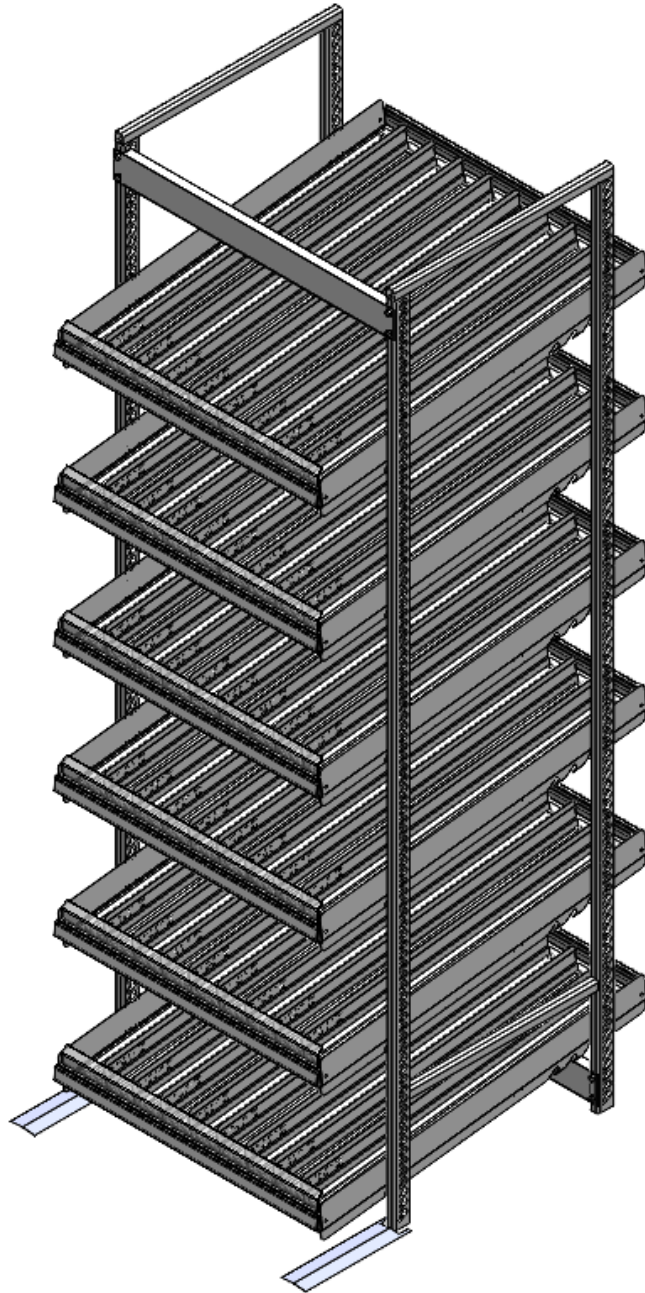

¿Preguntas?

Llame al Servicio al Cliente...800-323-2517