

# VERSARACK + BEER CAVE VR

## ASSEMBLY GUIDE



Intertek

Sanitation Listed  
Certified to NSF/ANSI 2 by Intertek

-Size of parts will differ depending on customer's order.

-Quantity of parts might differ depending on customer's order.

NEED:



Two people  
needed



1/2" Wrench & Ratchet with  
1/2" Deep Well Socket



Level



Utility  
Gloves

PARTS LIST

(Upright)

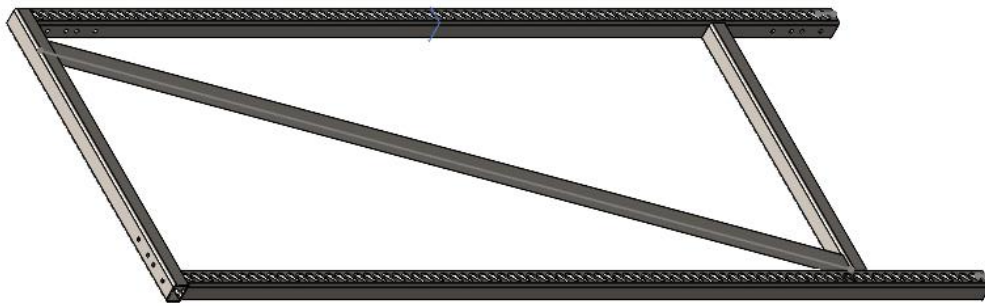

(Sway Braces – two (2) x 3" Sway brace per section is required)

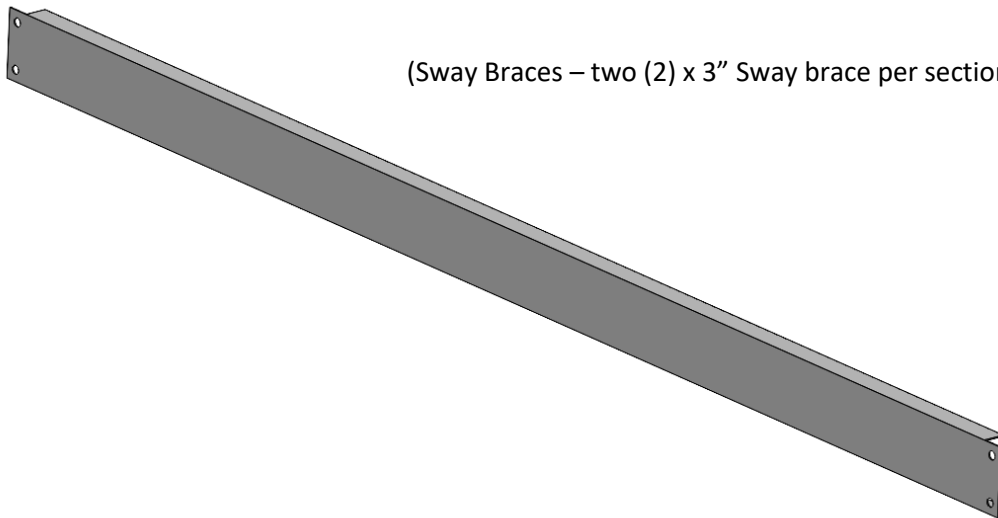

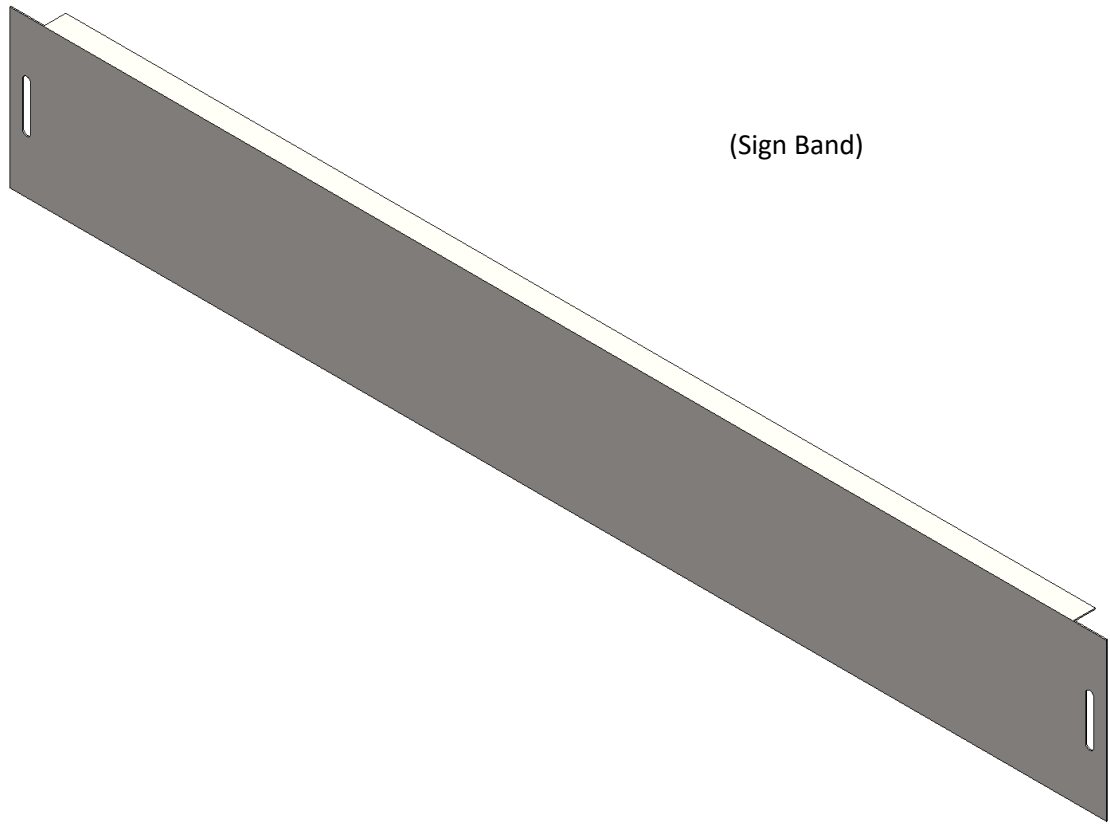

(Sign Band)

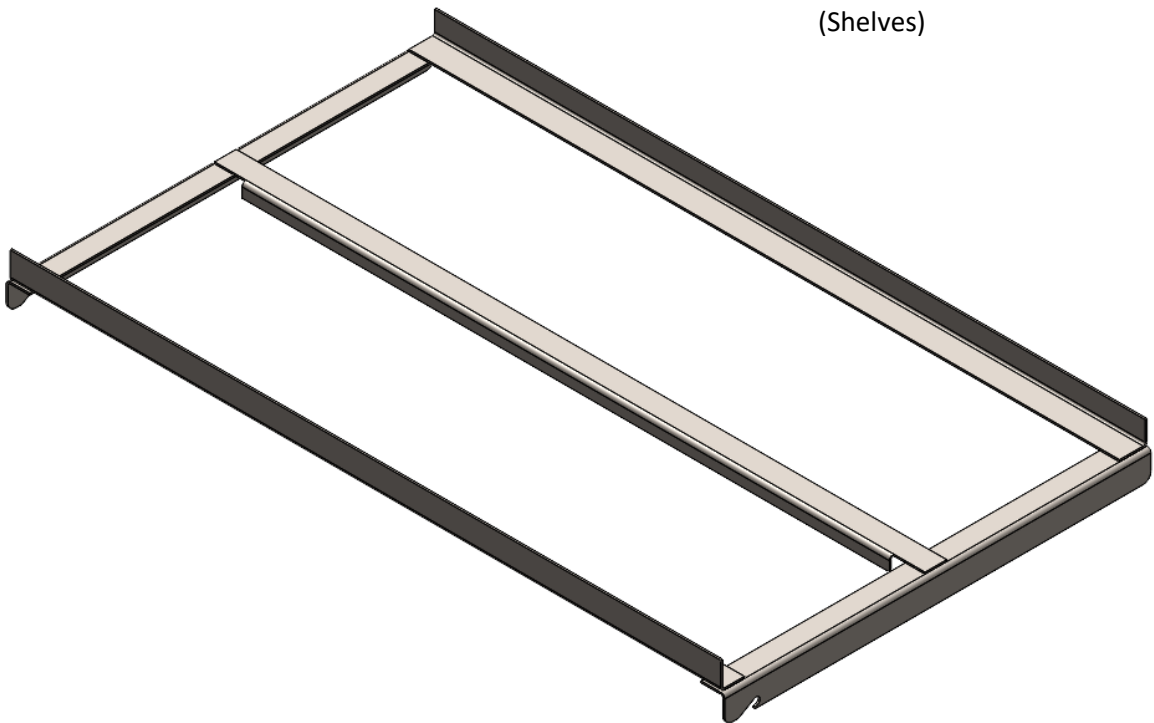

(Shelves)

(Roller Mat)

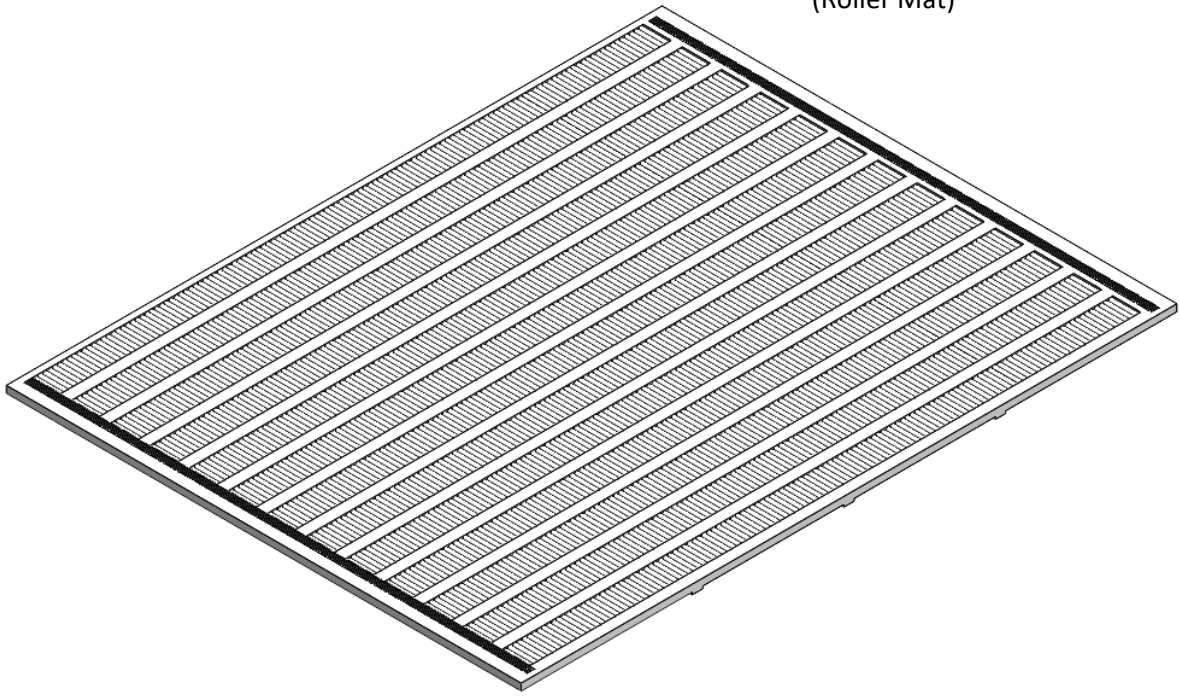

(Side Product Stops)

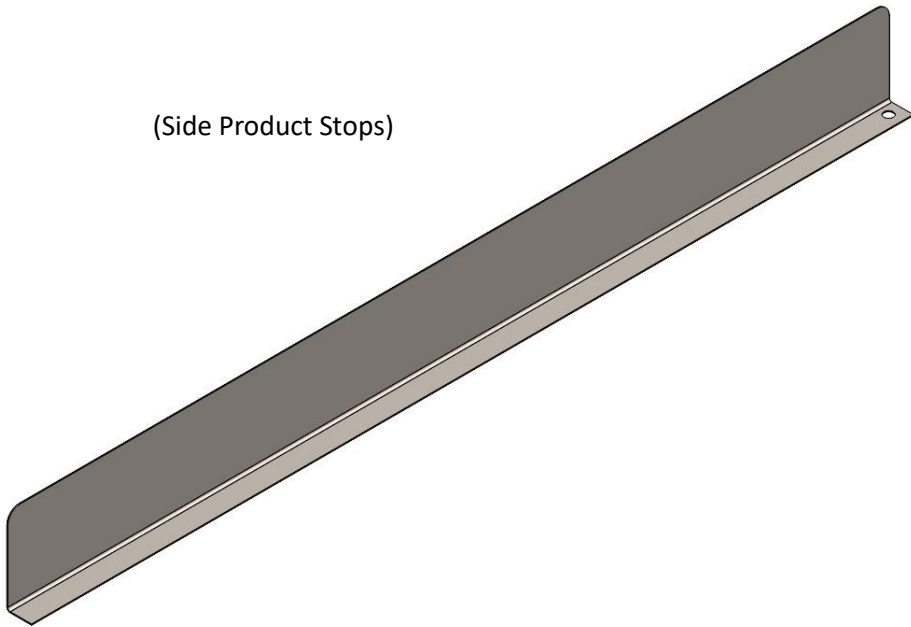

(Inner/ Lane Dividers)

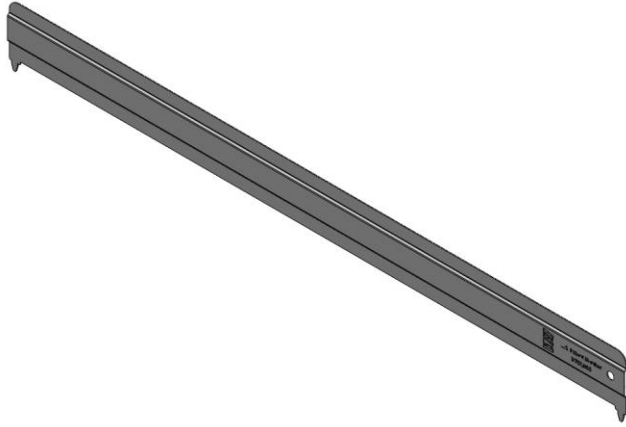

Rounded Side Up

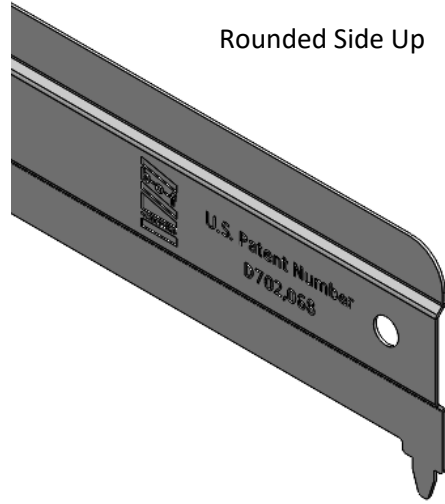

(Front Price Tag Molding)

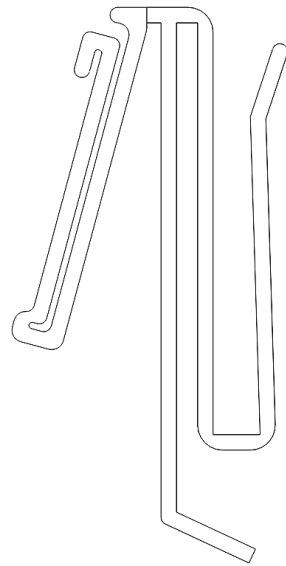

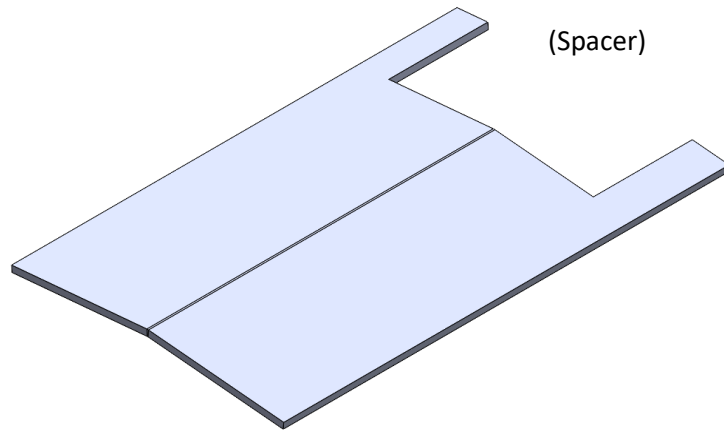

(Spacer)



Shelf Clamps

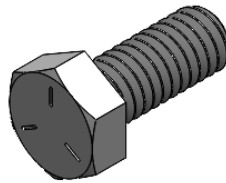

5/16" Bolt

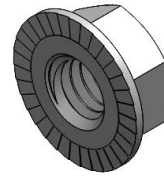

5/16" Wiz Nut

**Step 1: Tighten with fingers**, leave just finger tight until the end. Do **NOT** tighten with wrench until the end. Suggested location of sway braces are Bottom Front & Bottom Back. **2 x 3" Sway brace & 1 Sign banner on the front per section.**

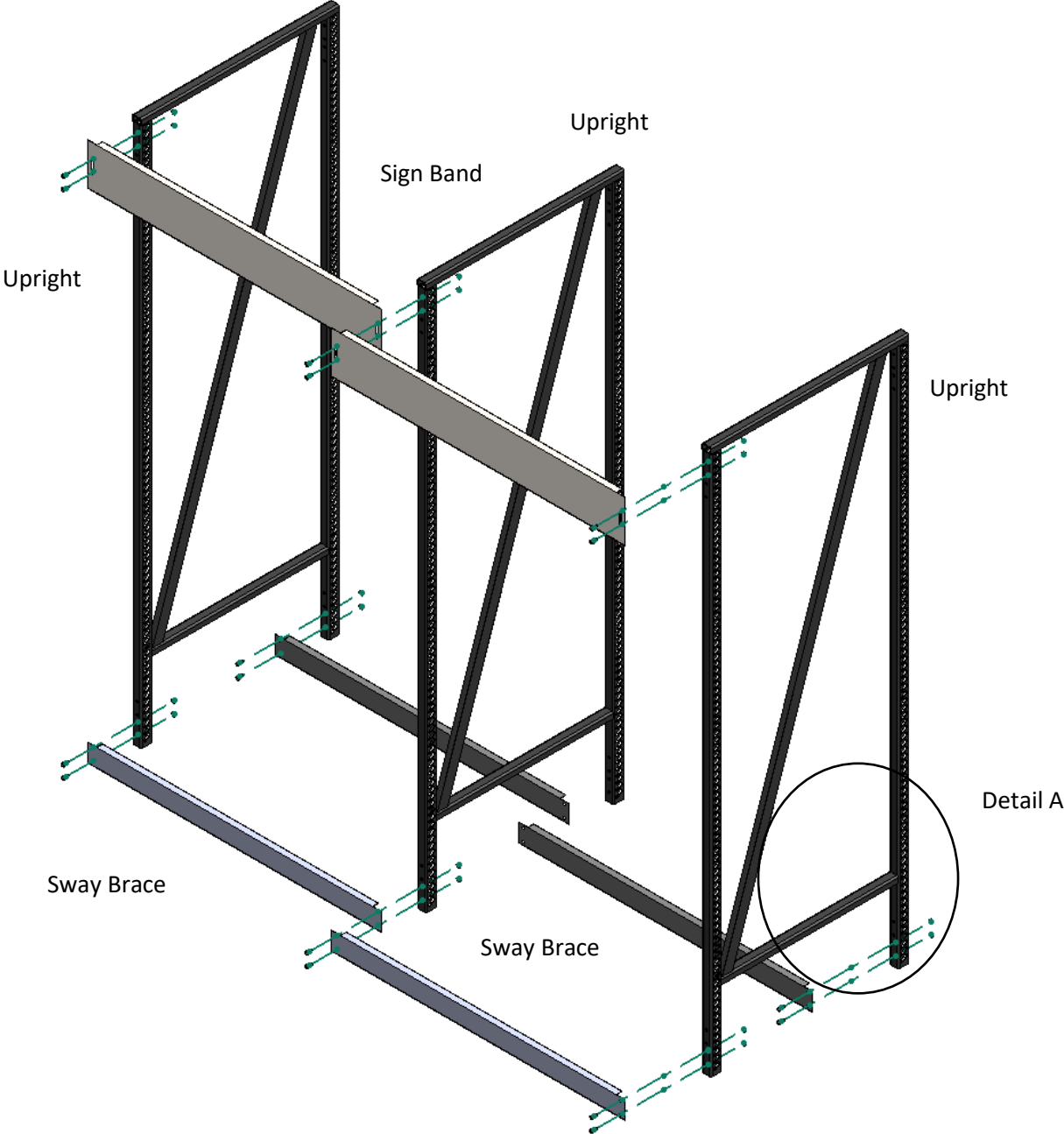

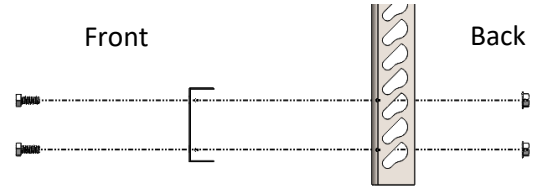
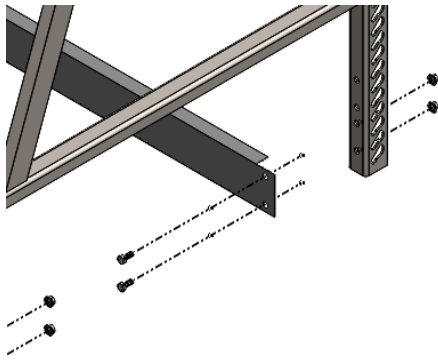

Detail A

(On the upcoming steps, Sign Brace will be hidden to make it easier to see the assembly process)

**Step 2:** Use spacers to set the clearance from the Frame to the wall.

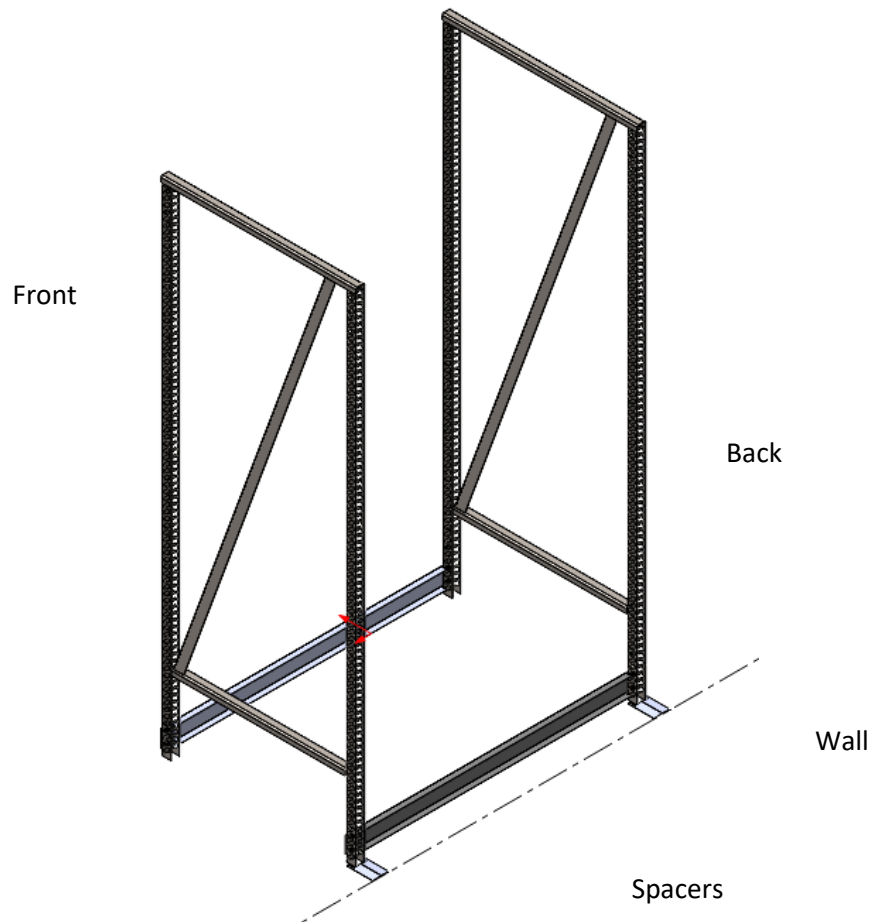



**Step 3:** Set Shelf clamps on the Upright frame to attach the Shelves.



Depth	Notches Separation
27"	3
36"	4
48"	5

**Step 4:** Install top and bottom shelf frames **ONLY**. Use level to make sure rack is plumb.

Shelf Frames

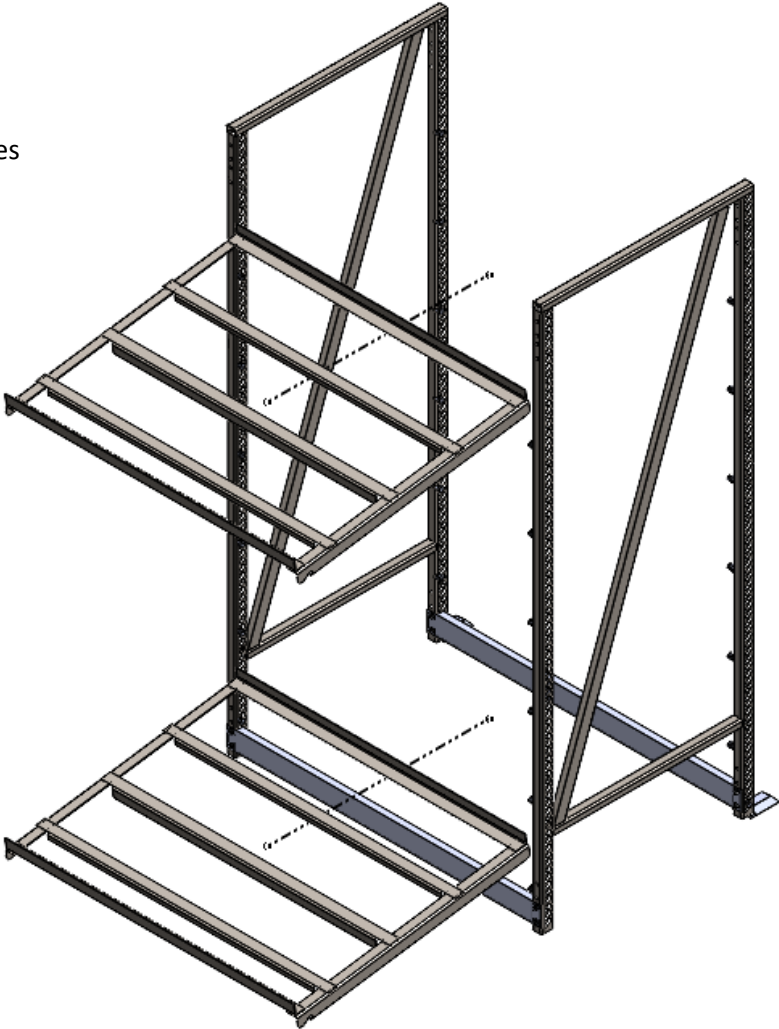

Front

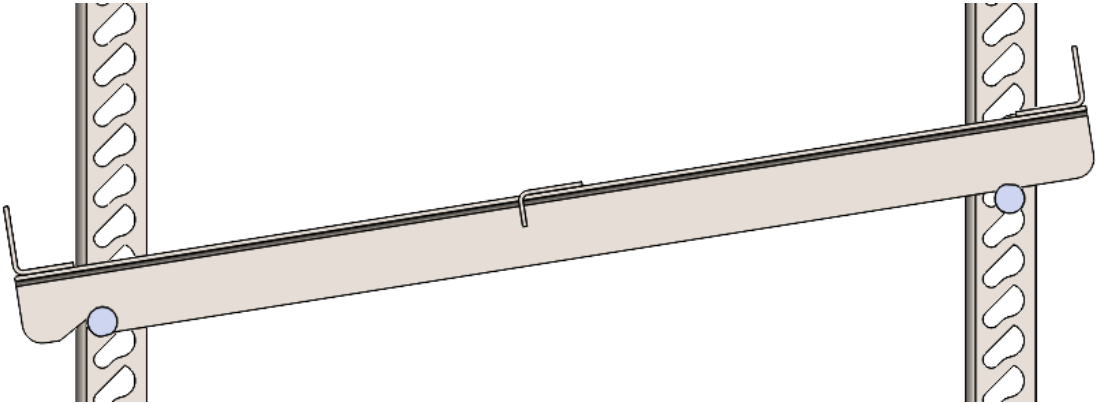

Back

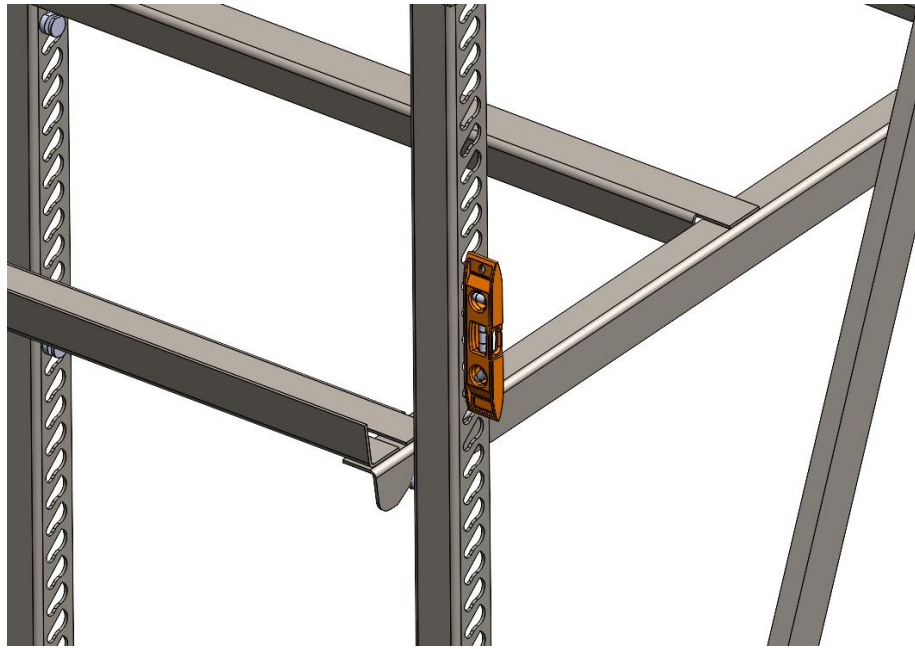

Step 5: **Tighten** all the bolts and nuts using the wrenches.

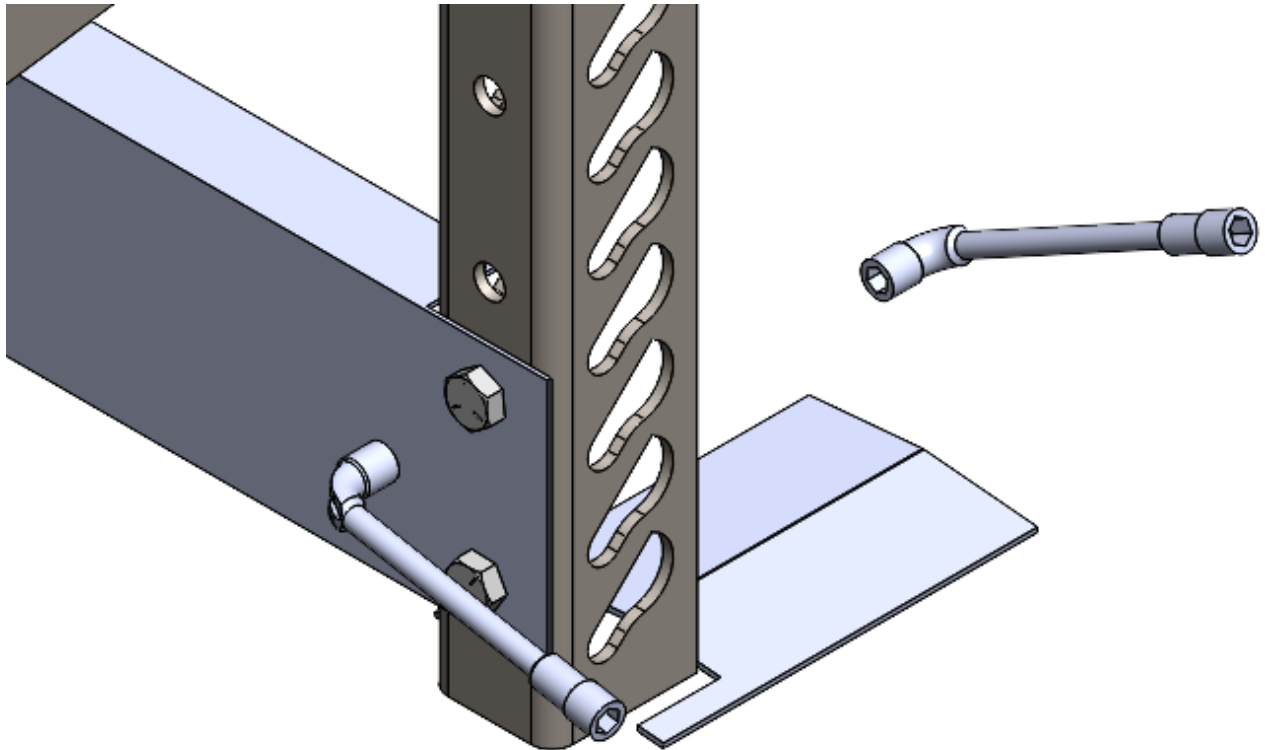

**Step 6:** Install remaining Shelf Frames.

Shelf Frames

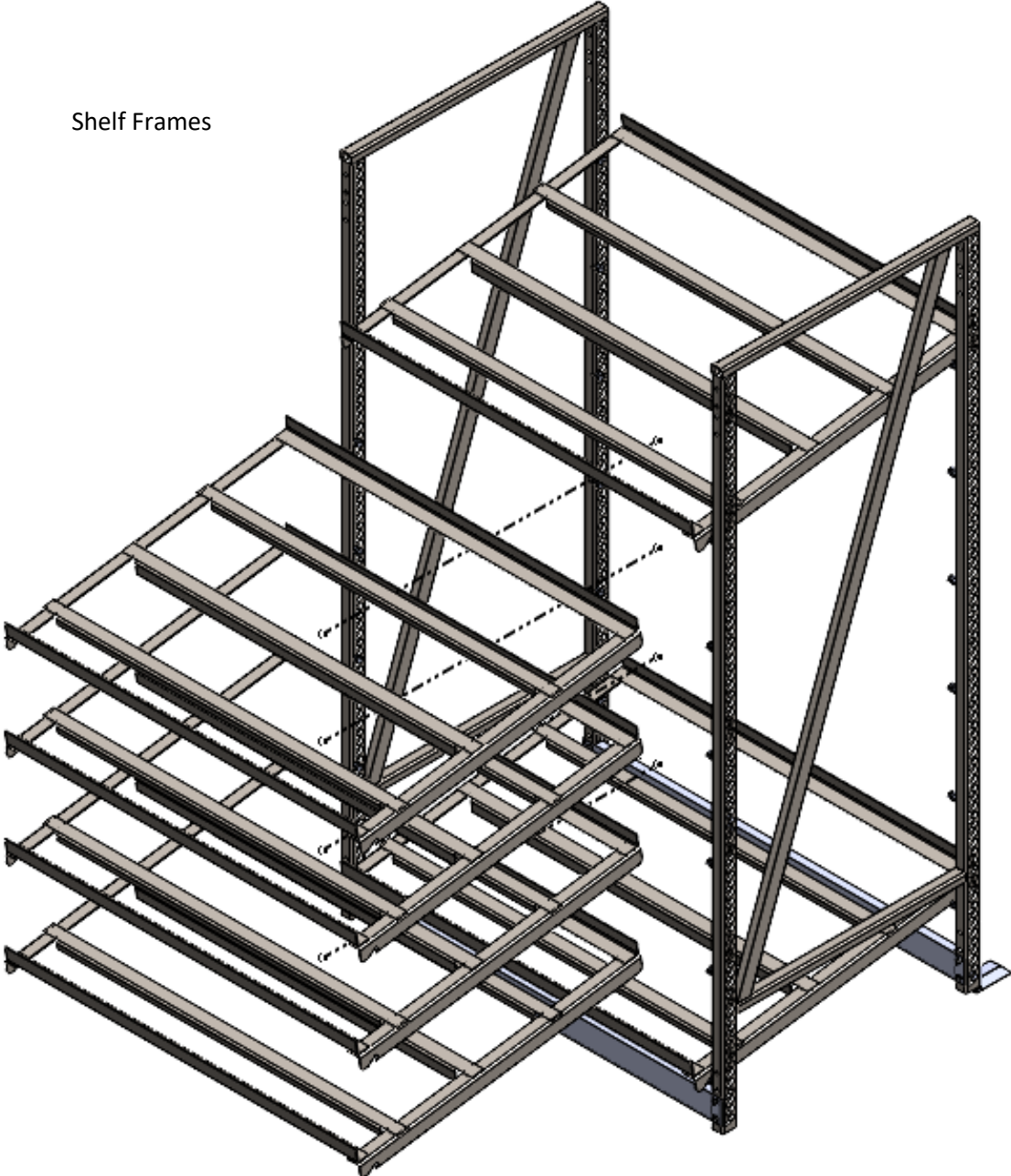

**Step 7:** Install Front Tag Molding & Side Product Stops.

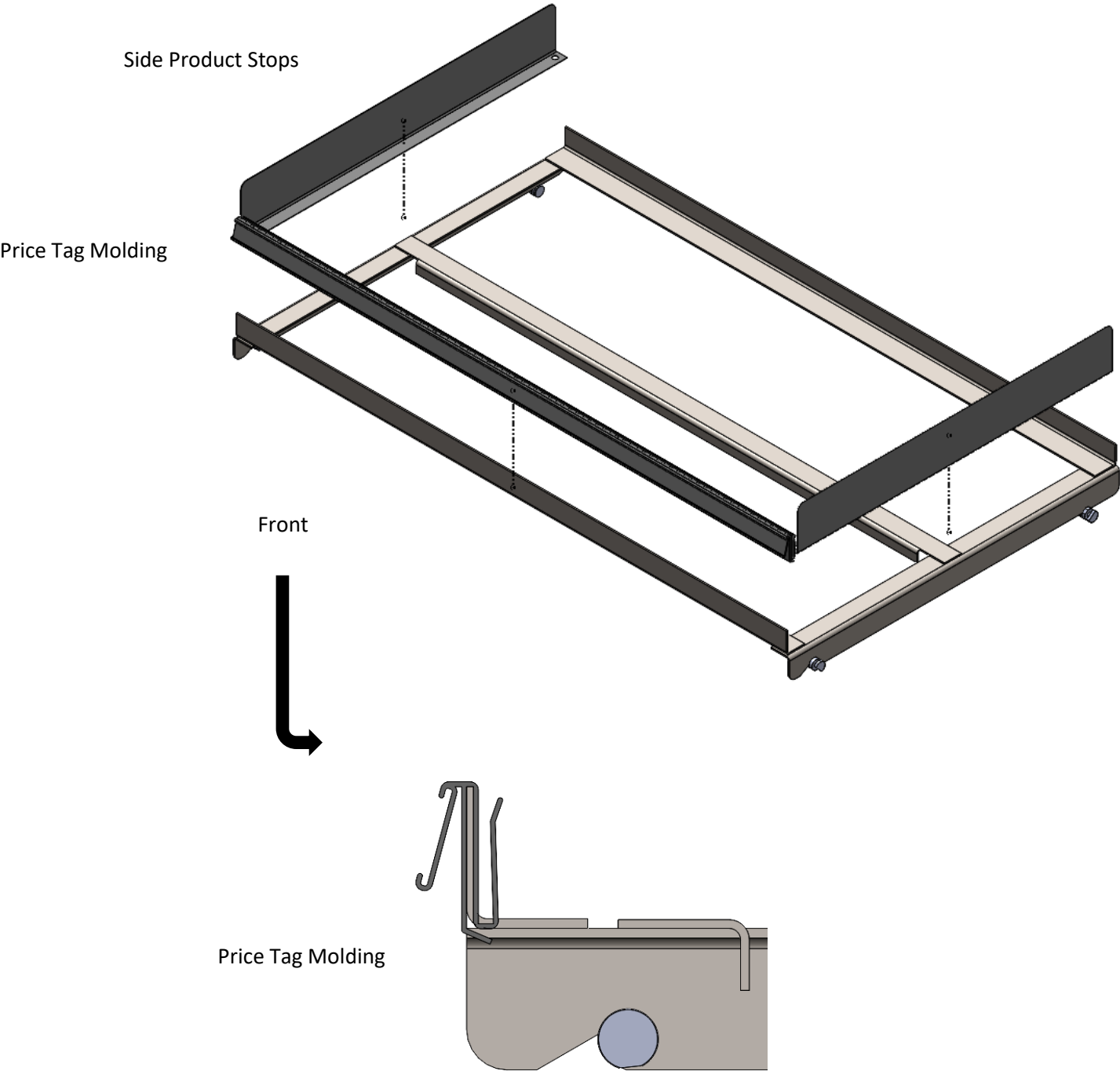

**Step 8:** Set the Roller mats on the Side Product Stops.

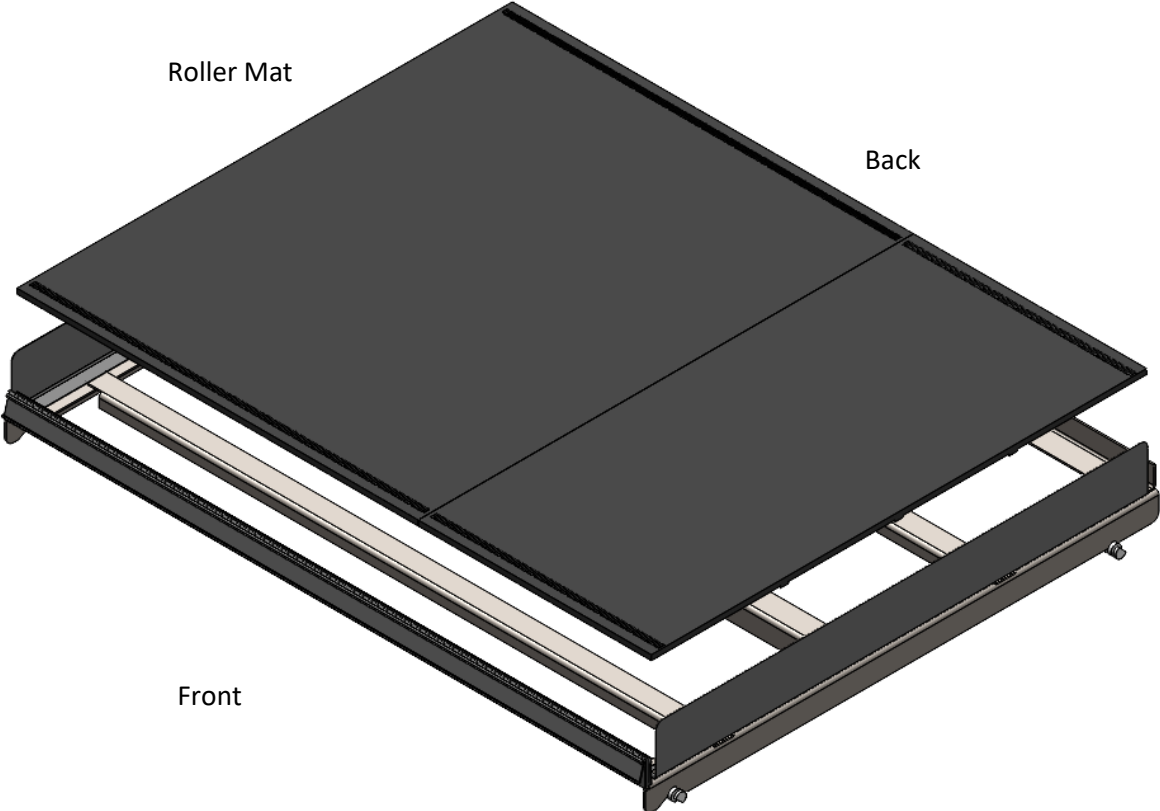

**Step 9:** Install Lane dividers as needed based upon product displayed.

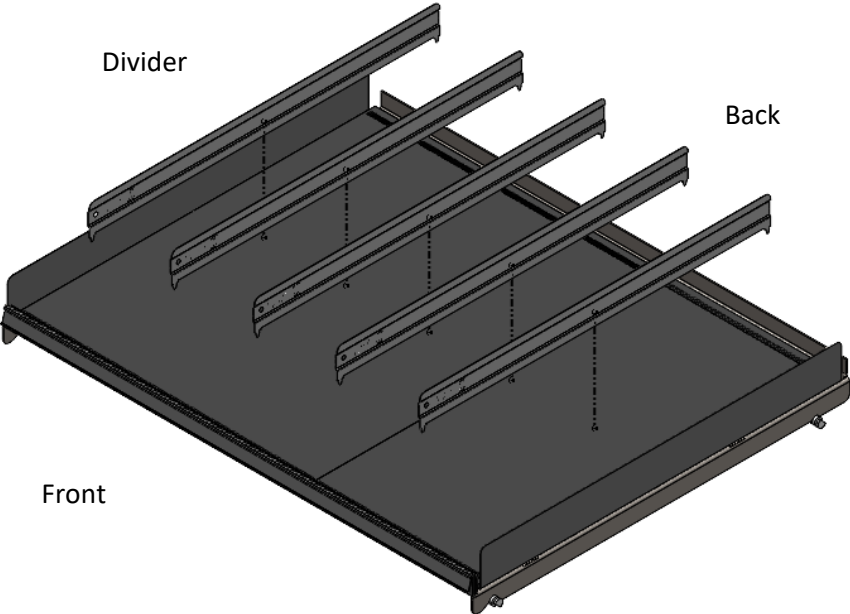

Dividers to be secure in the slots, round side must be up and all indents must go the same way in each shelf

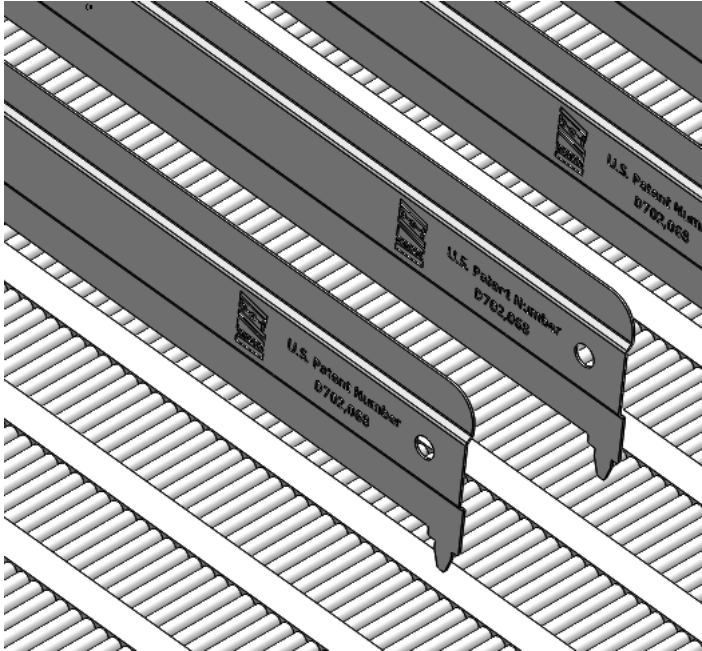

Laying two products down in each lane is a helpful way to set lane dividers.



**Completed Assembly:**



**Questions?**

**Call Customer Service...800-323-2517**