

VERSAWINE SHELVES

ASSEMBLY GUIDE



Intertek

Sanitation Listed
Certified to NSF/ANSI 2 by Intertek

-Size of parts will differ depending on customer's order.

-Quantity of parts might differ depending on customer's order.

NEED:



Two people
needed



Utility
Gloves

PARTS LIST

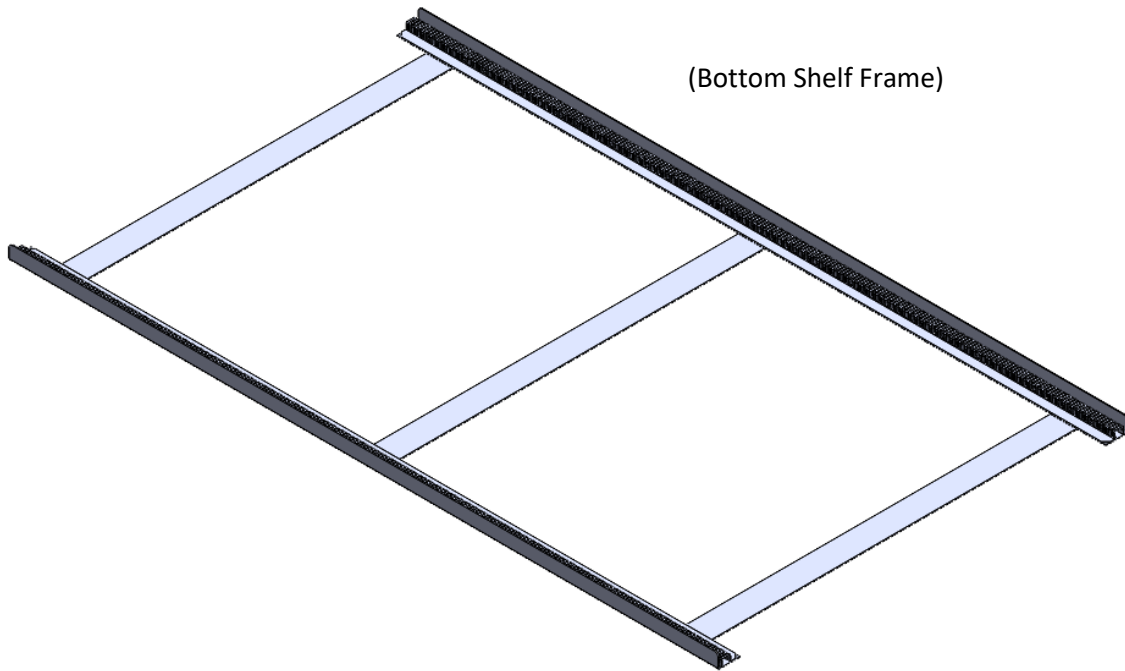

(Bottom Shelf Frame)

(Upper Shelf Frame)

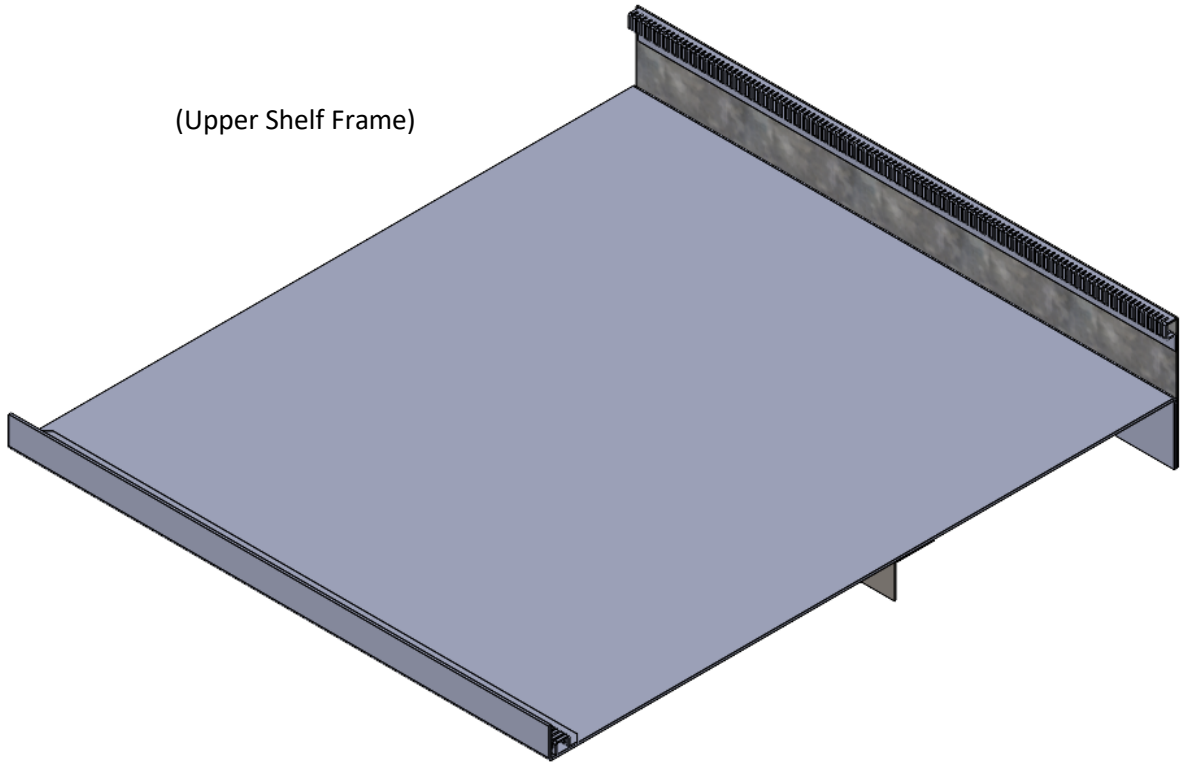

(Glide Sheet)

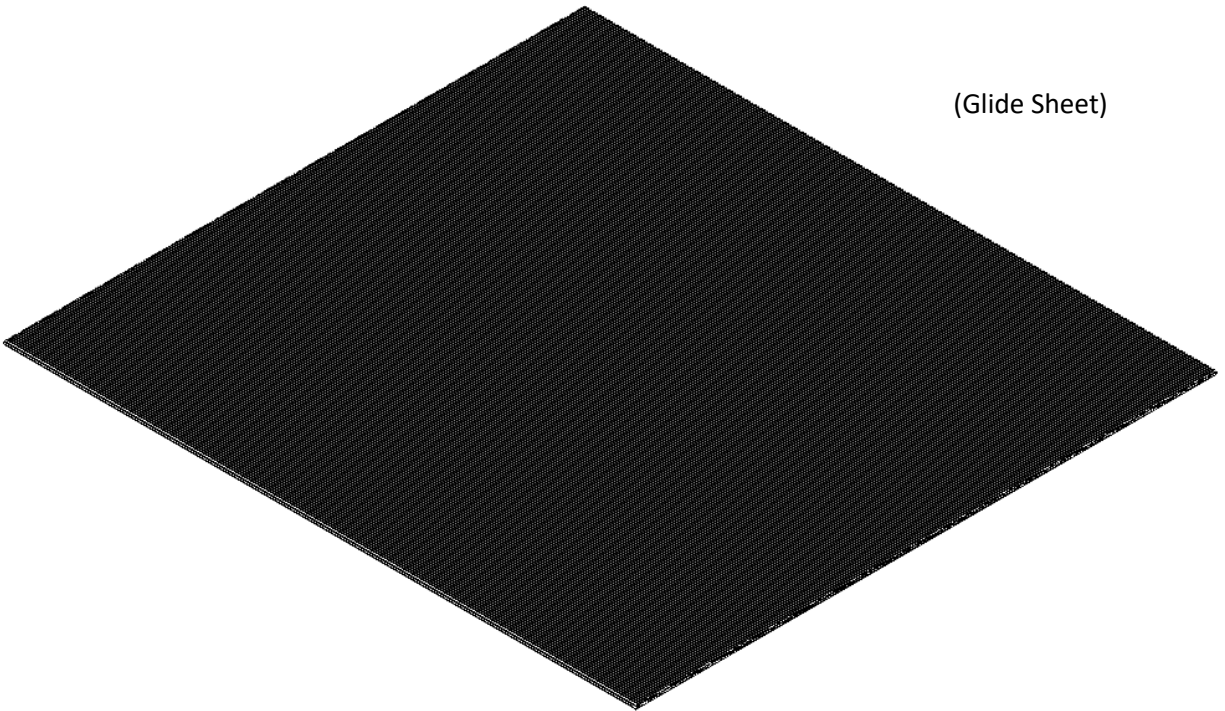

(Inner/ Lane Dividers)

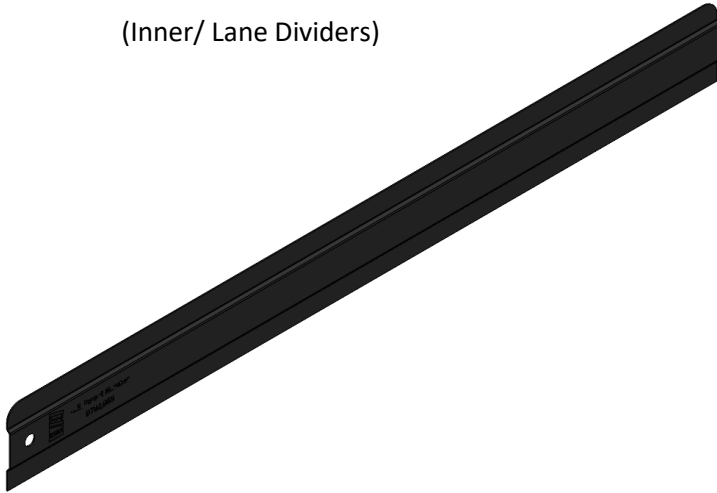

Rounded Side Up

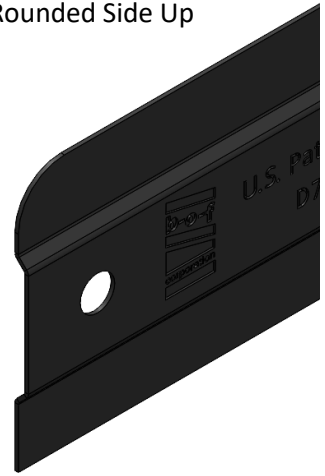

(Plexiglass Front Product Stop)

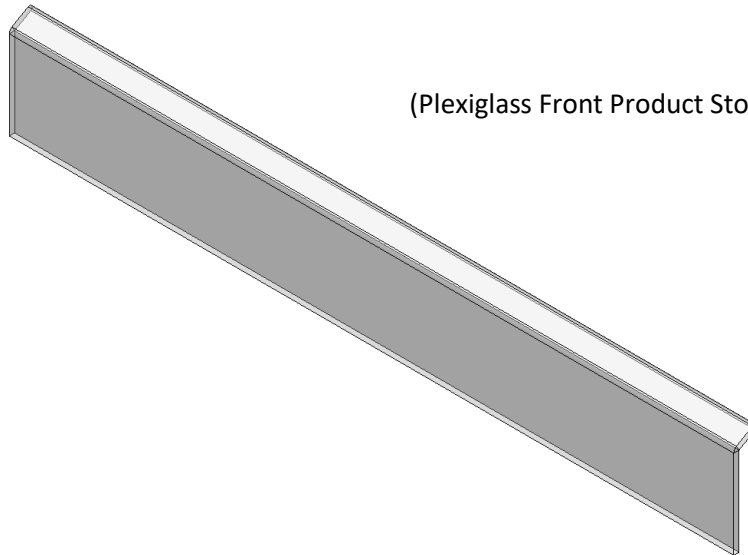

BOTTOM SHELF ASSEMBLY

Step 1: Set the Bottom Shelf Frame in the existing wine shelf, then set the glide sheets on top of the shelf frame.

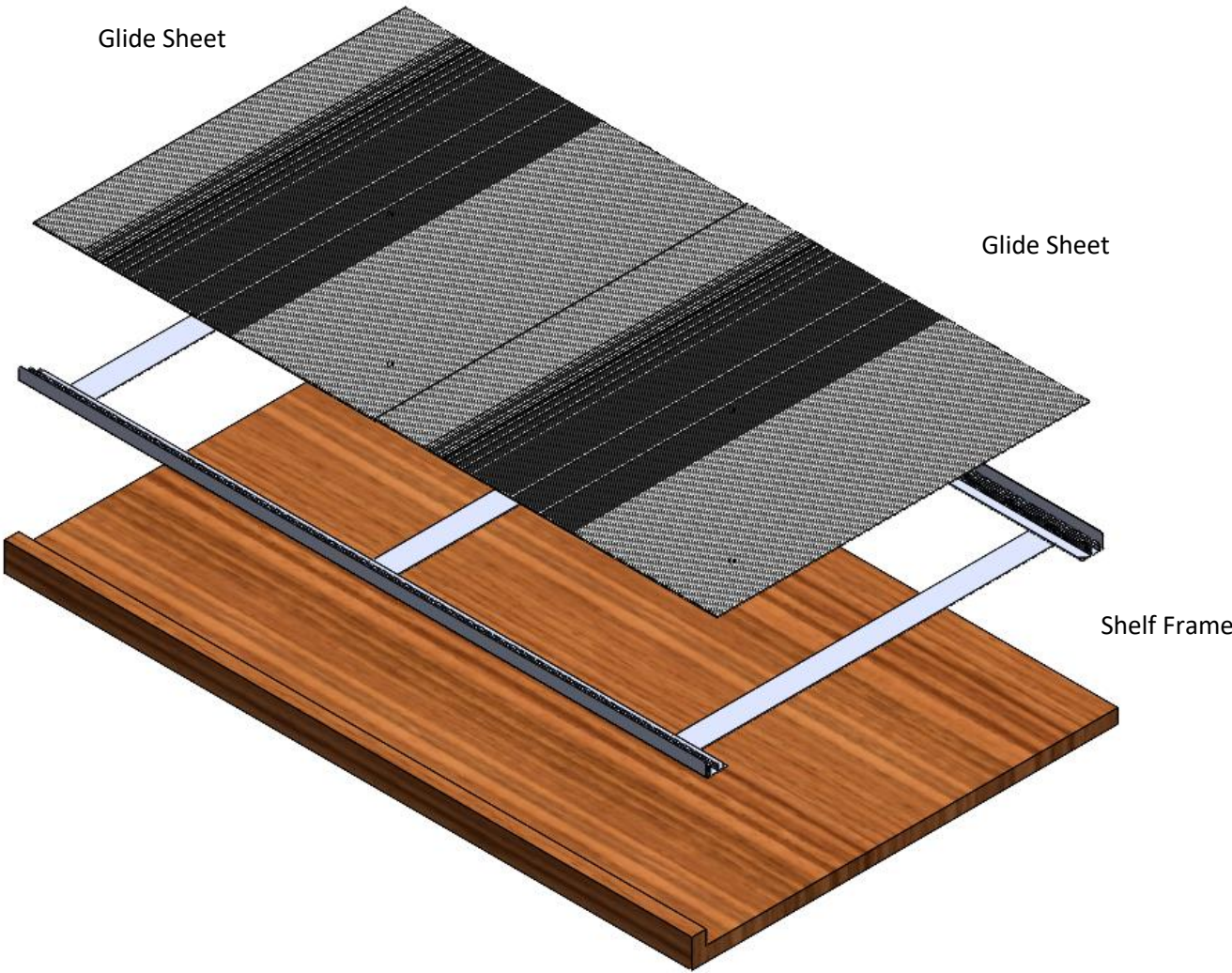

Step 2: Install Lane dividers as needed based upon product displayed.

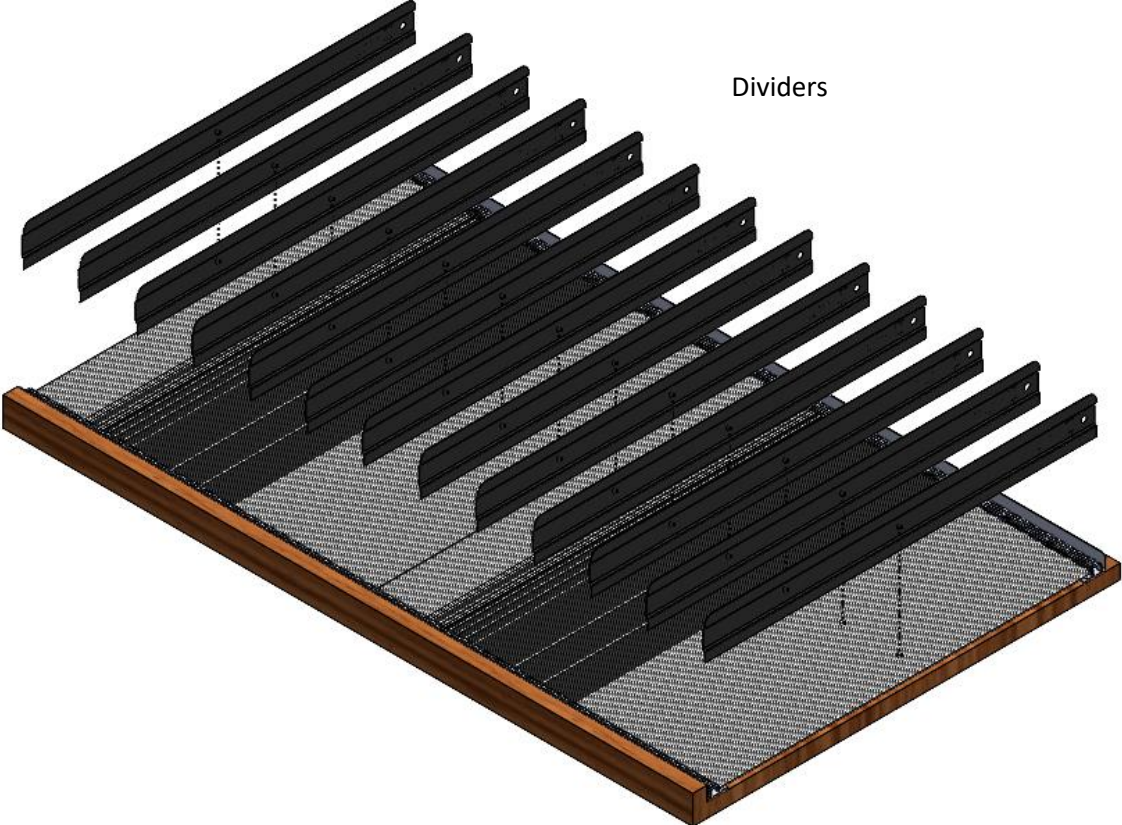

Dividers to be secure in the slots, round side must be up and all indents must go the same way in each shelf

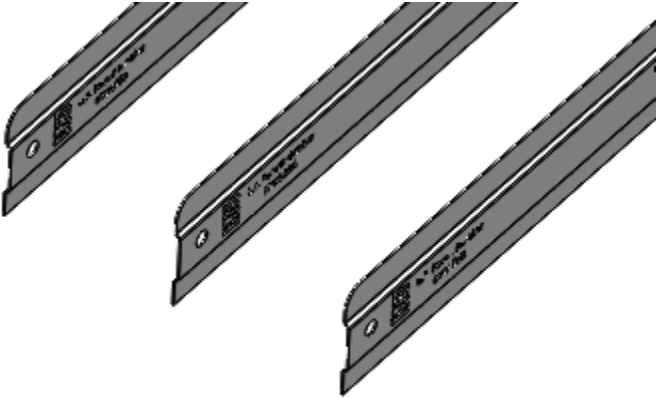

Laying two products down in each lane is a helpful way to set lane dividers.

Step 3: Install Plexiglass front product stop into the Plexi Holder slots.

Plexiglass Front
Product Stop

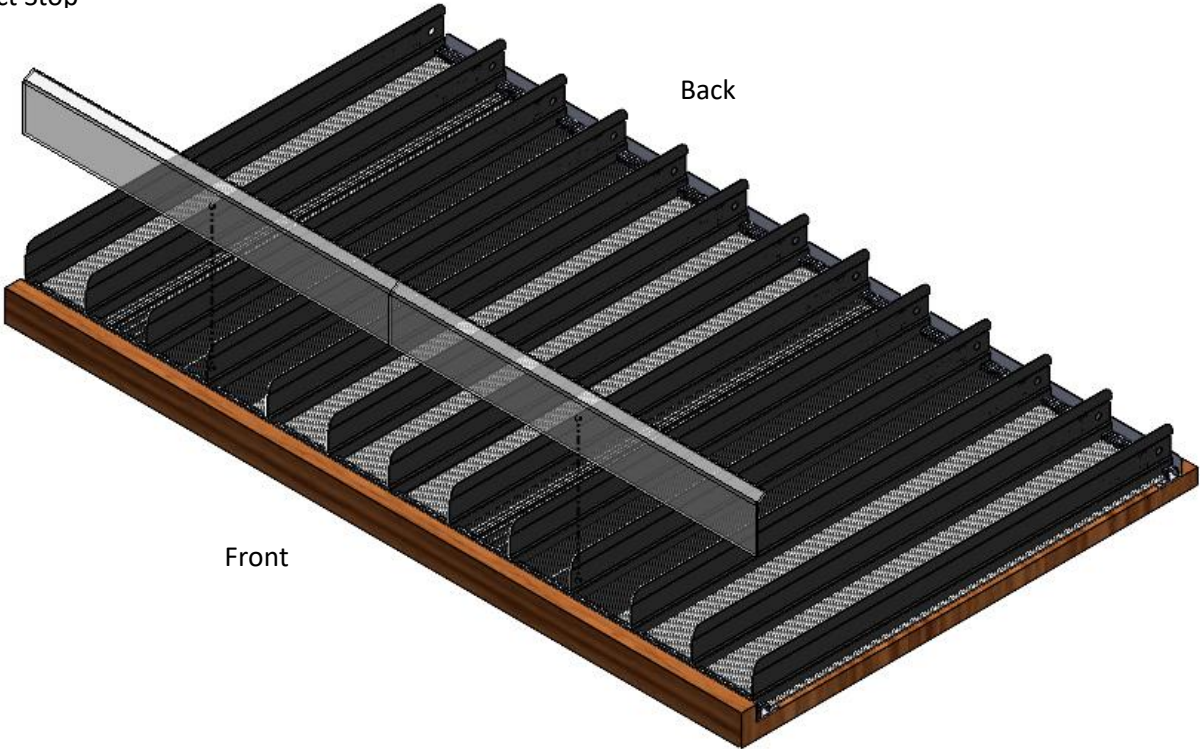

Completed Assembly:

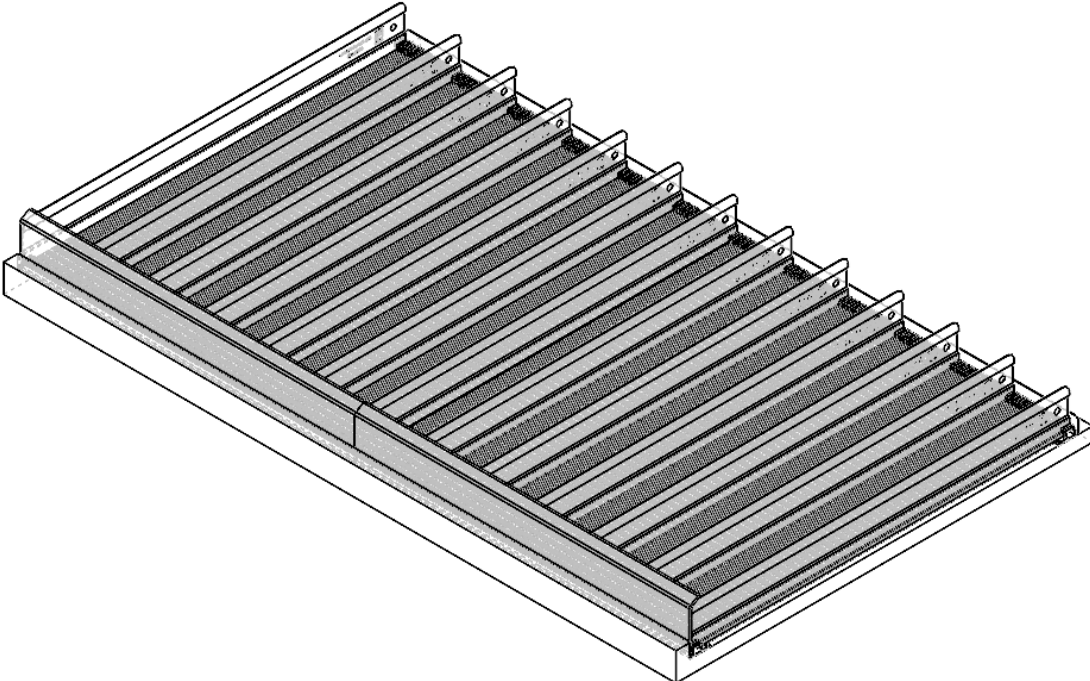

UPPER SHELF ASSEMBLY

Step 1: Set the Upper Shelf Frame in the existing wine shelf, then set the glide sheets on top of the shelf frame.

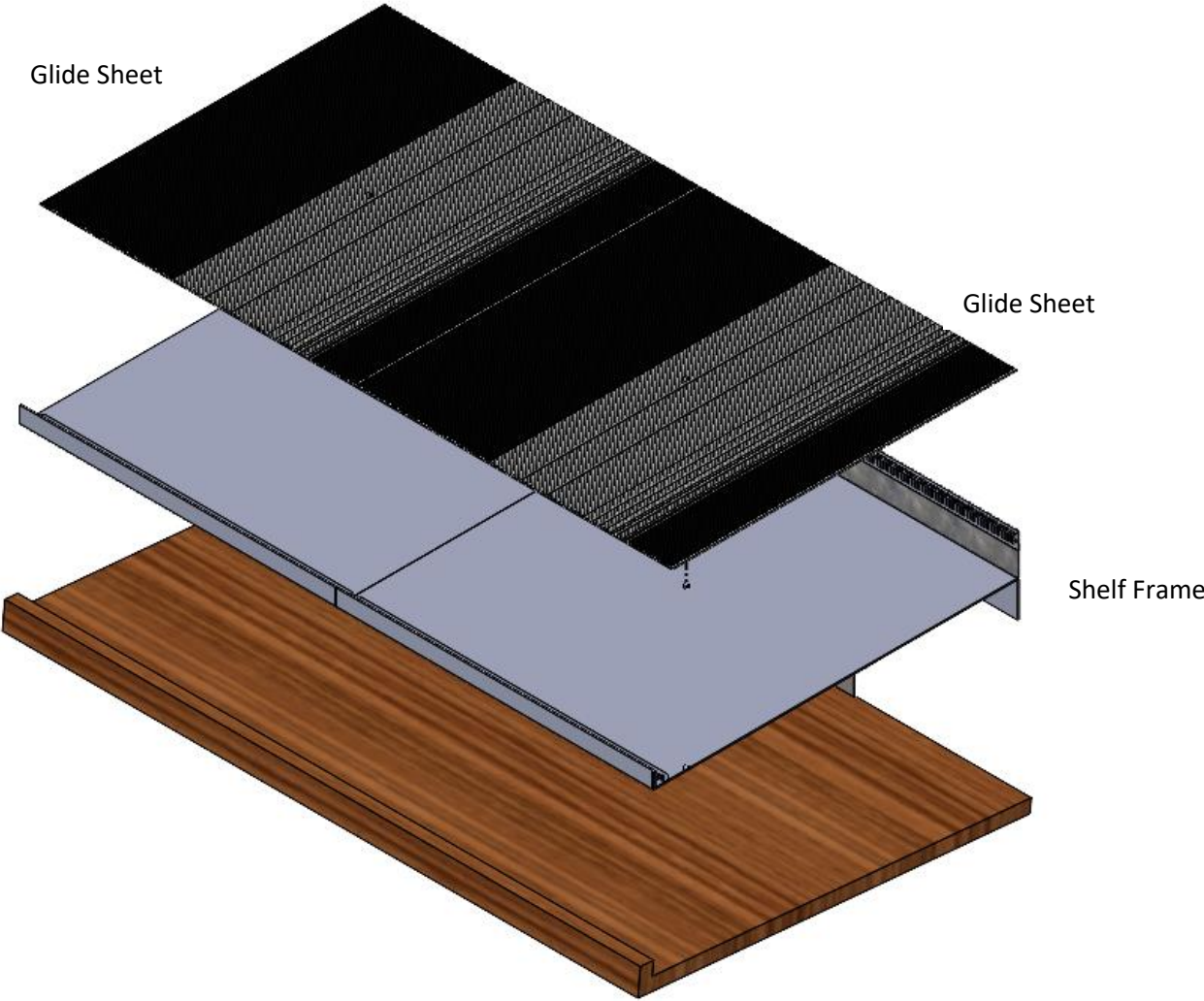

Step 2: Install Lane dividers as needed based upon product displayed.

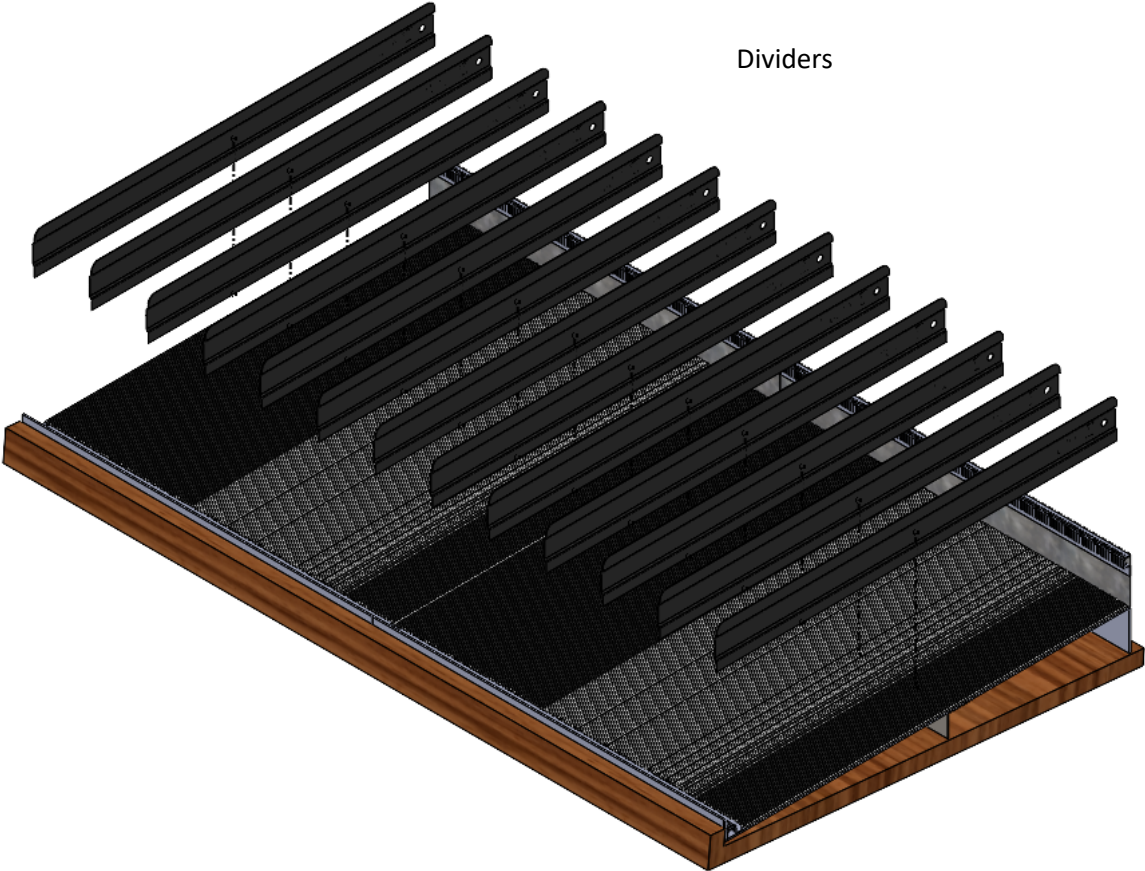

Dividers to be secure in the slots, round side must be up and all indents must go the same way in each shelf

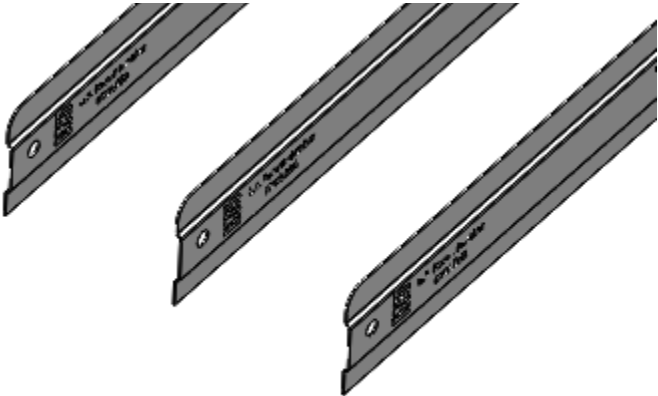

Laying two products down in each lane is a helpful way to set lane dividers.

Step 3: Install Plexiglass front product stop into the Plexi Holder slots.

Plexiglass Front
Product Stop

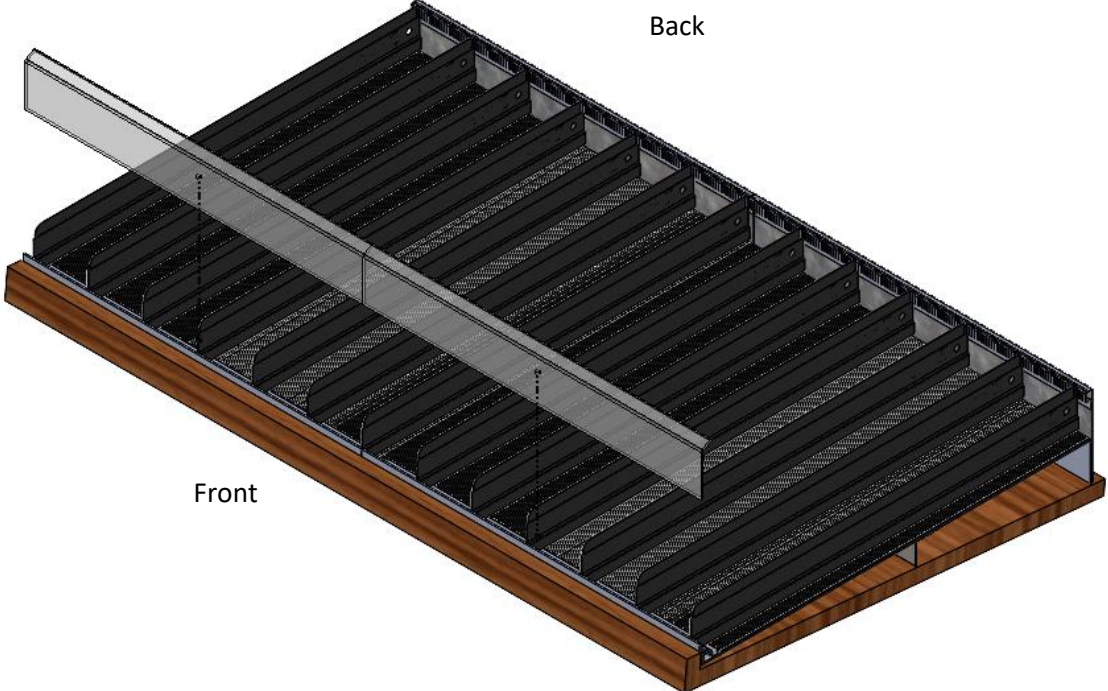

Completed Assembly:

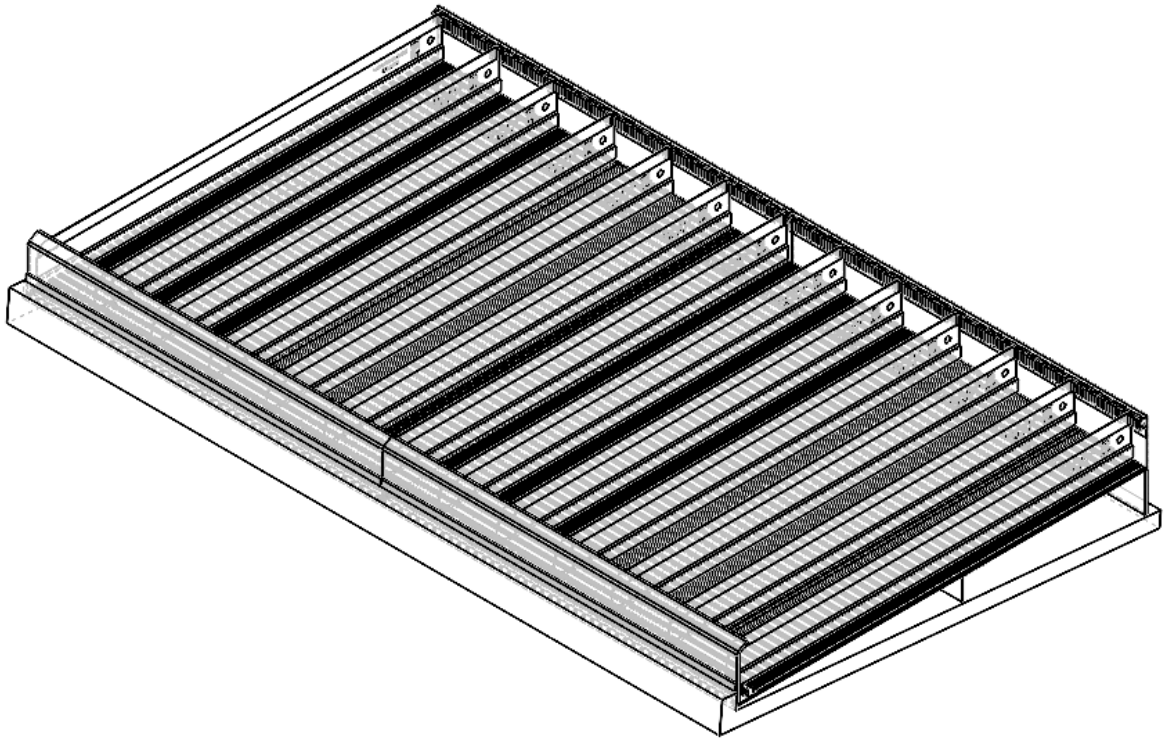

Questions?

Call Customer Service...800-323-2517