

VERSAPALLET SHELVES ASSEMBLY GUIDE



Intertek

Sanitation Listed
Certified to NSF/ANSI 2 by Intertek

-Size of parts will differ depending on customer's order.

-Quantity of parts might differ depending on customer's order.

NEED:



Two people
needed



Utility
Gloves

PARTS LIST

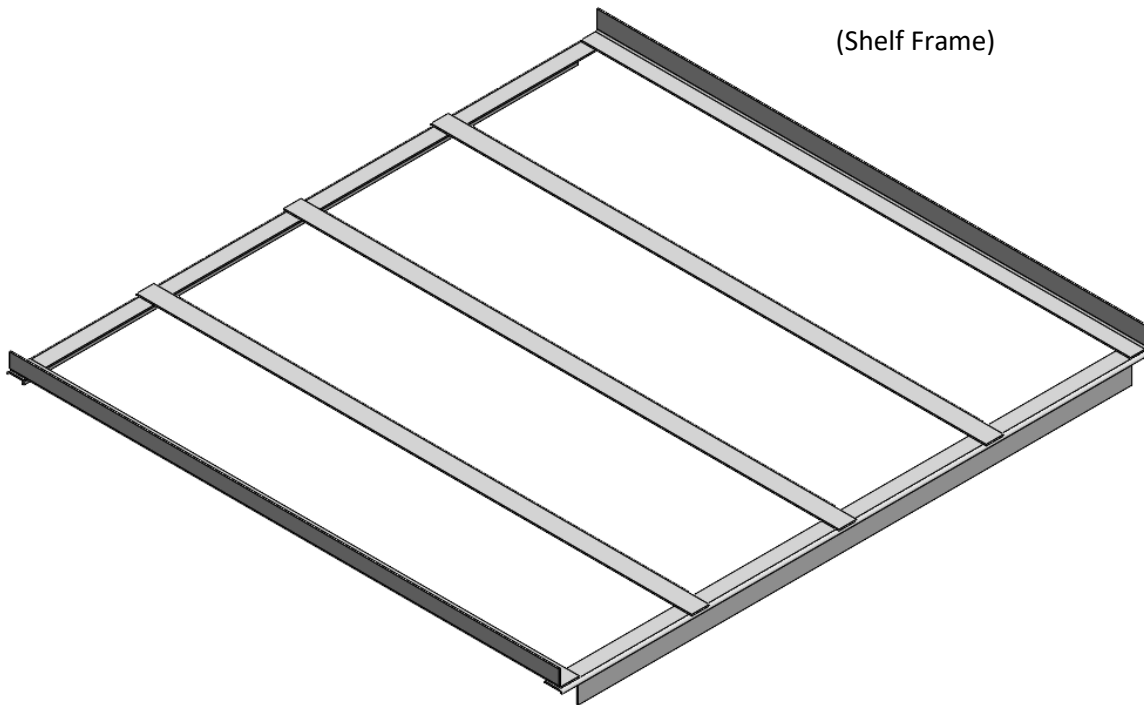

(Shelf Frame)

(Wire Mat)

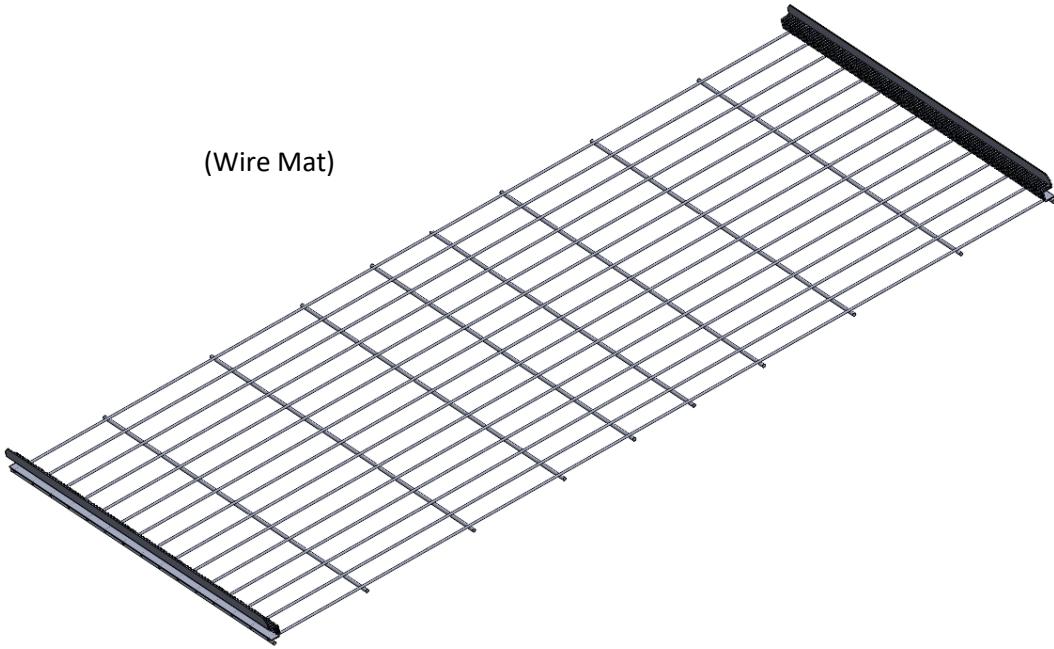

(Glide Sheet)

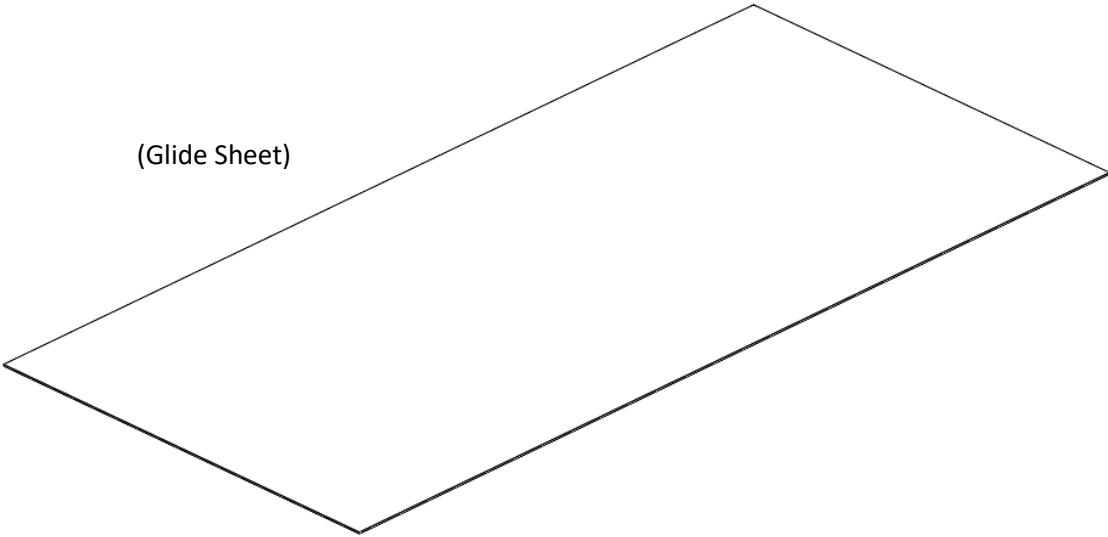

(Side Dividers)

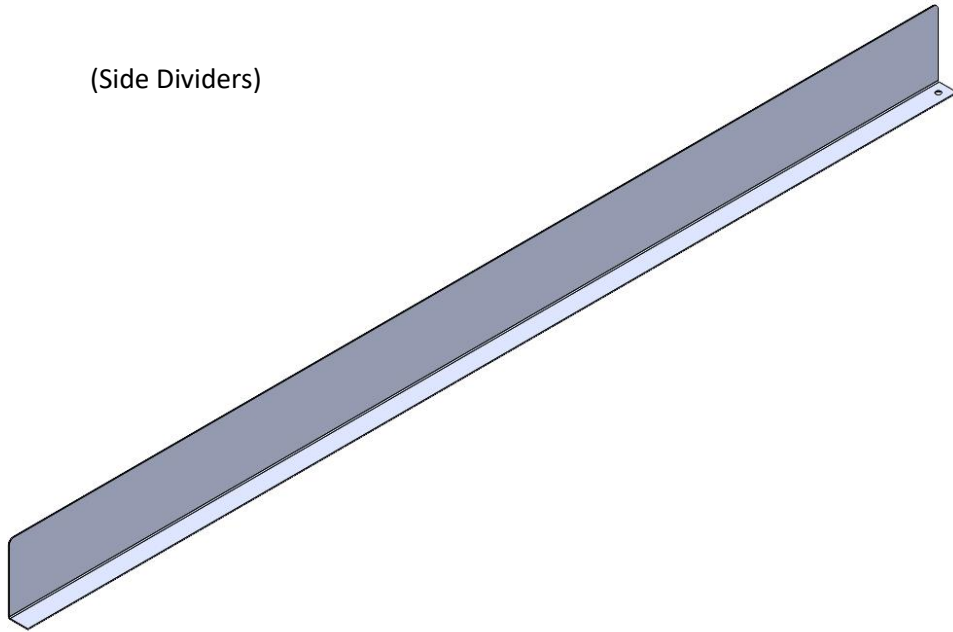

(Inner Dividers)

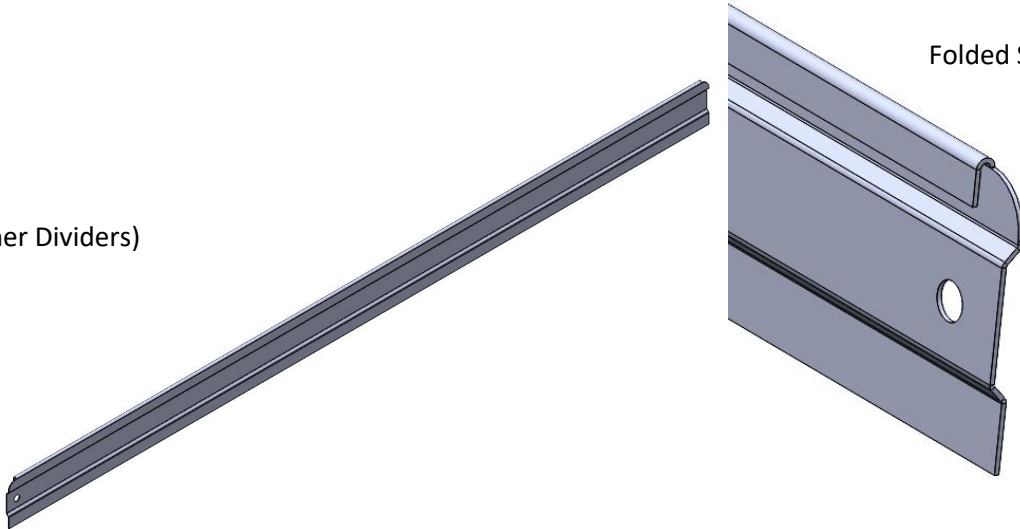

Folded Side Up

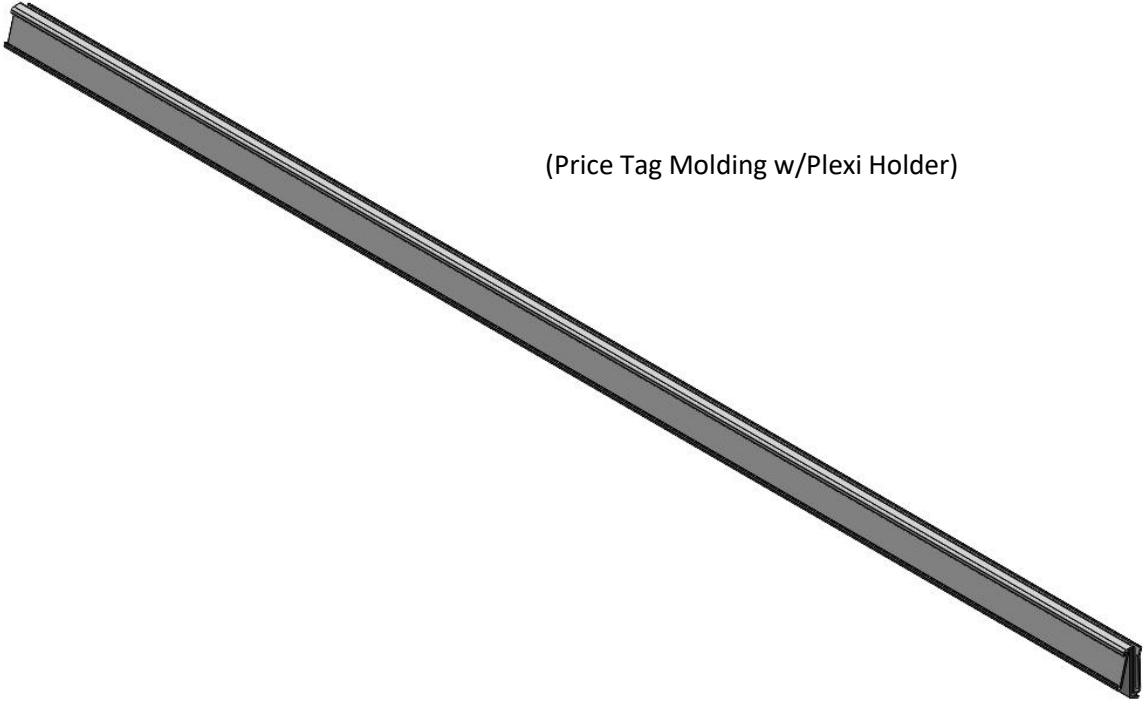

(Price Tag Molding w/Plexi Holder)

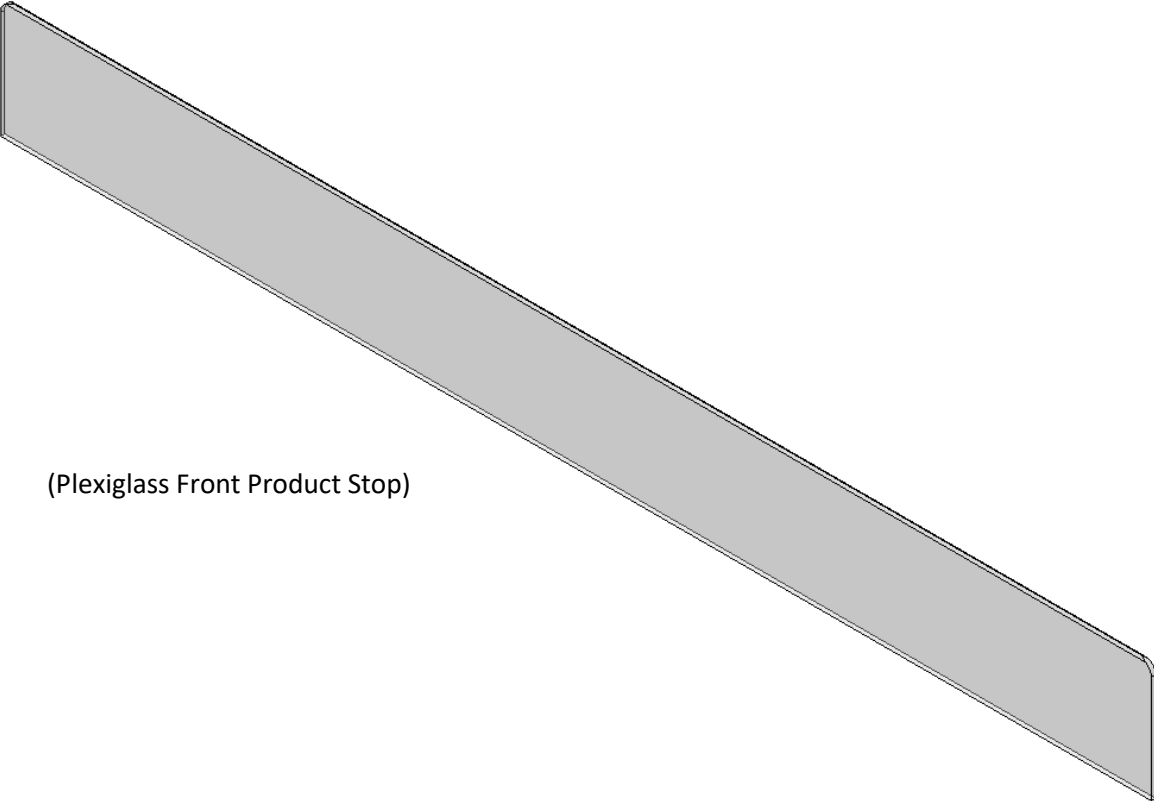

(Plexiglass Front Product Stop)

Step 1: Set the Shelf Frame in the existing Pallet Rack beam (4') with this specific profile.

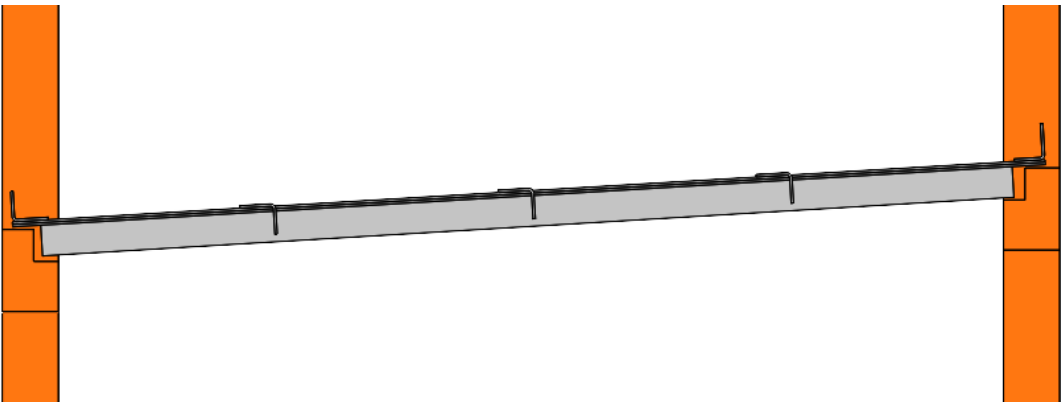
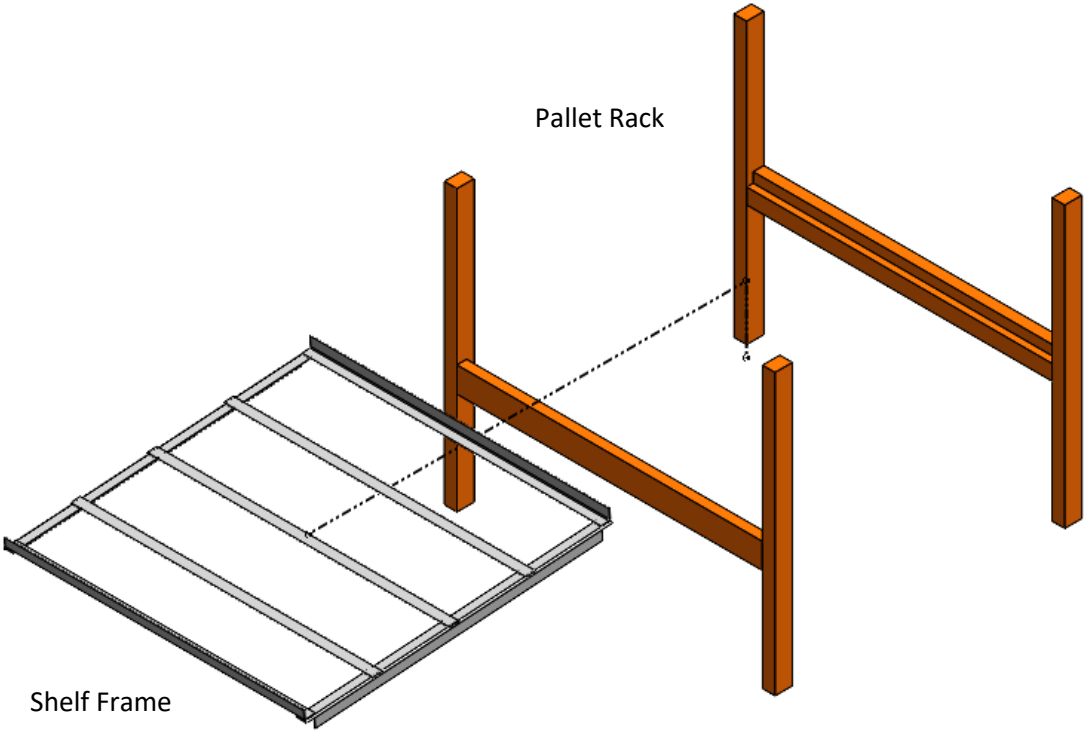

Step 2: Set the Price Tag Molding on the Shelf Frame.

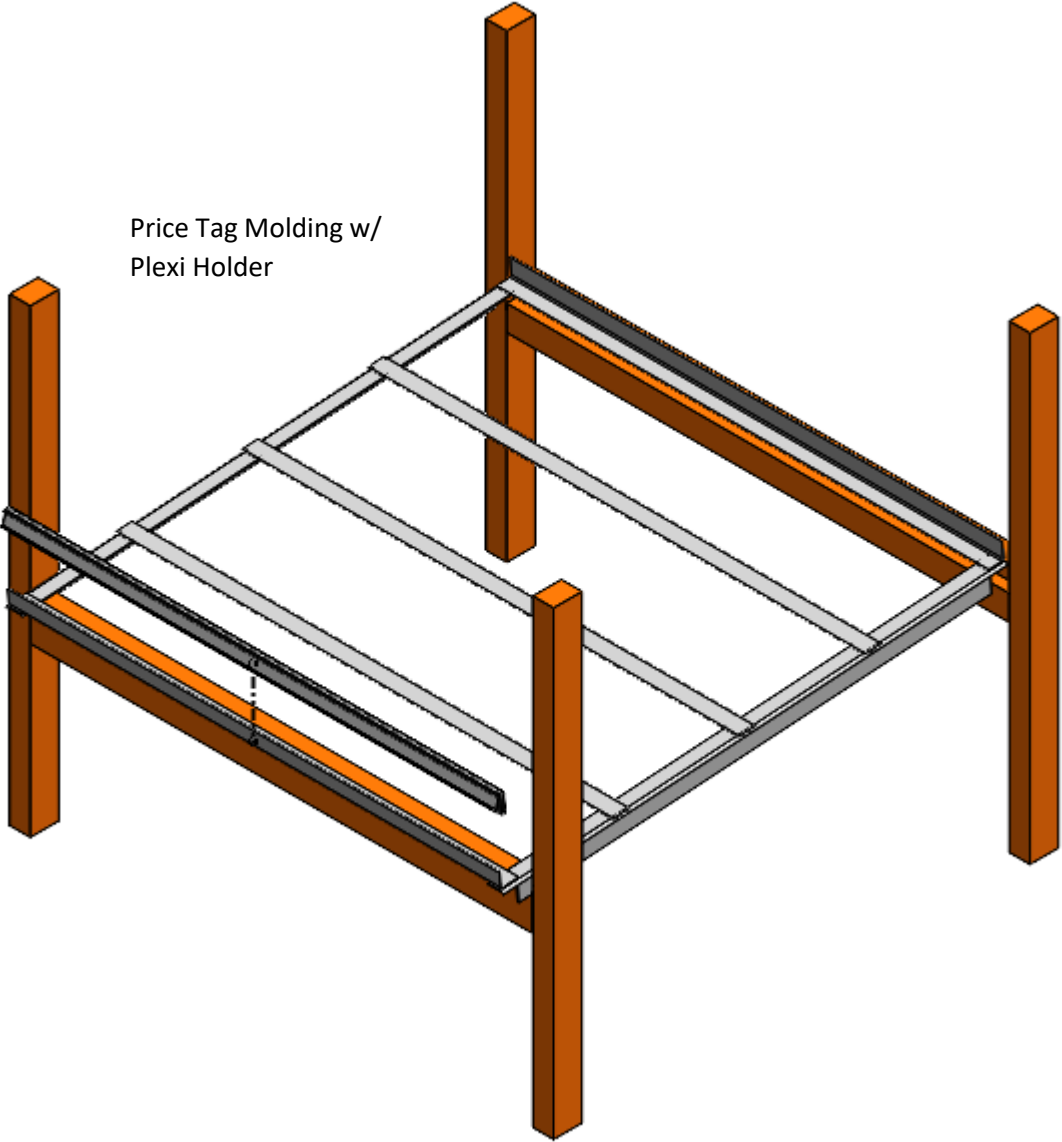

Step 3: Set the Side Dividers, Wire Mats & Glide Sheets on the Shelf Frame.

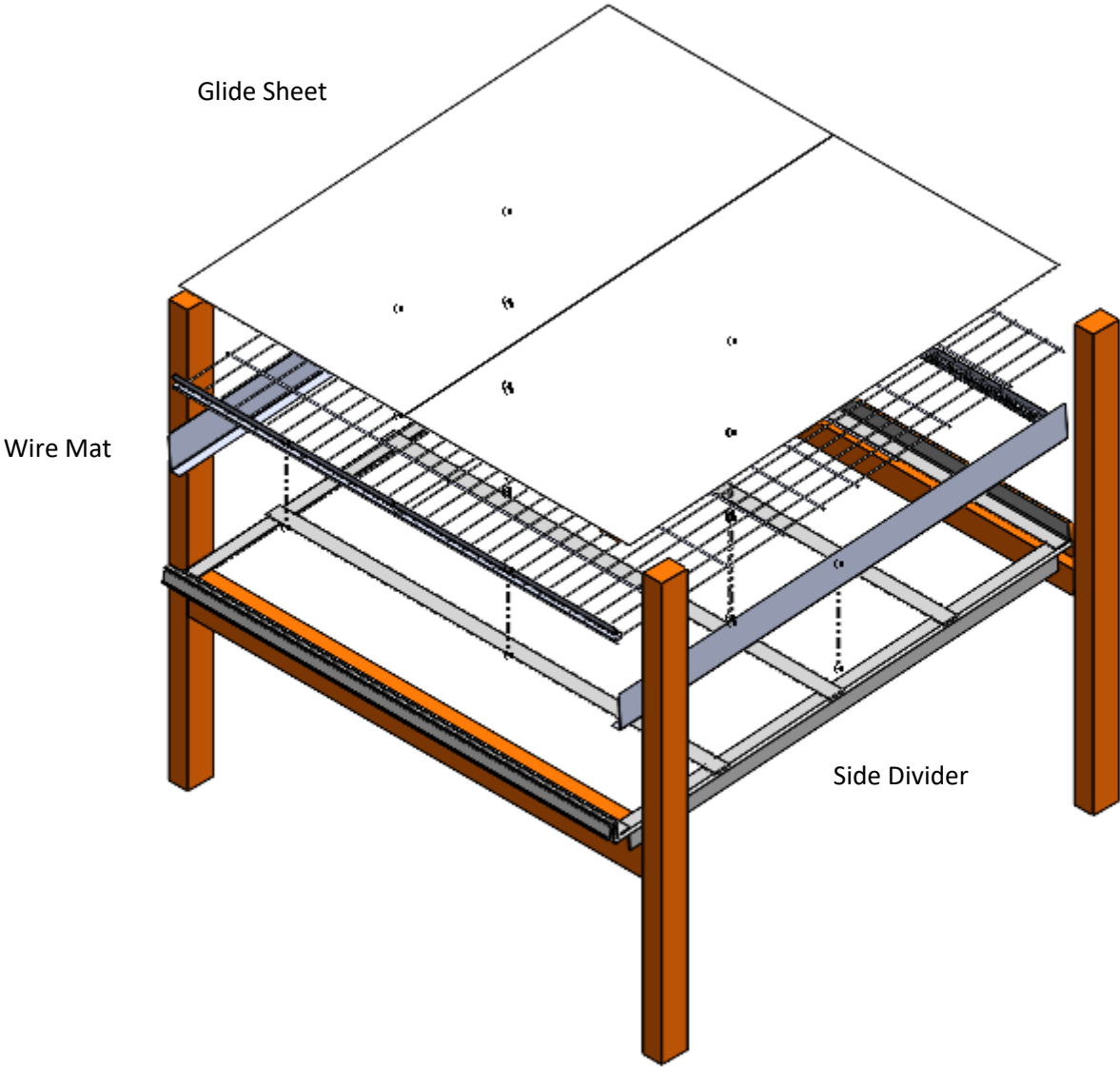

Step 4: Set Inner Dividers.

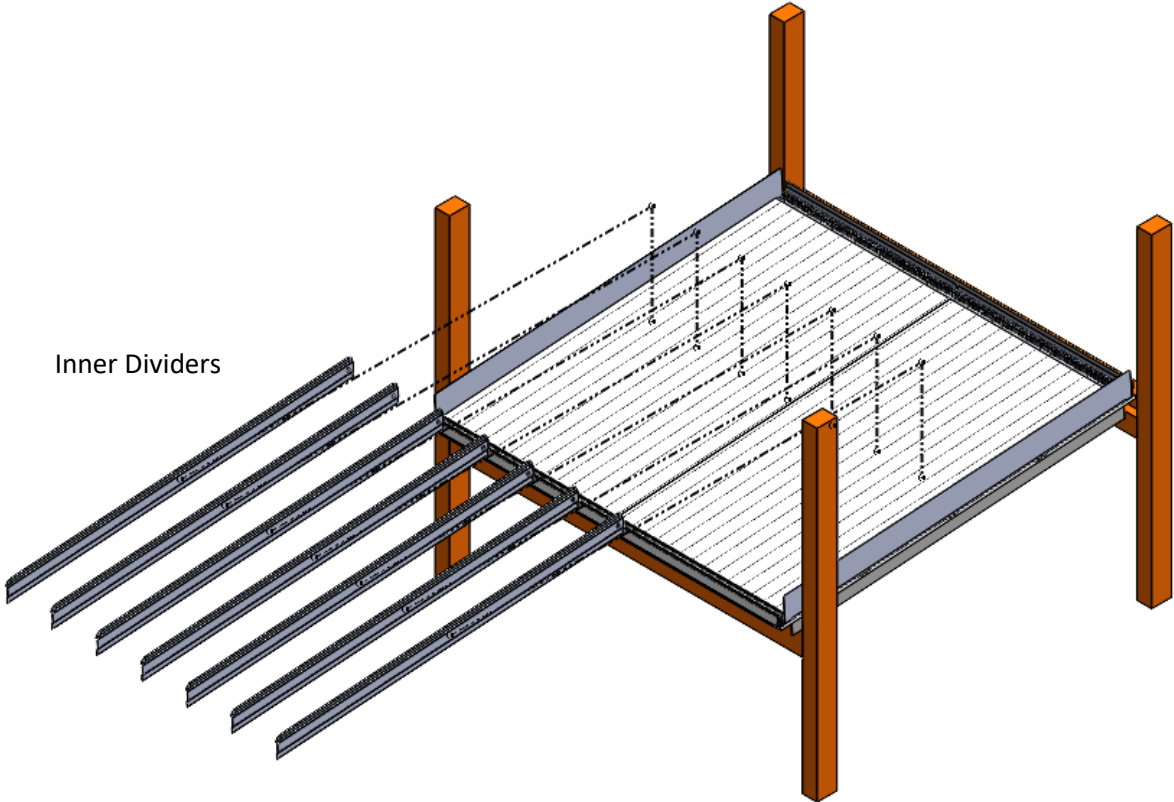

Dividers to be secure in the slots, folded side must be up and all indents must go the same way in each shelf

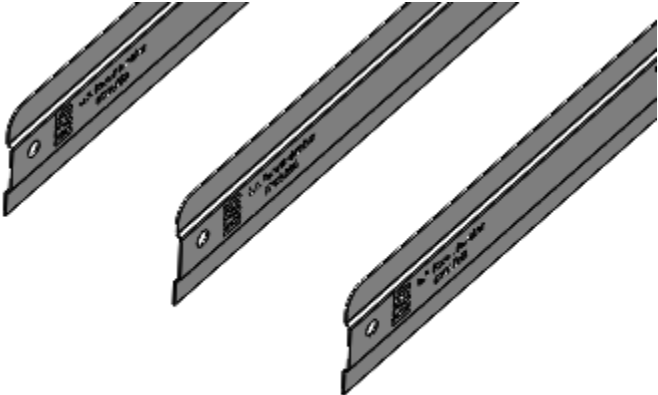

Laying two products down in each lane is a helpful way to set lane dividers.

Step 5: Install Plexi Glass in the Price Tag Molding Plexi Holder.

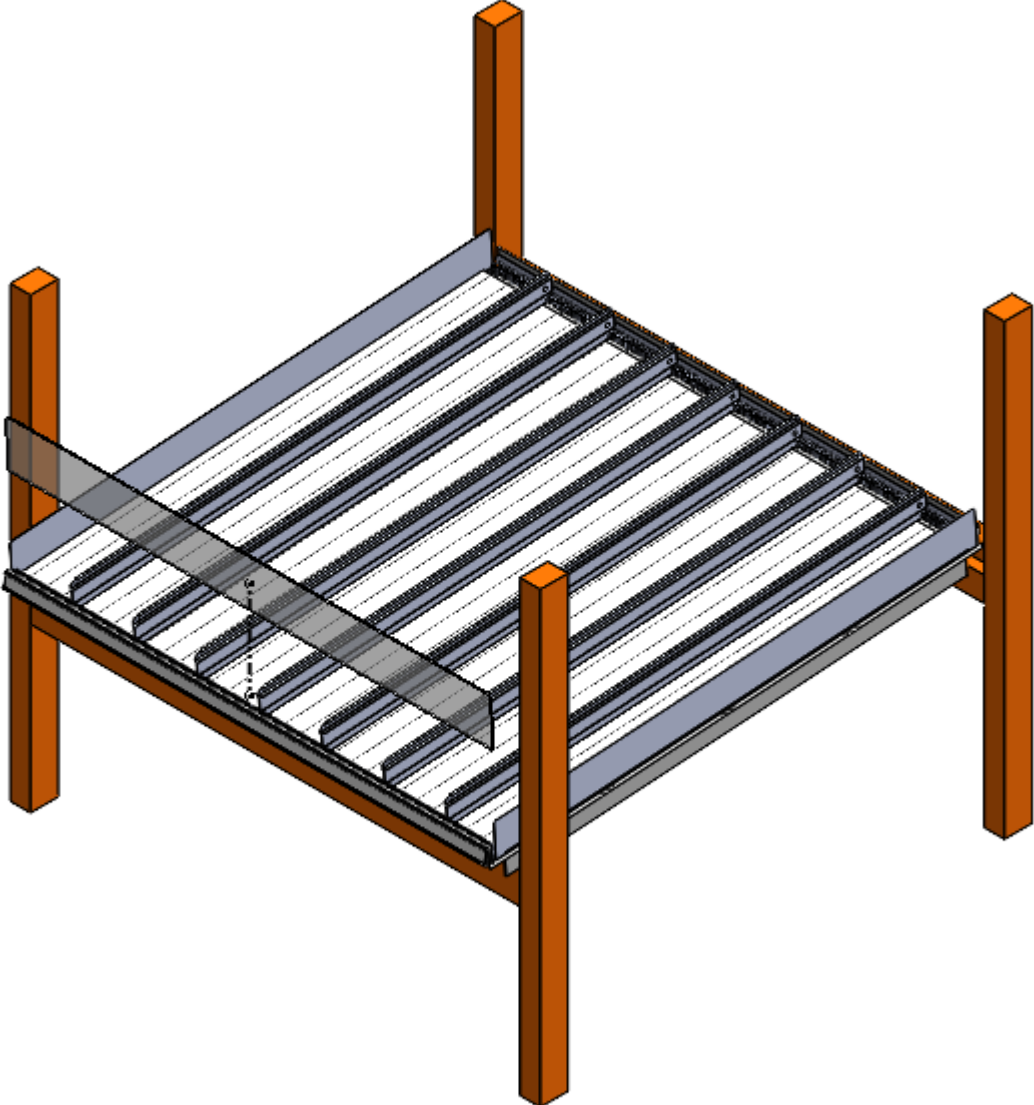

Completed Assembly:

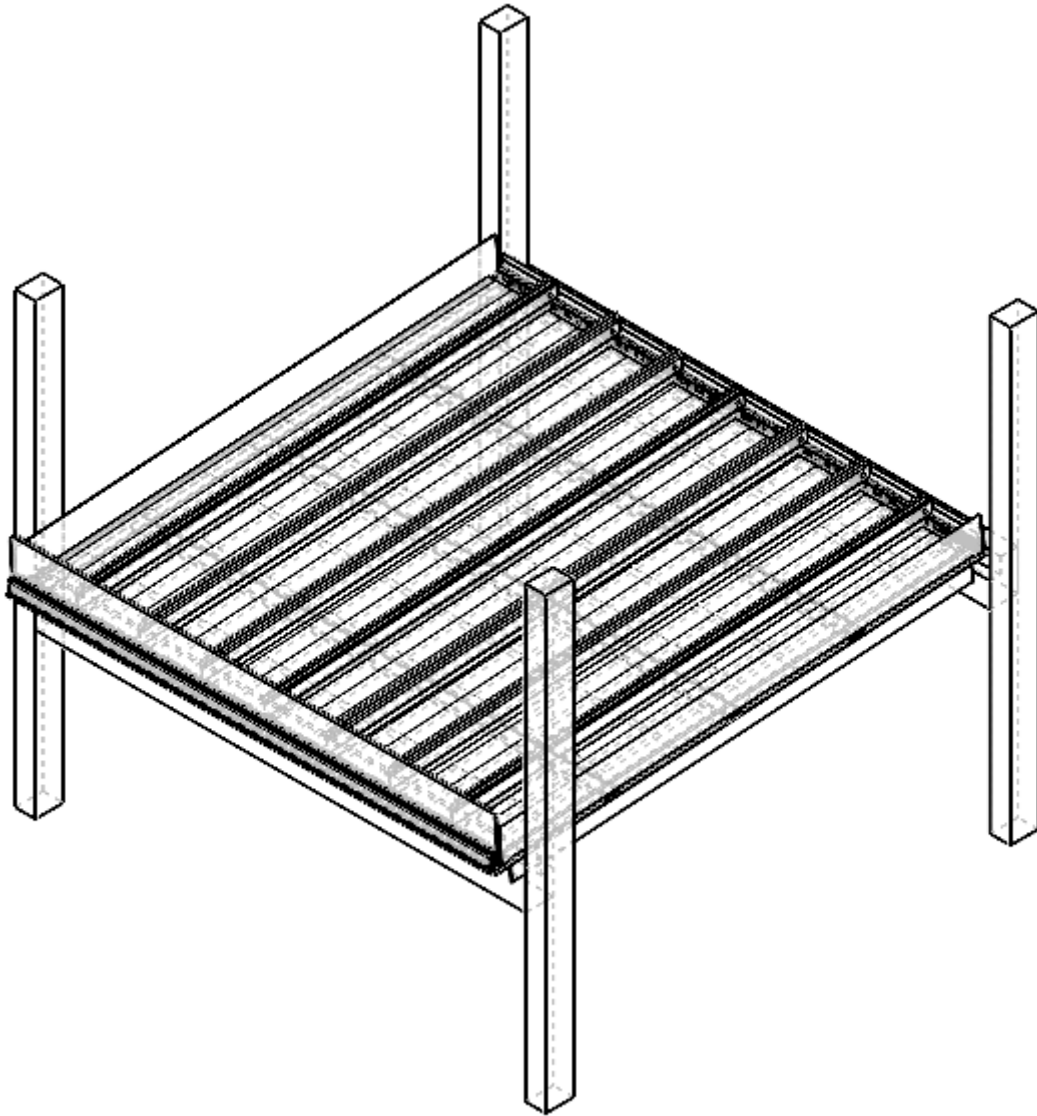

Questions?

Call Customer Service...800-323-2517