

# VERSARACK + EZ CLEAN

## GUIA DE ENSAMBLAJE



**Intertek**

Sanitation Listed  
Certified to NSF/ANSI 2 by Intertek

- Tamaño de partes pueden diferir dependiendo de la orden del cliente.
- Cantidad de partes pueden diferir dependiendo de la orden del cliente.

Requiere:



Dos personas



Llave de 1/2" & Ratchet con tubo profundo de 1/2"



Nivelador



Guantes de Trabajo

Lista de Partes

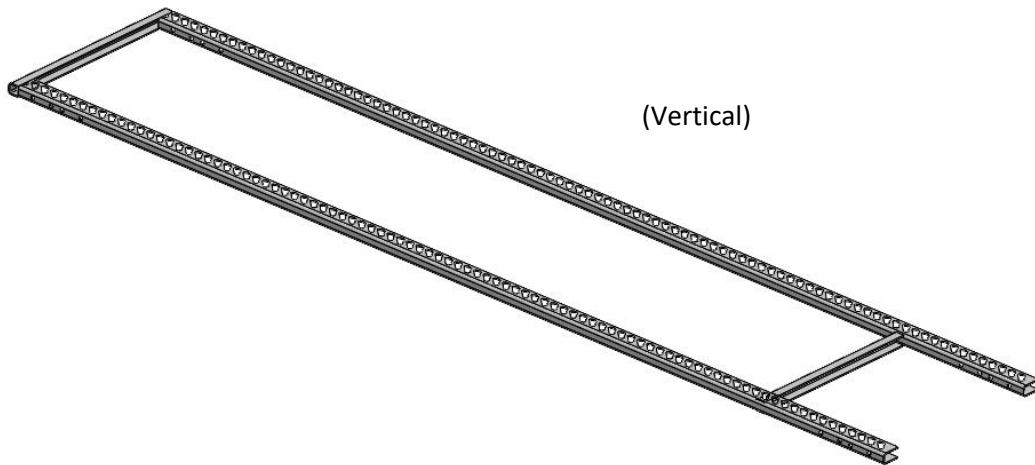

(Vertical)

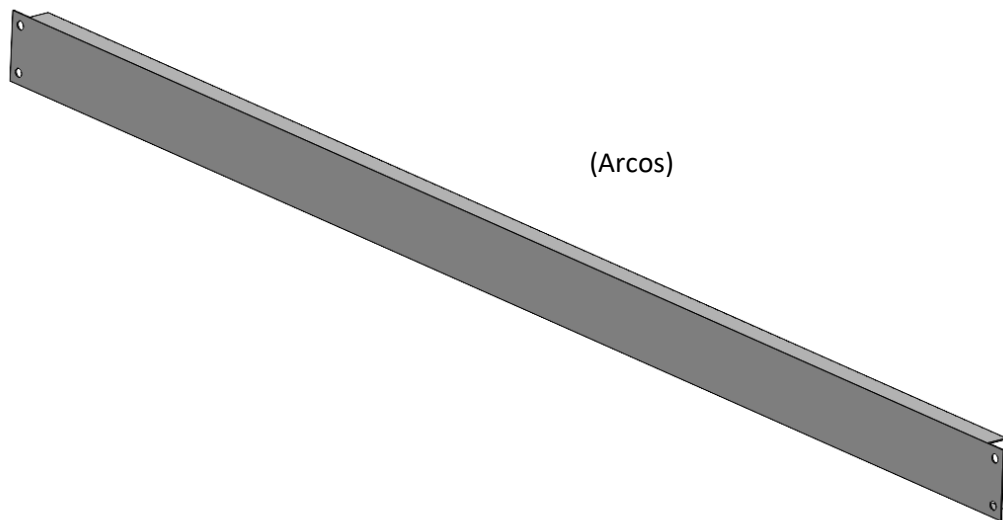

(Arcos)

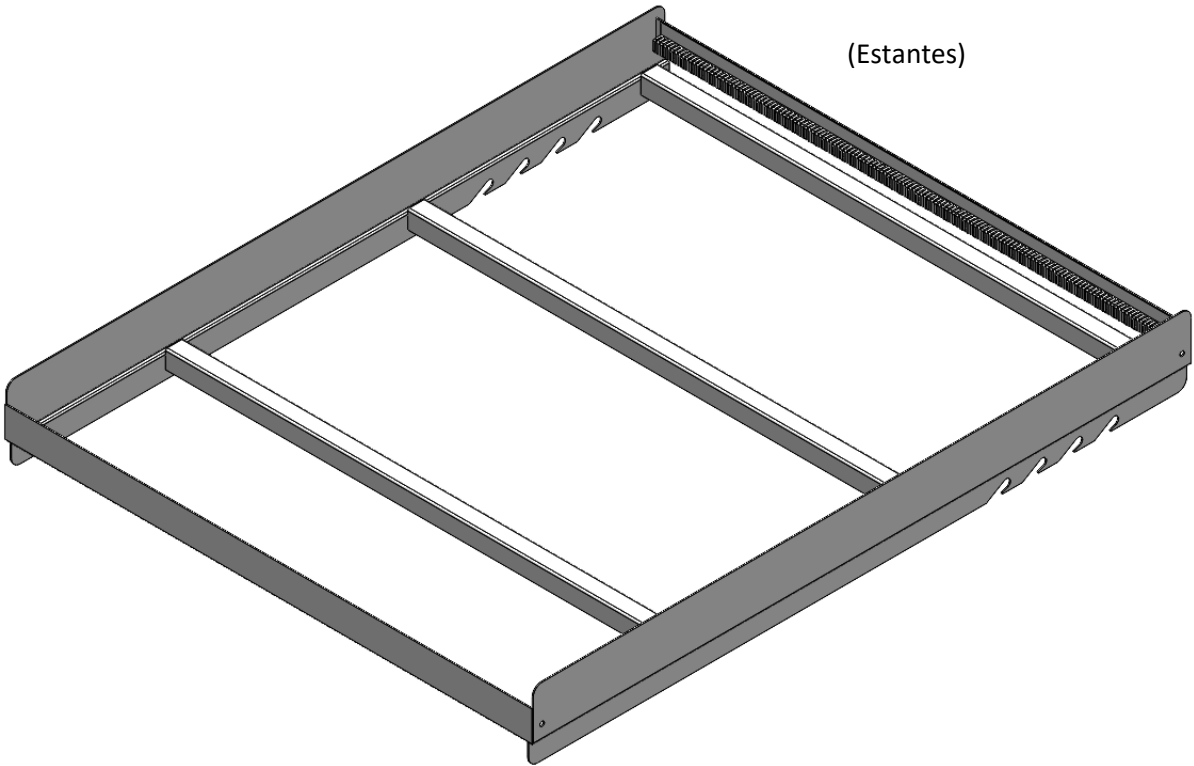

(Estantes)

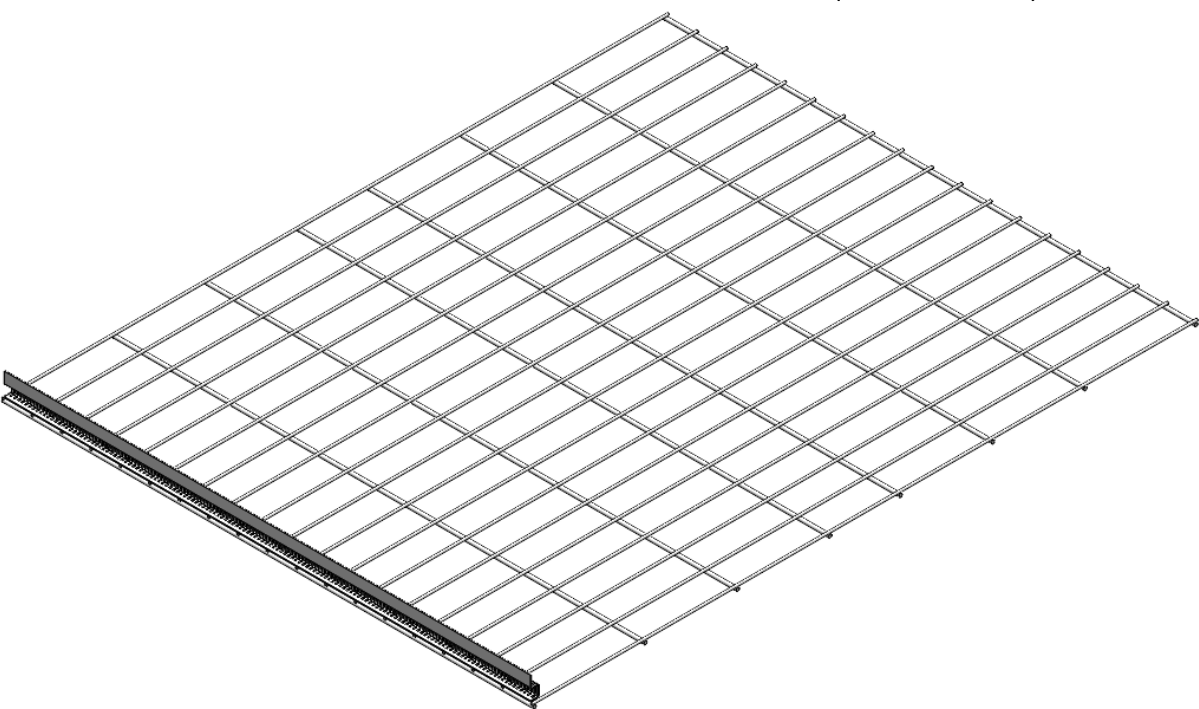

(Cama de Cables)

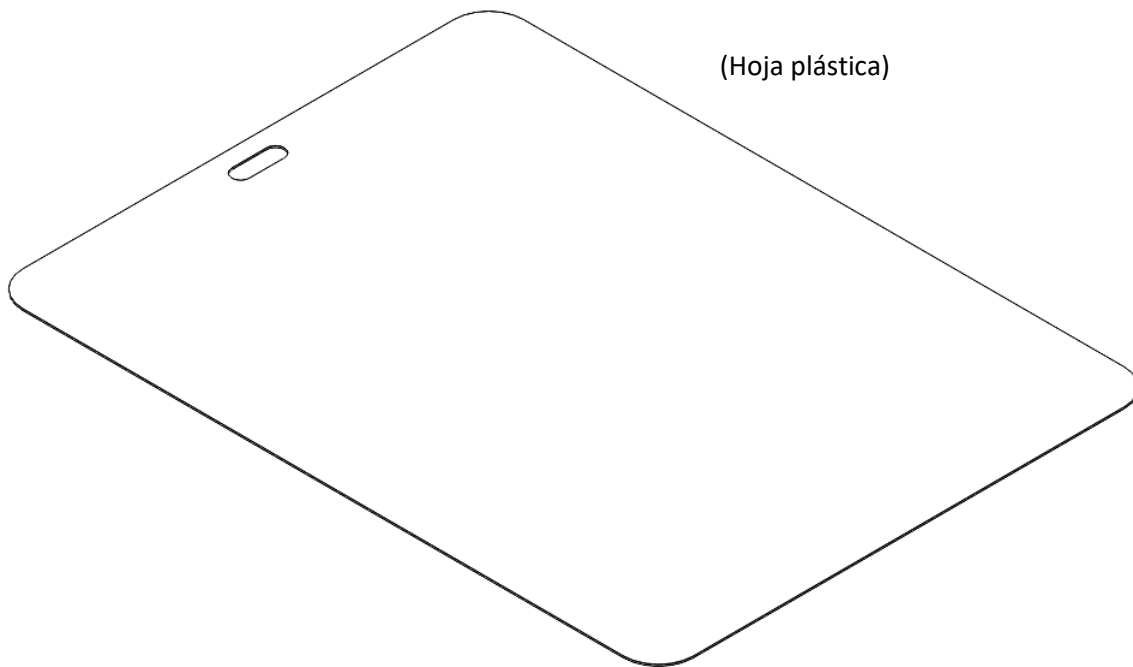

(Hoja plástica)

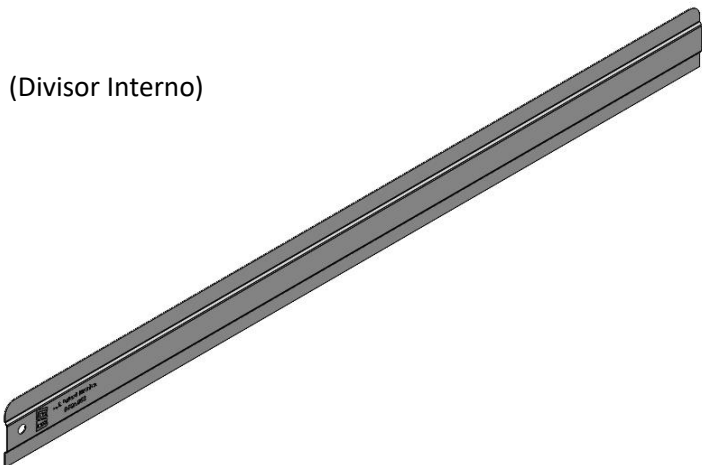

(Divisor Interno)

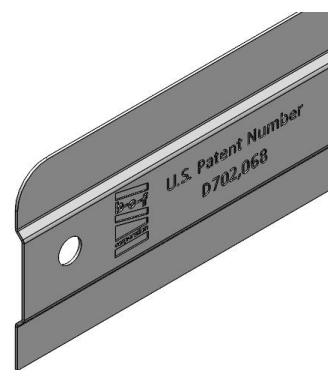

Parte redonda hacia

(Molde de precio Frontal  
c/Soporte de Plexiglass)

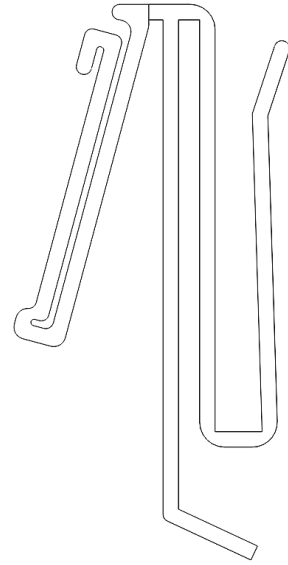

(Molde de  
precio Trasero)

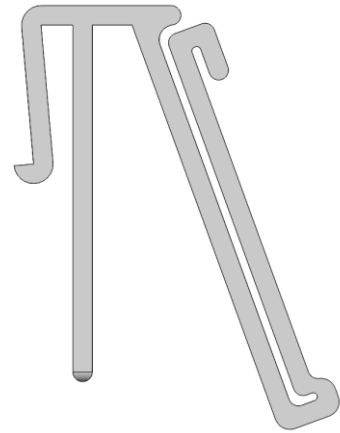
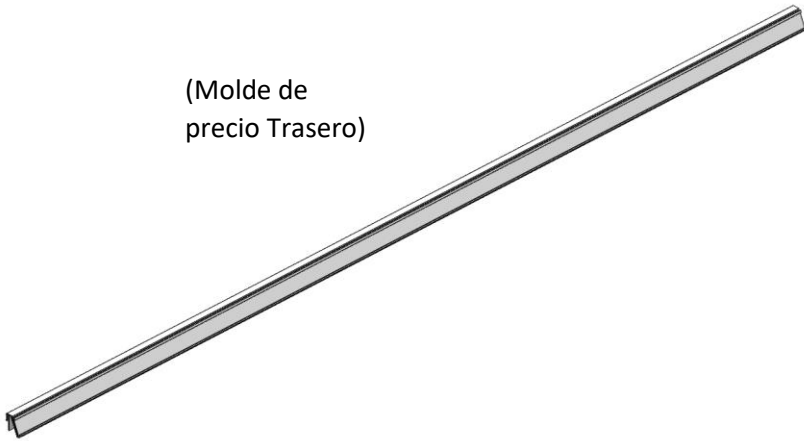

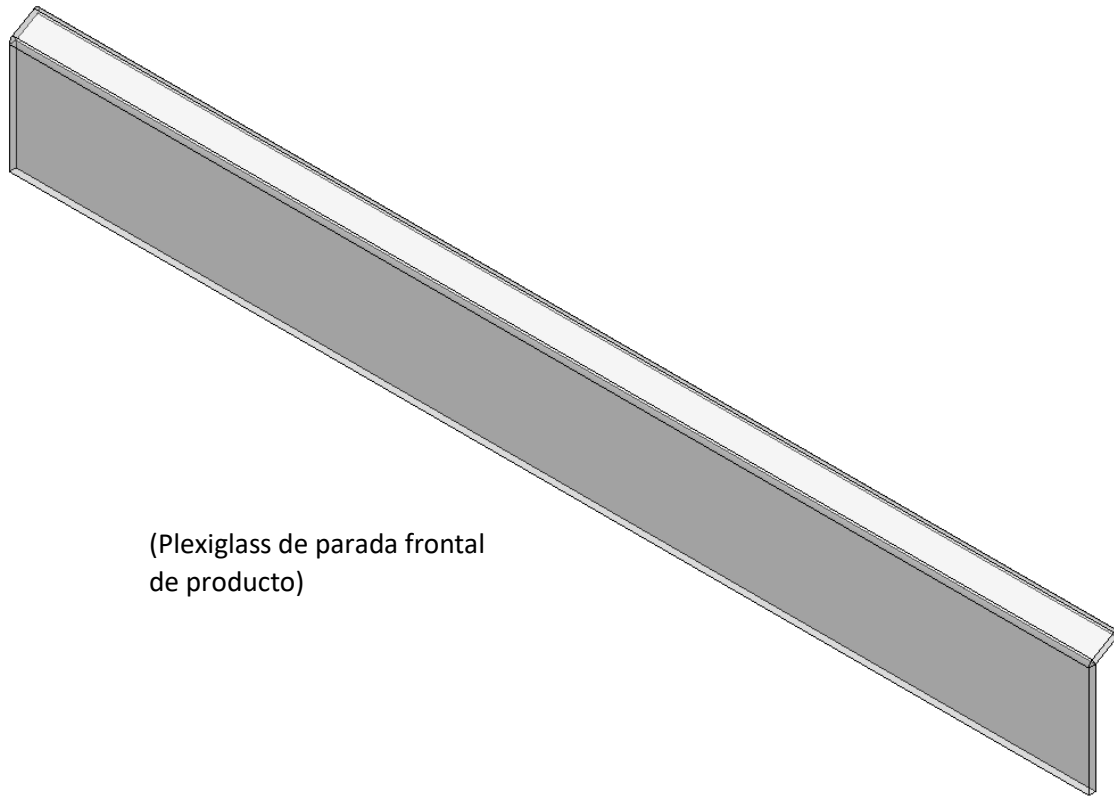

(Plexiglass de parada frontal de producto)

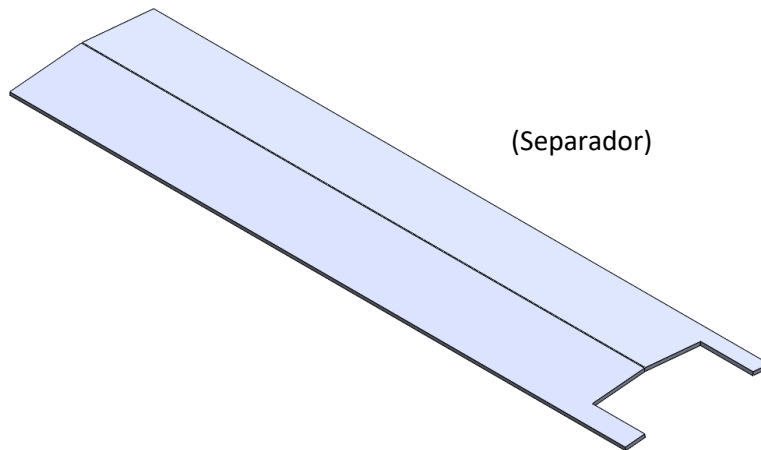

(Separador)



Gancho de estante

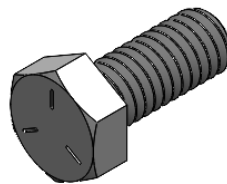

Tornillo de 5/16"

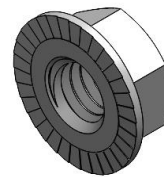

Tuerca de 5/16"

**Paso 1: Apretar con los dedos**, dejar las tuercas apretadas con los dedos. **NO** apretar con llaves hasta el final. Locación sugerida de arcos son frente superior y trasero inferior. Cada sección debe tener 6 pulgadas de arco.

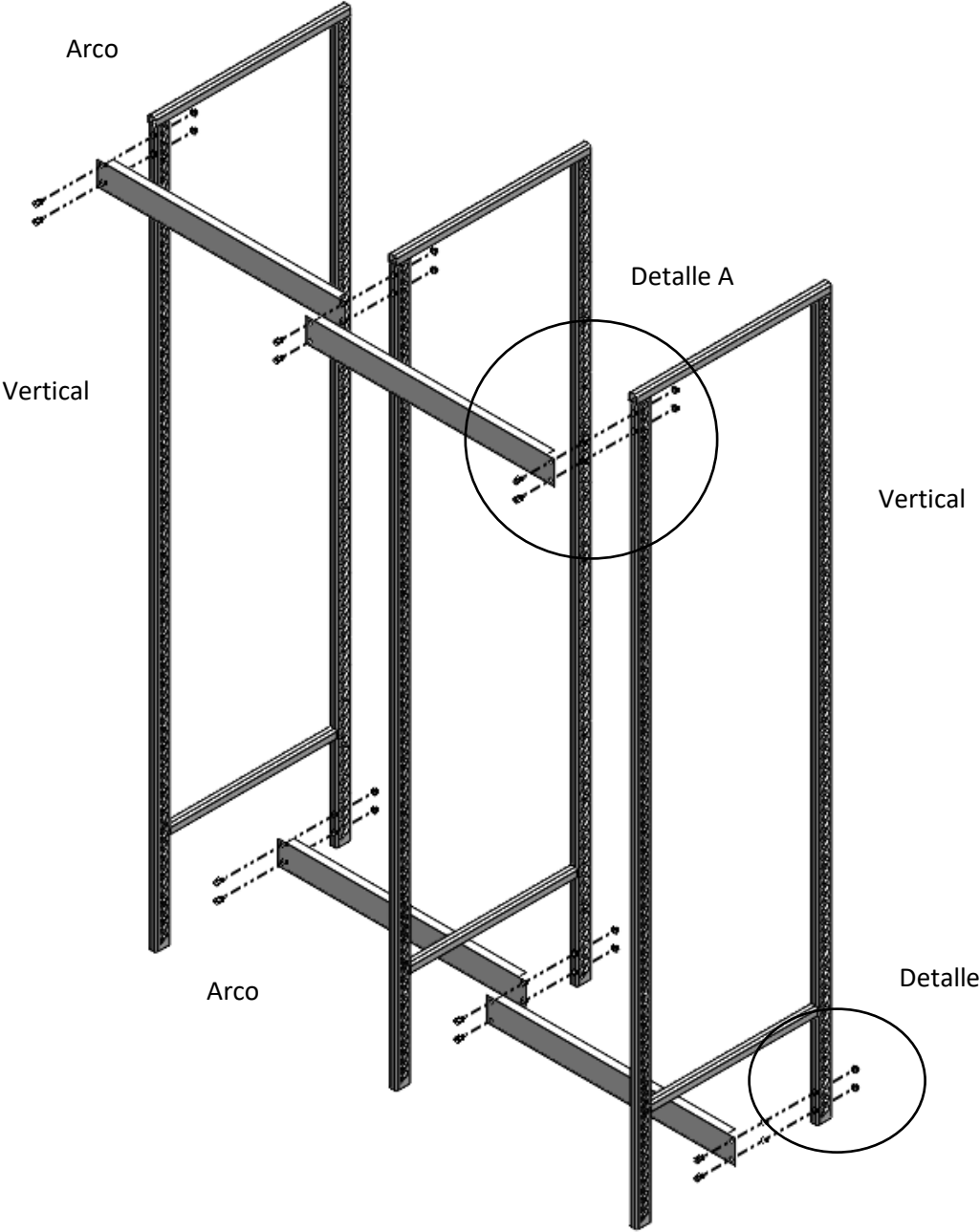

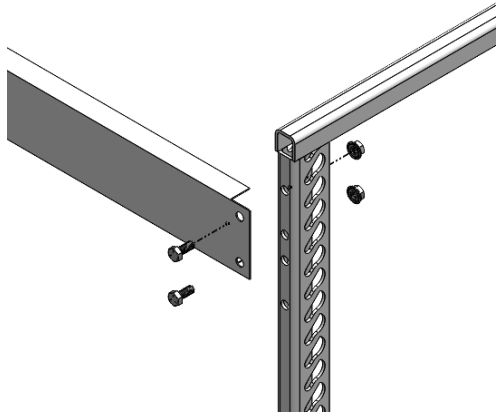

Detalle A

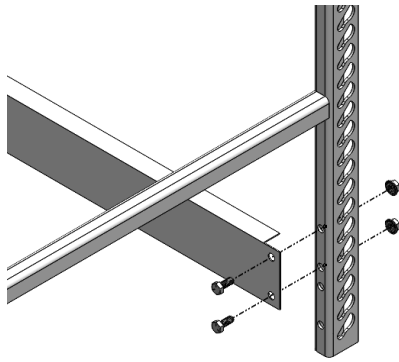
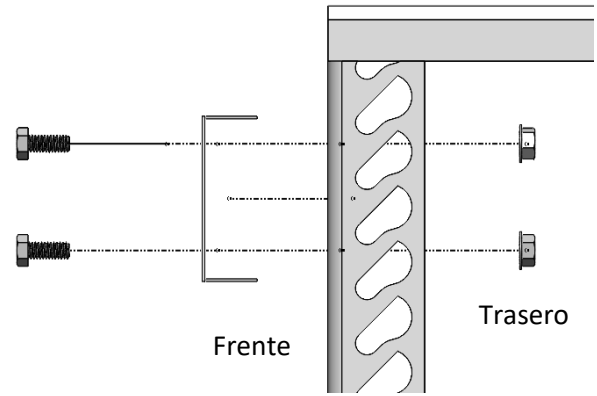

Detalle B

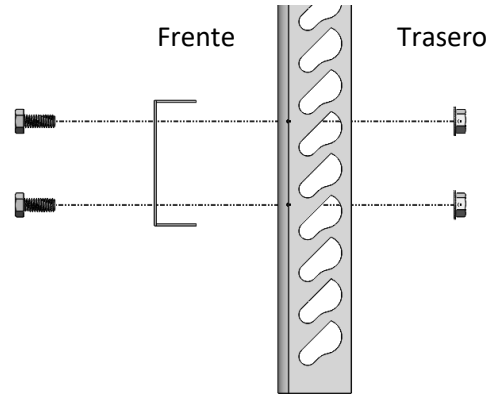



Los marcos de puerta vienen en 2, 3, 4 o 5 por sección, 5 es el máximo número de puertas por sección. Los marcos de estantes deben alinearse con los marcos de puertas. La división entre sección puede identificarse por una barra T desde el lado del cliente de las puertas, o donde puedas ver dos luces desde el lado del producto de las puertas.

Vista Frontal

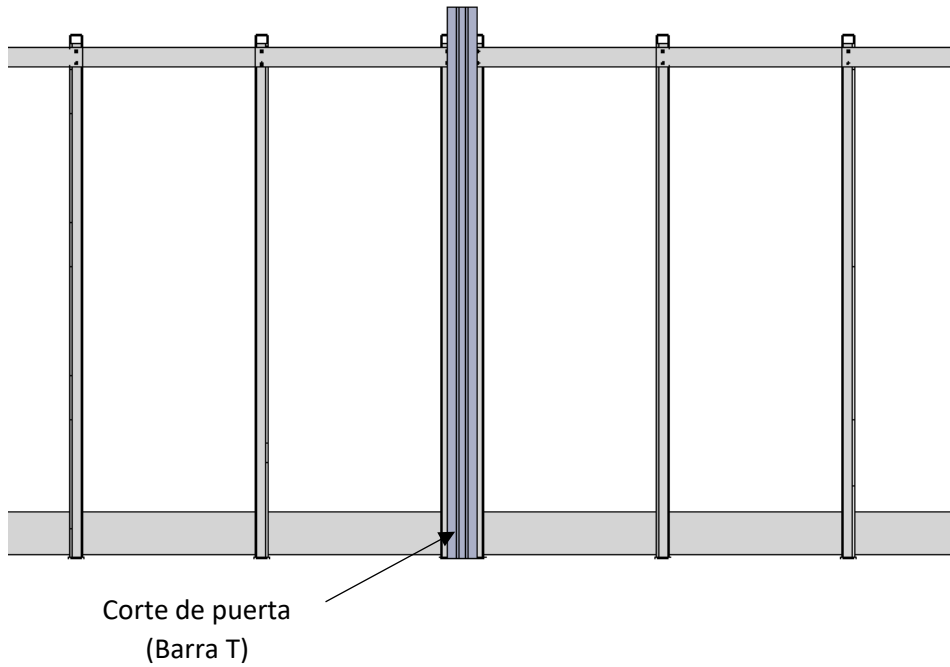

Vista Aerea

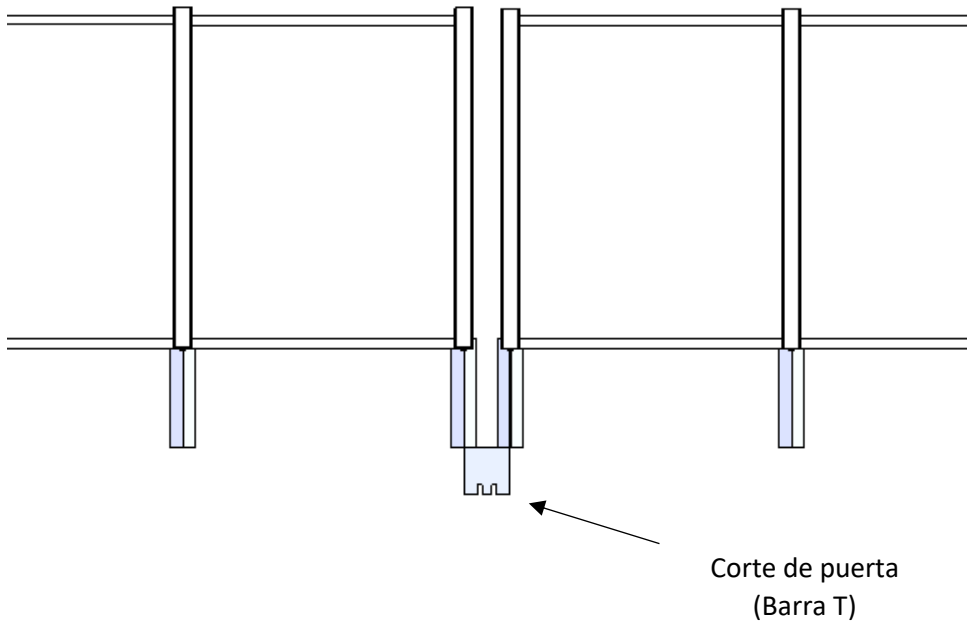

**Paso 2:** Use separadores para indicar el espacio del vertical de la puerta.

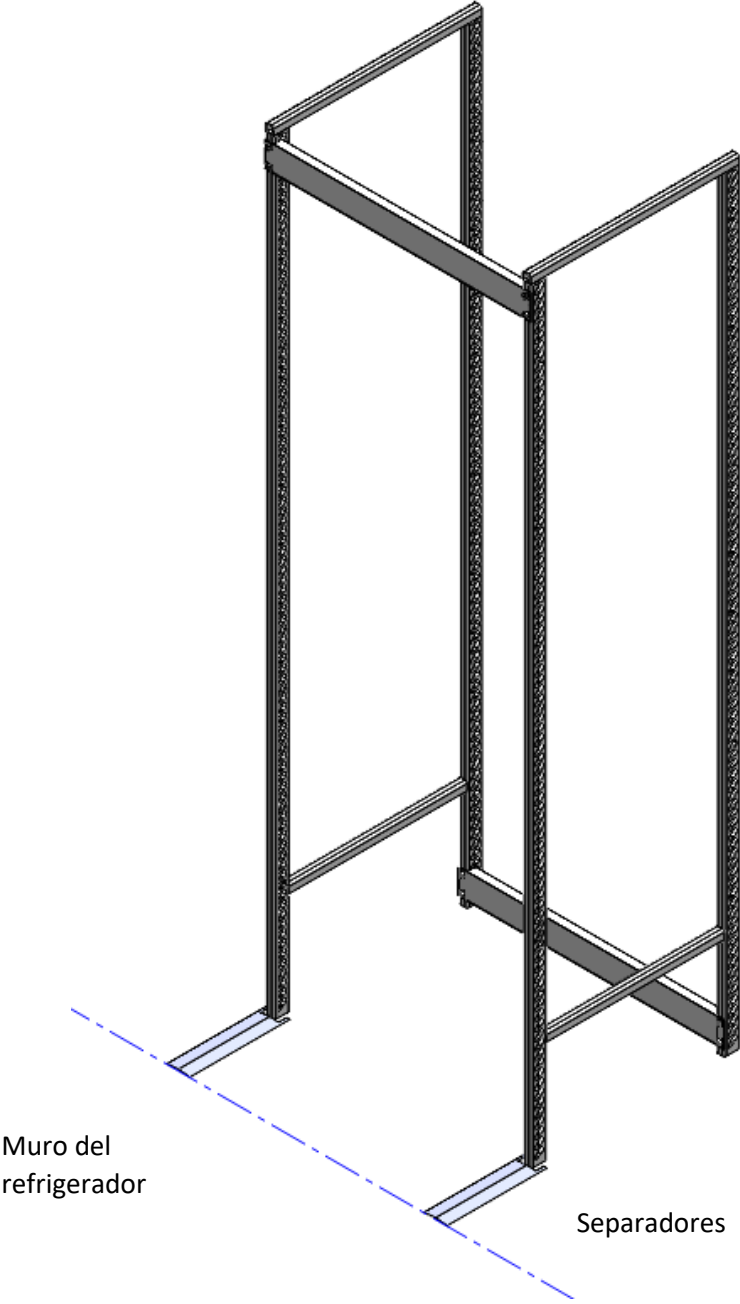

**Paso 3:** Coloque los ganchos de estantes en el marco del vertical para colocar los estantes.

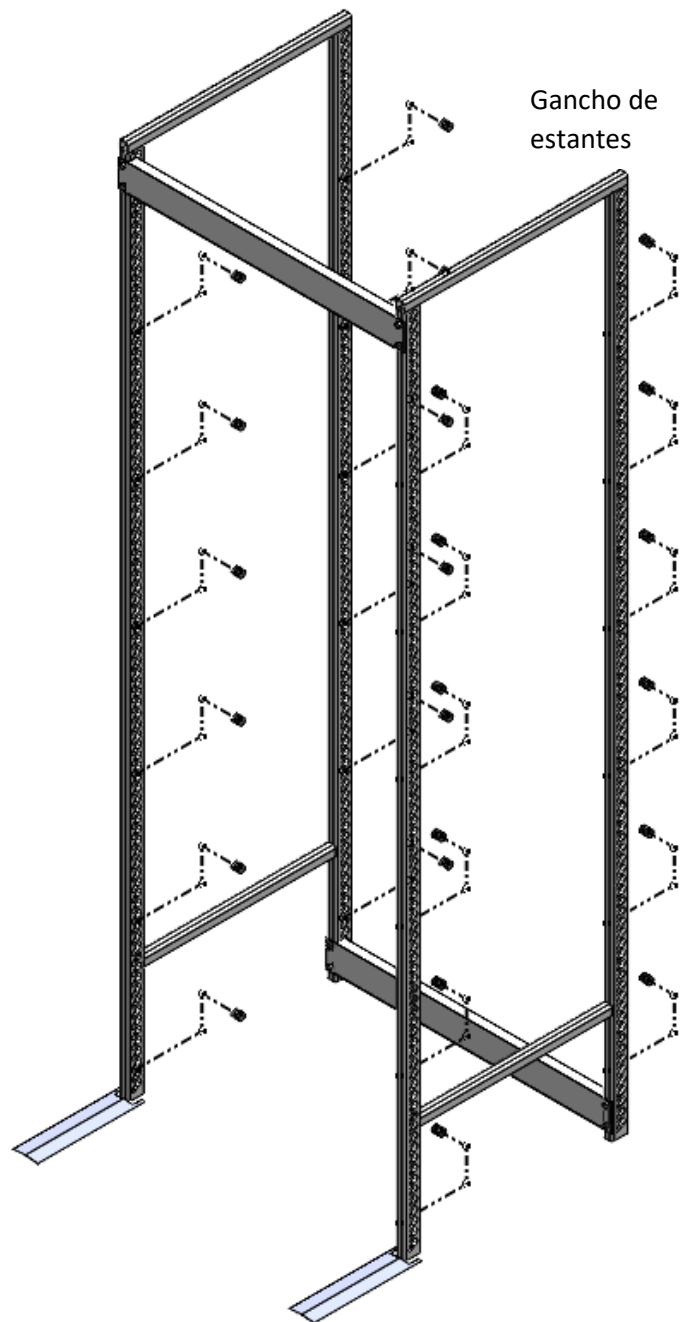

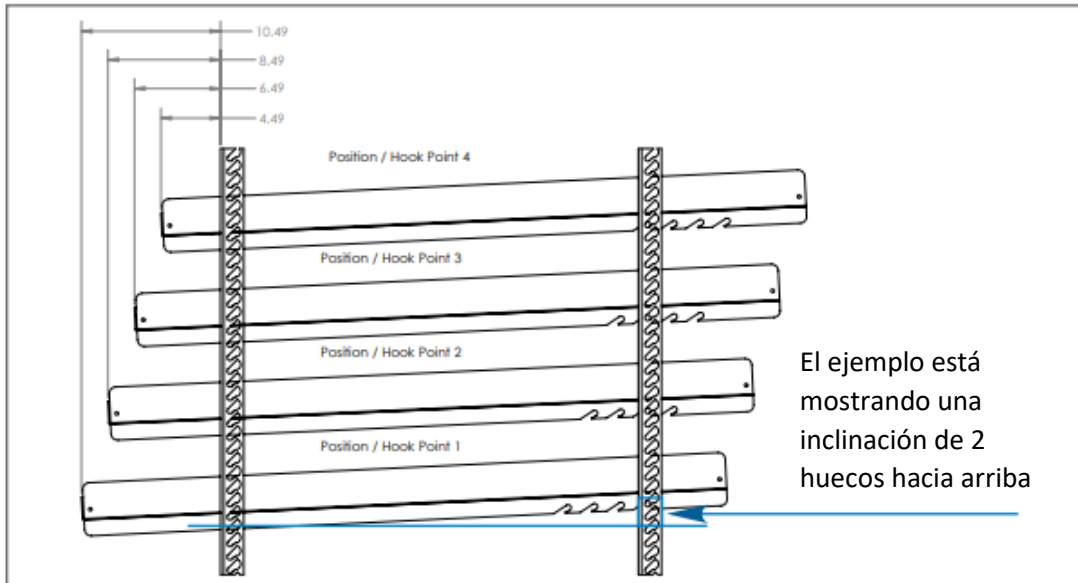

### 27" Shelf Depth

Product	Number of keyholes notches up
Plastic beverage	3
Carton beer	4
Cardboard water	4
Liquid dairy	3
Liquid dairy	4
Glass packaged	2

### 36" Shelf Depth

Product	Number of keyholes notches up
Plastic beverage	4
Carton beer	4
Cardboard water	4
Liquid dairy	4
Liquid dairy	4
Glass packaged	2

### 48" Shelf Depth

Product	Number of keyholes notches up
Plastic beverage	5
Carton beer	5
Cardboard water	5
Liquid dairy	5
Liquid dairy	5
Glass packaged	3

**Paso 4:** Instale **únicamente** los estantes Superior e Inferior. Use un nivelador para asegurarse que la estructura esté recta.

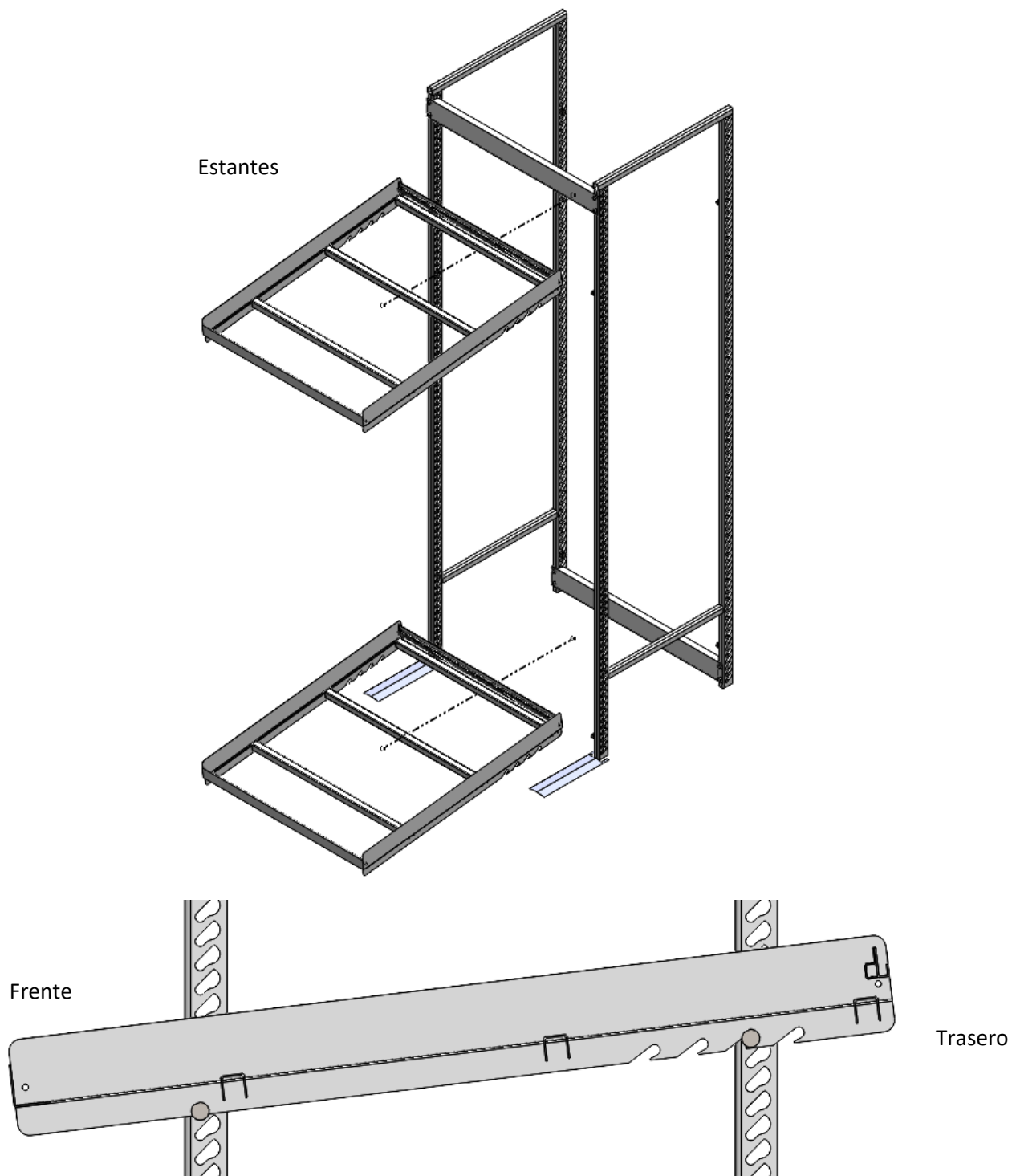

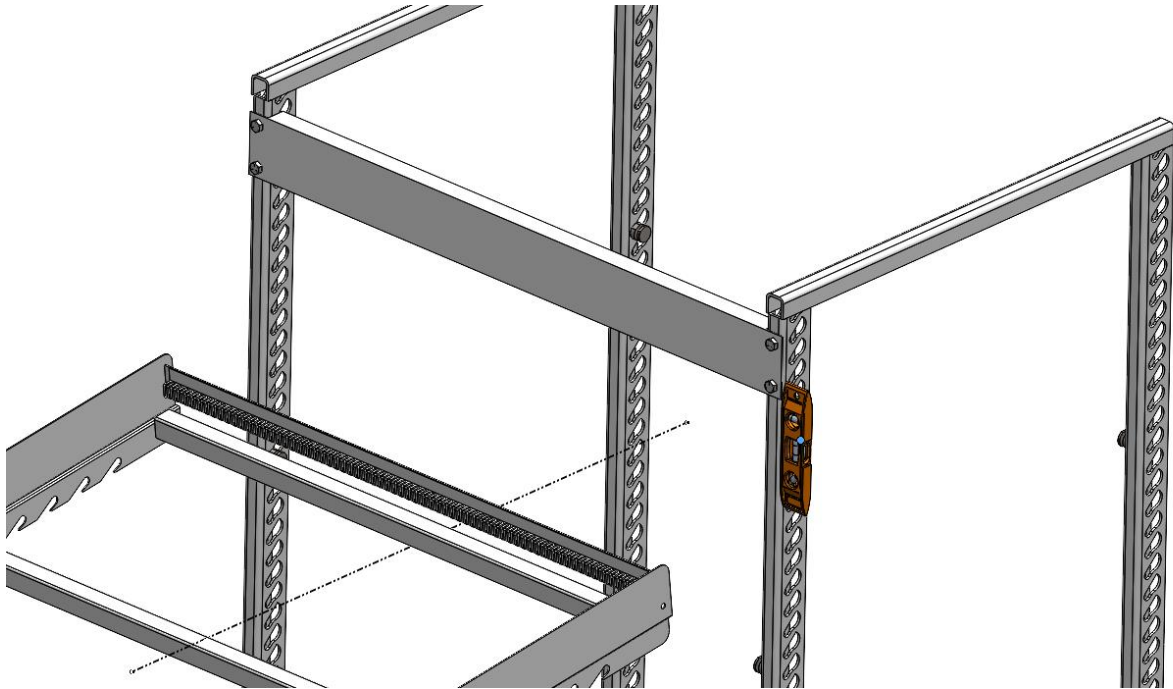

Paso 5: **Apriete** todos los tornillos usando las llaves.

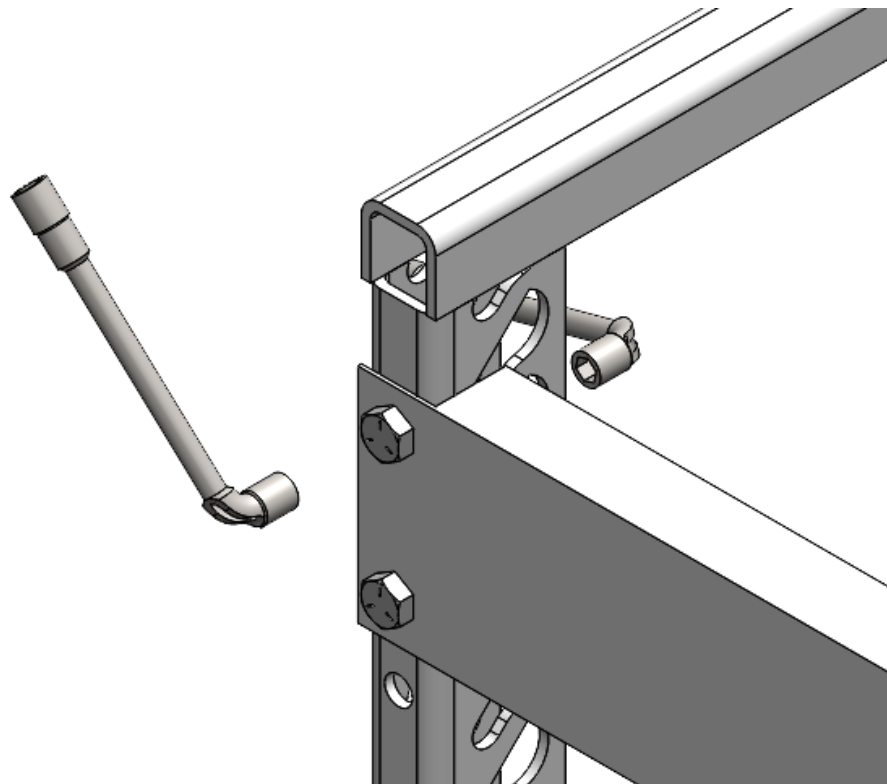

**Paso 6:** Coloque el resto de los estantes.

Estantes

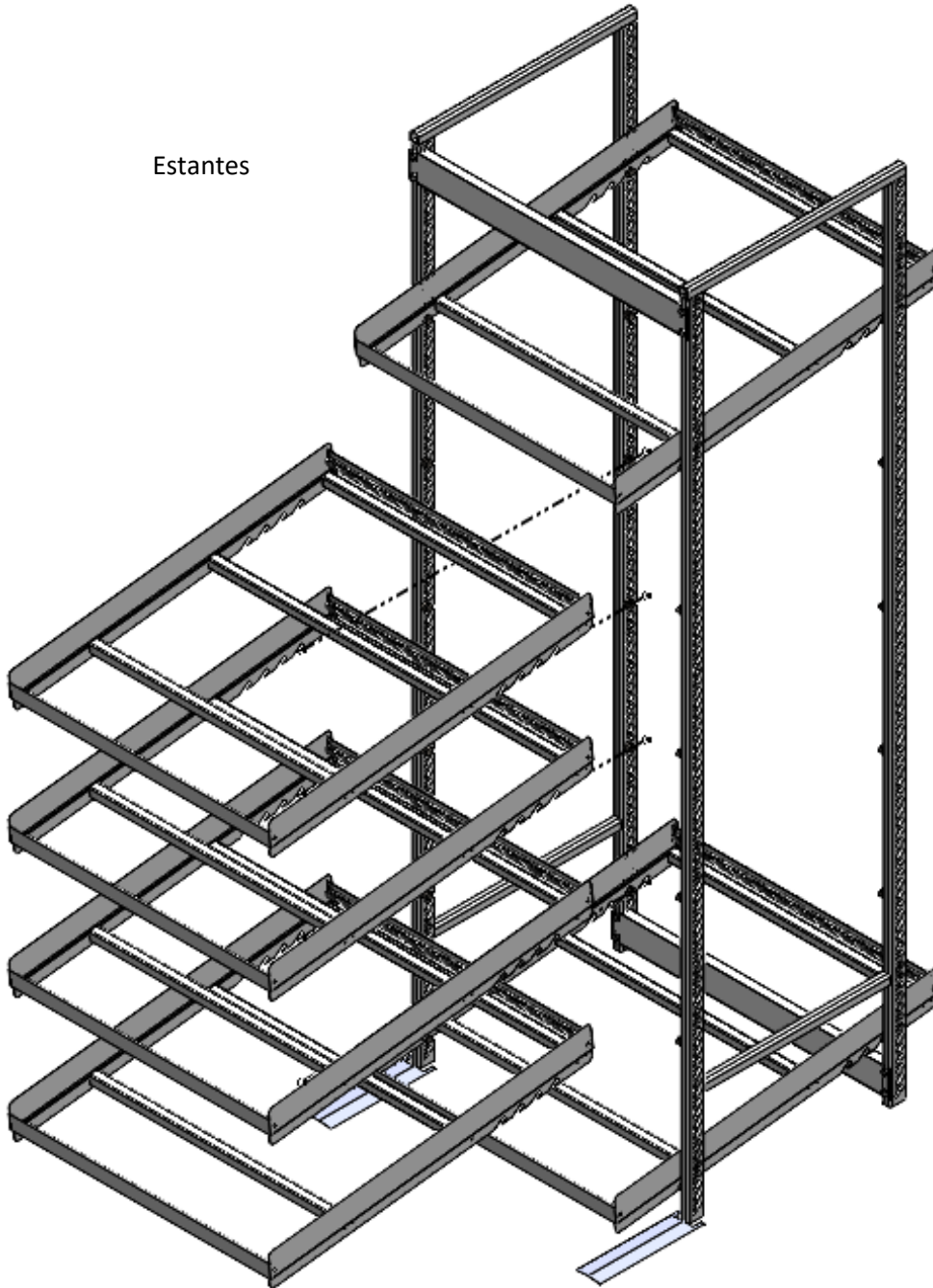

**Paso 7:** Instale los Moldes de precio frontal y trasero.

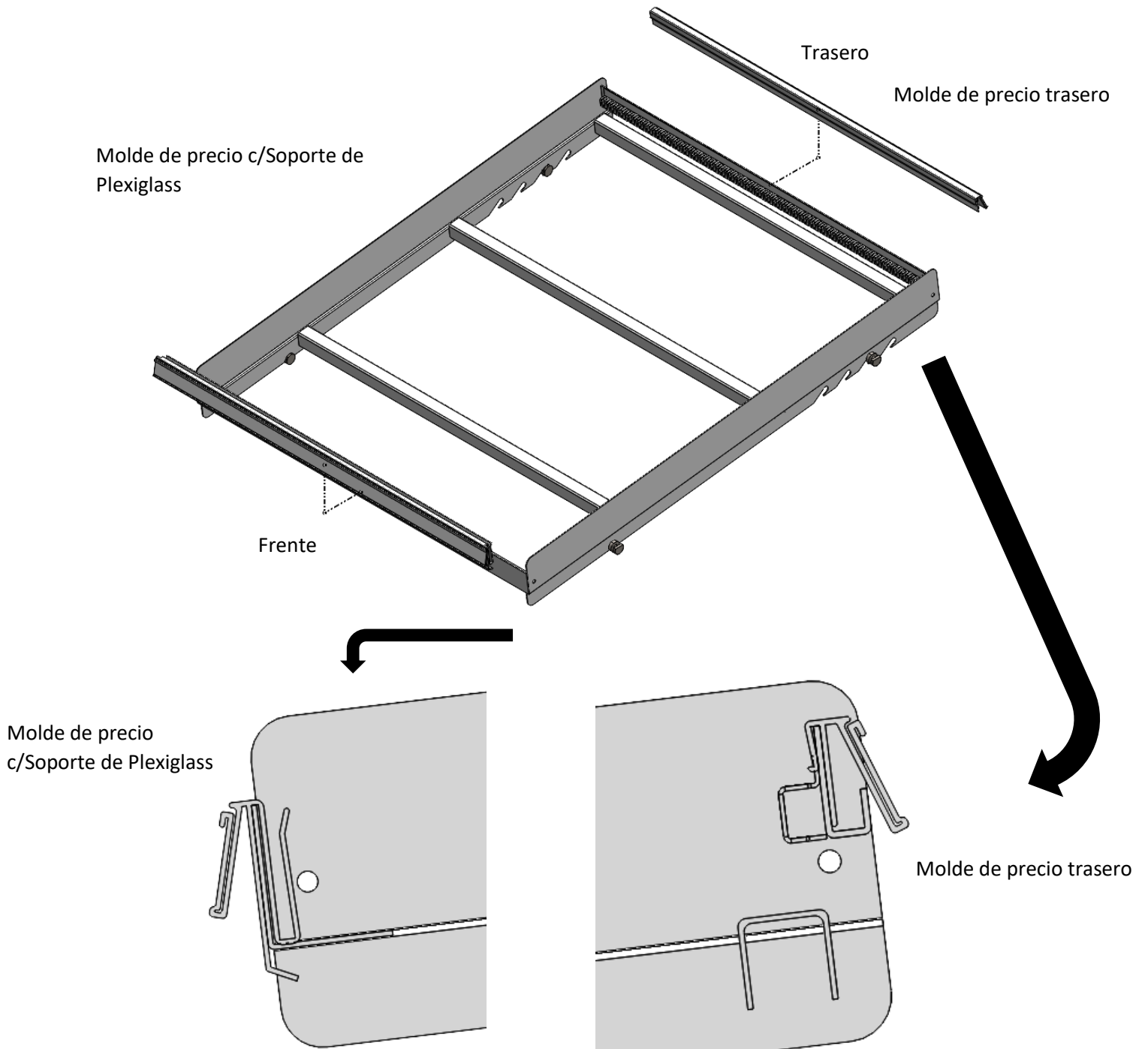



**Paso 8:** Coloque la cama de Cables en los estantes, luego, coloque encima dos Hojas plásticas en cada cama de cables.

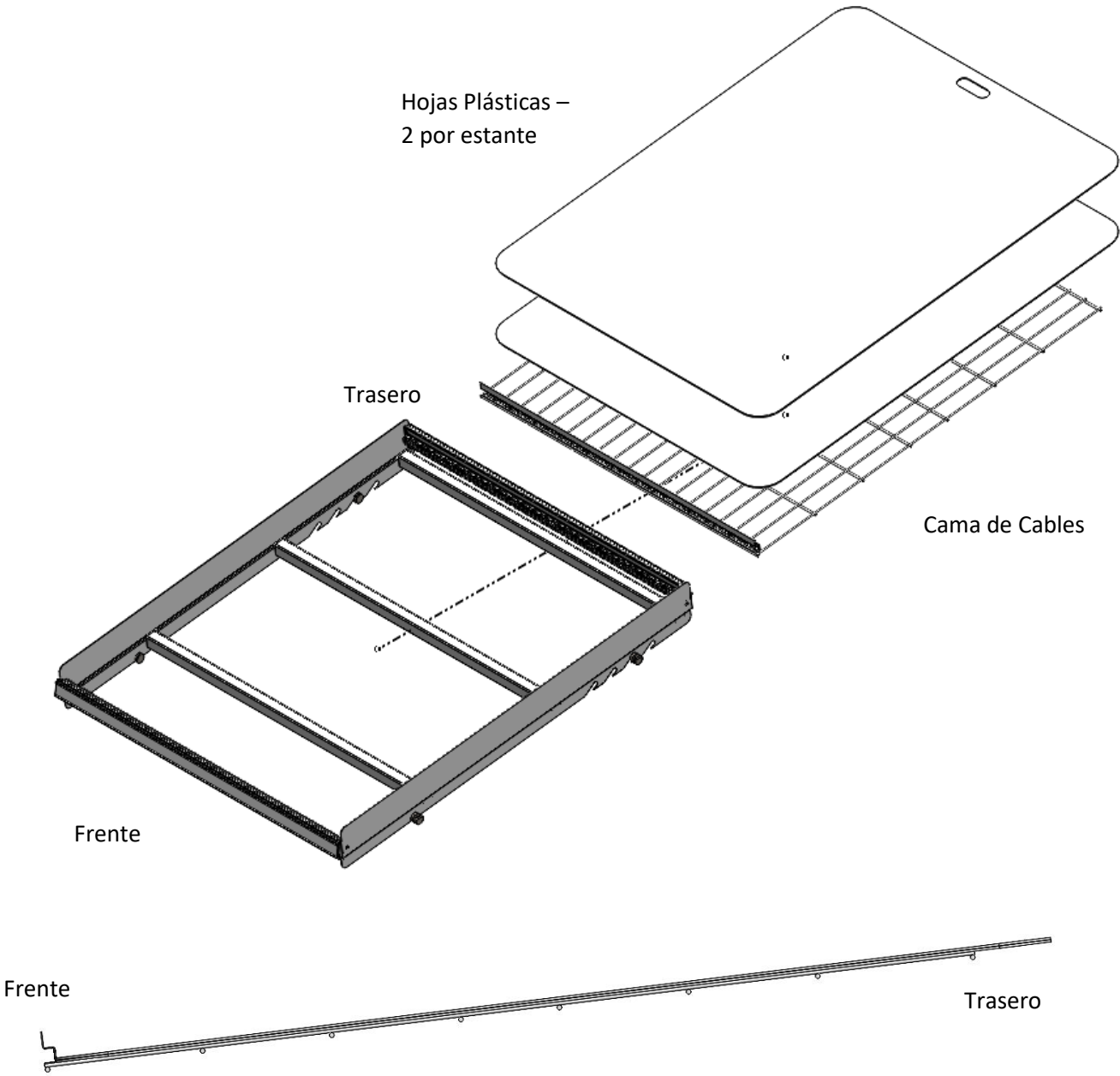

**Paso 9:** Instale cuantos divisores internos necesite en base al producto que será mostrado.

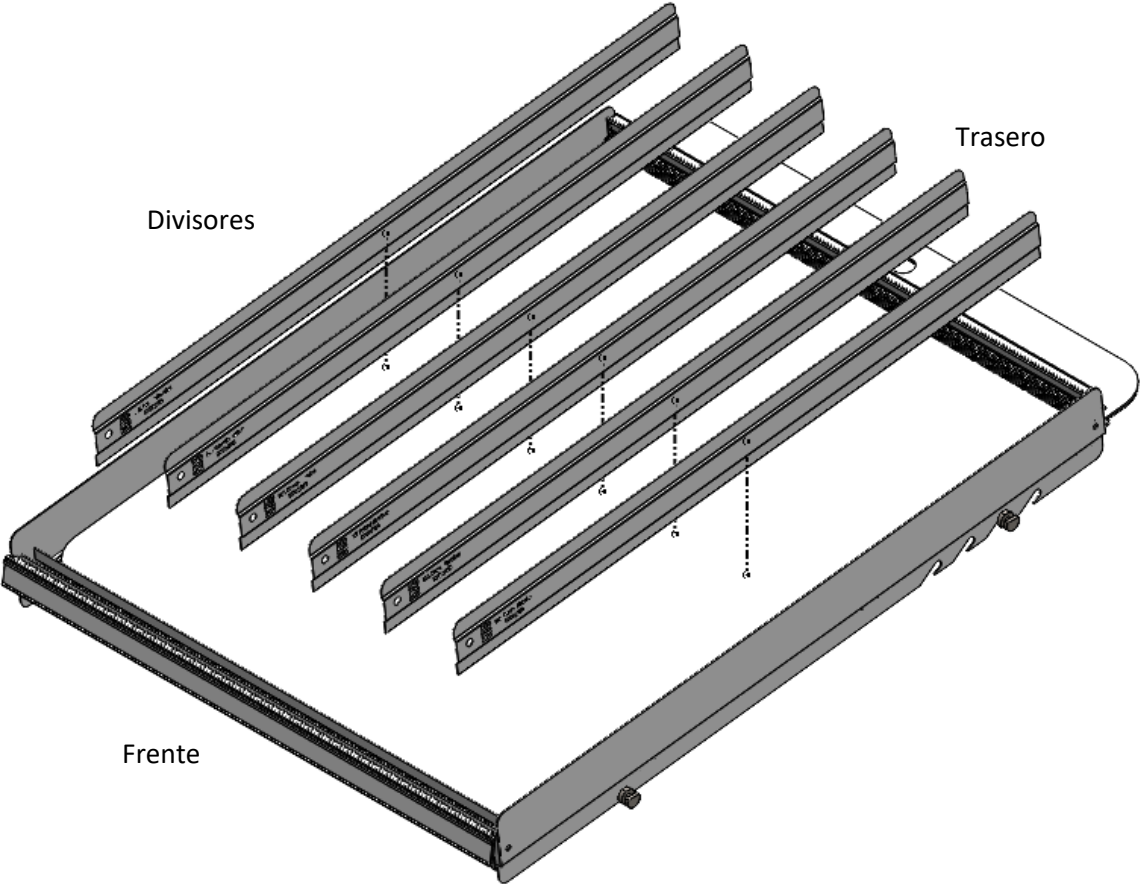

Los divisores deben estar asegurados en las guías, con la parte redonda hacia arriba y debe ir con el mismo lado en cada estante.

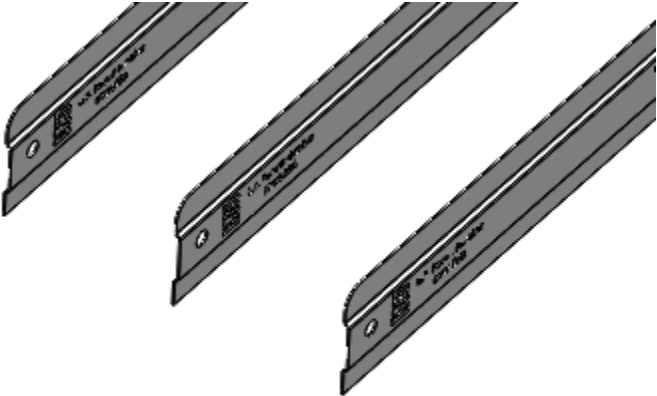

Colocando dos productos en cada línea es una manera útil de colocar los divisores.

**Paso 10:** Instale los Plexiglass de parada frontal dentro del molde de precio frontal c/Soporte de Plexiglass.

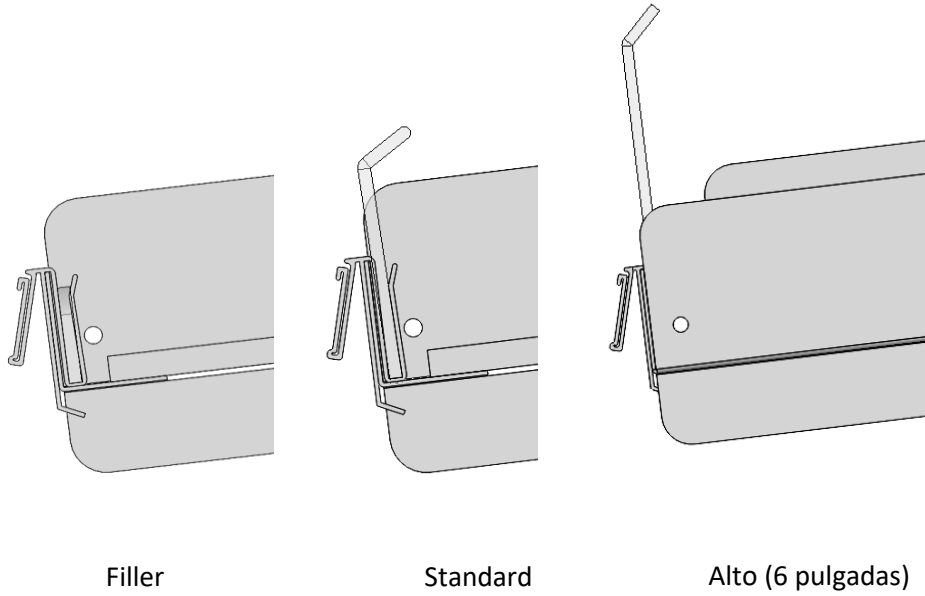
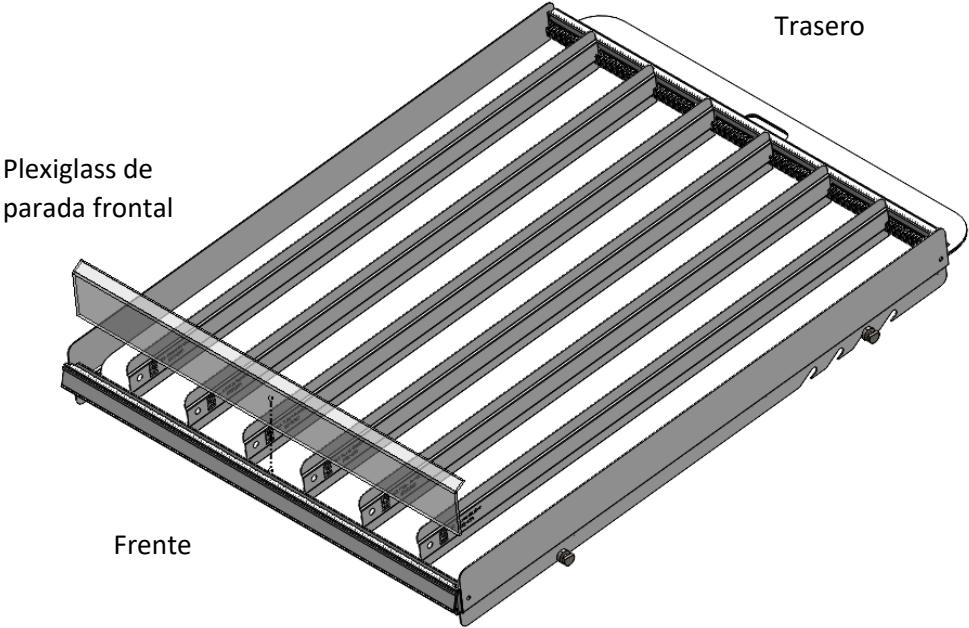

**Ensamblaje Completo:**

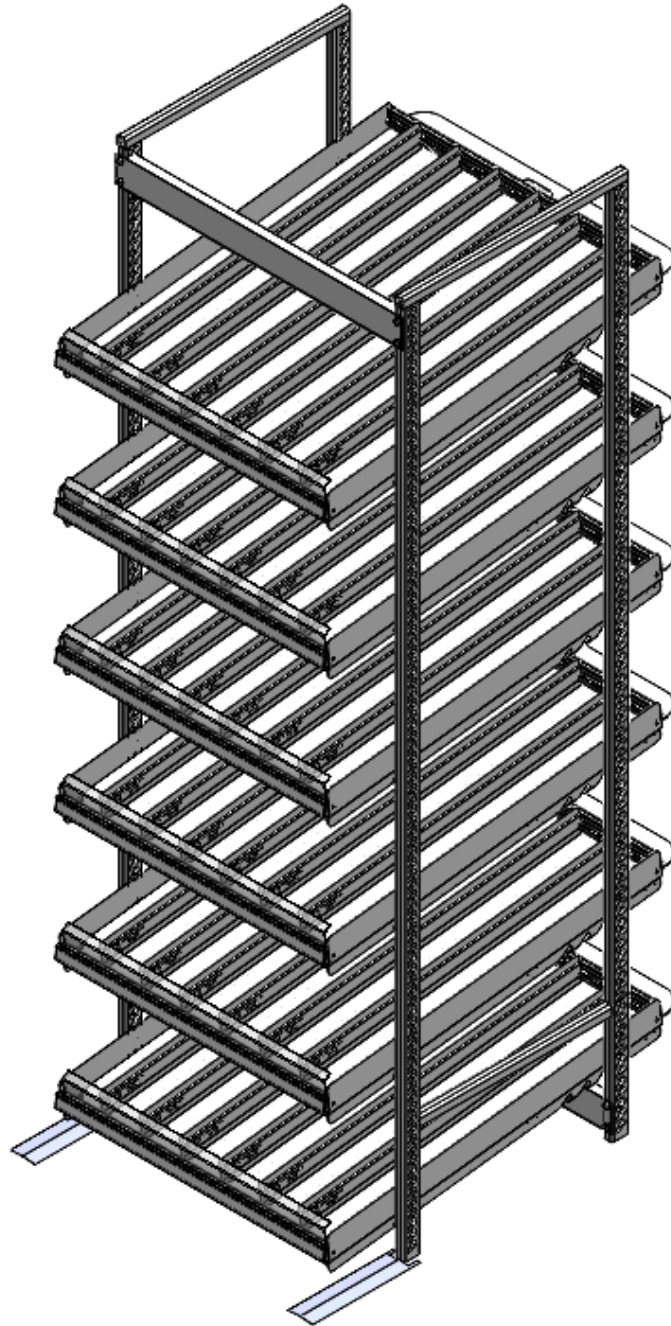

**¿Preguntas?**

**Llame al Servicio al Cliente...800-323-2517**