

# NYLA-TRACK II ASSEMBLY GUIDE



**Intertek**

Sanitation Listed  
Certified to NSF/ANSI 2 by Intertek

-Size of parts will differ depending on customer's order.

-Quantity of parts might differ depending on customer's order.

NEED:



Two people  
needed  
PARTS LIST



1/2" Wrench & Ratchet with  
1/2" Deep Well Socket



Level



Utility  
Gloves

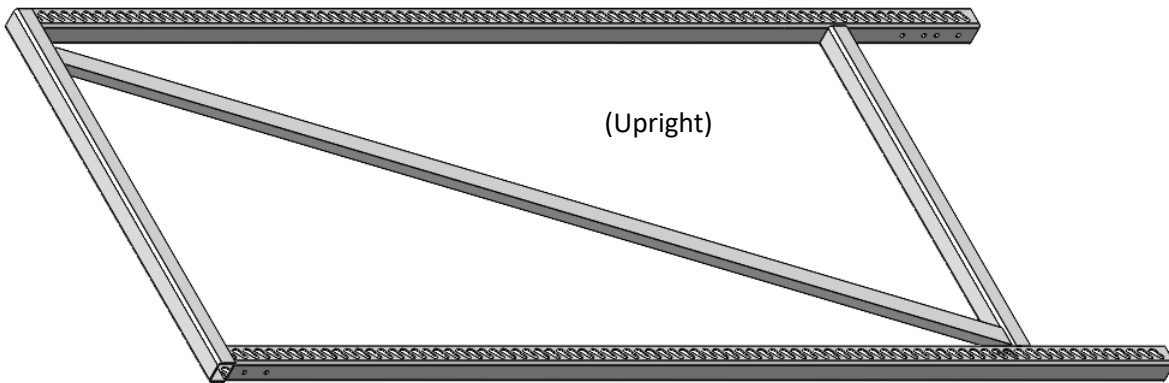

(7" Sway Brace - for Bottom)

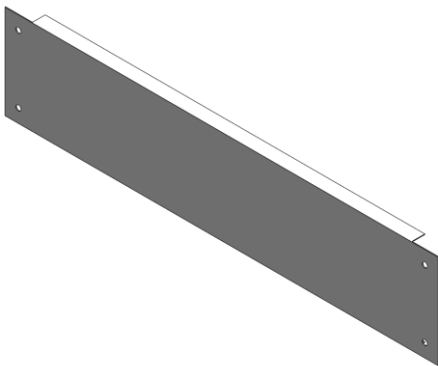

(3" Sway Brace - for top)

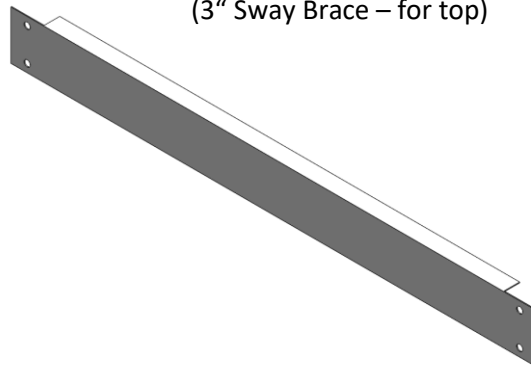

(Shelves)

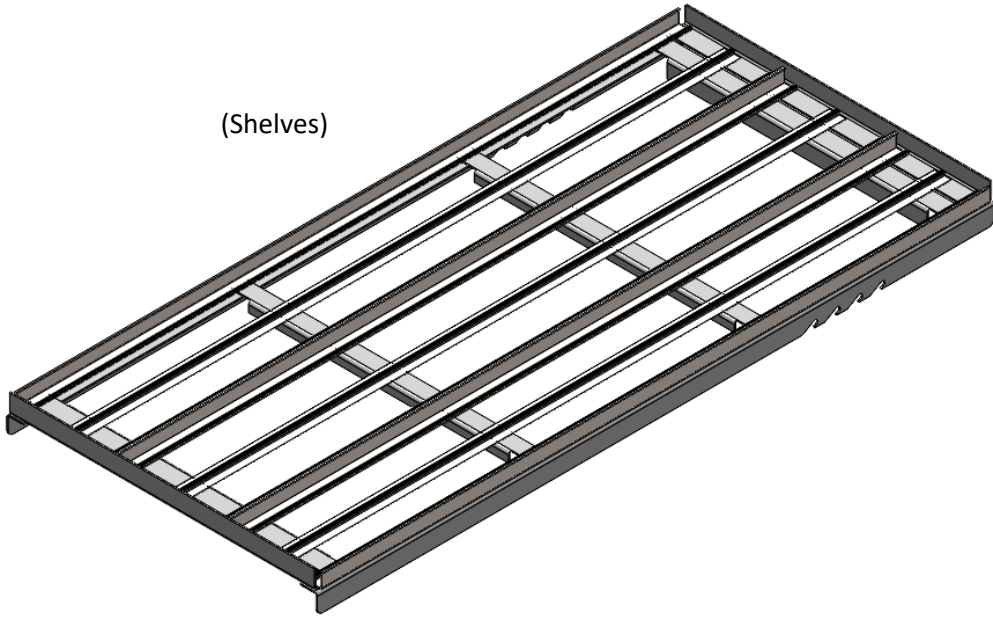

(Price Tag Molding w/Plexi Holder)

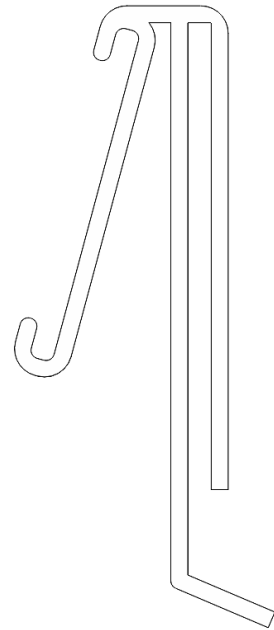
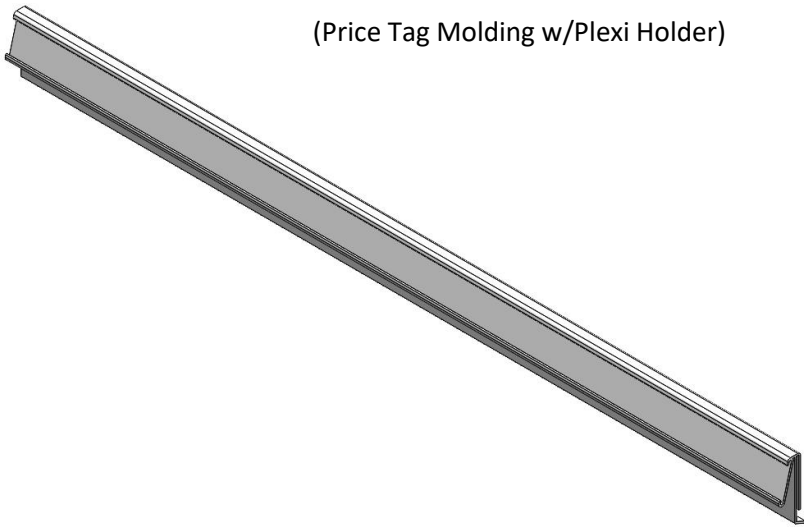

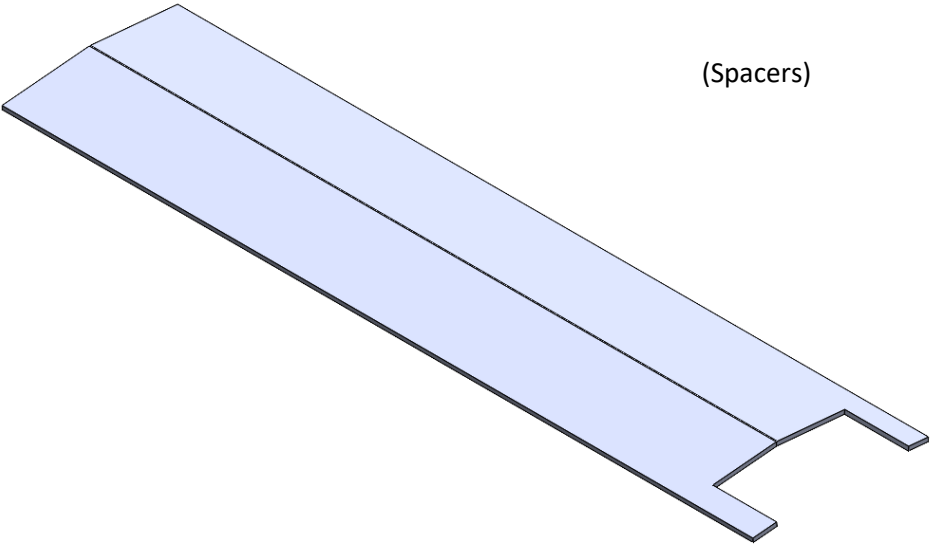

(Spacers)



Shelf Clamps

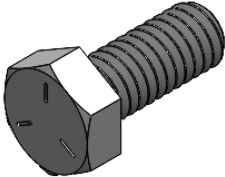

5/16" Bolt

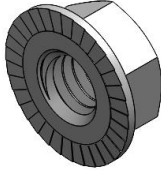

5/16" Nut

**Step 1: Tighten with fingers**, leave just finger tight until the end. Do **NOT** tighten with wrench until the end. Suggested location of sway braces are Top Front and Bottom Back. Each door will have installed Sway Braces of:

-(2) two x 3" tall sway braces.

**OR**

-(1) one 7" tall sway brace.

**If** the section is over 6' deep, each door section must have a total of 10" of sway braces.

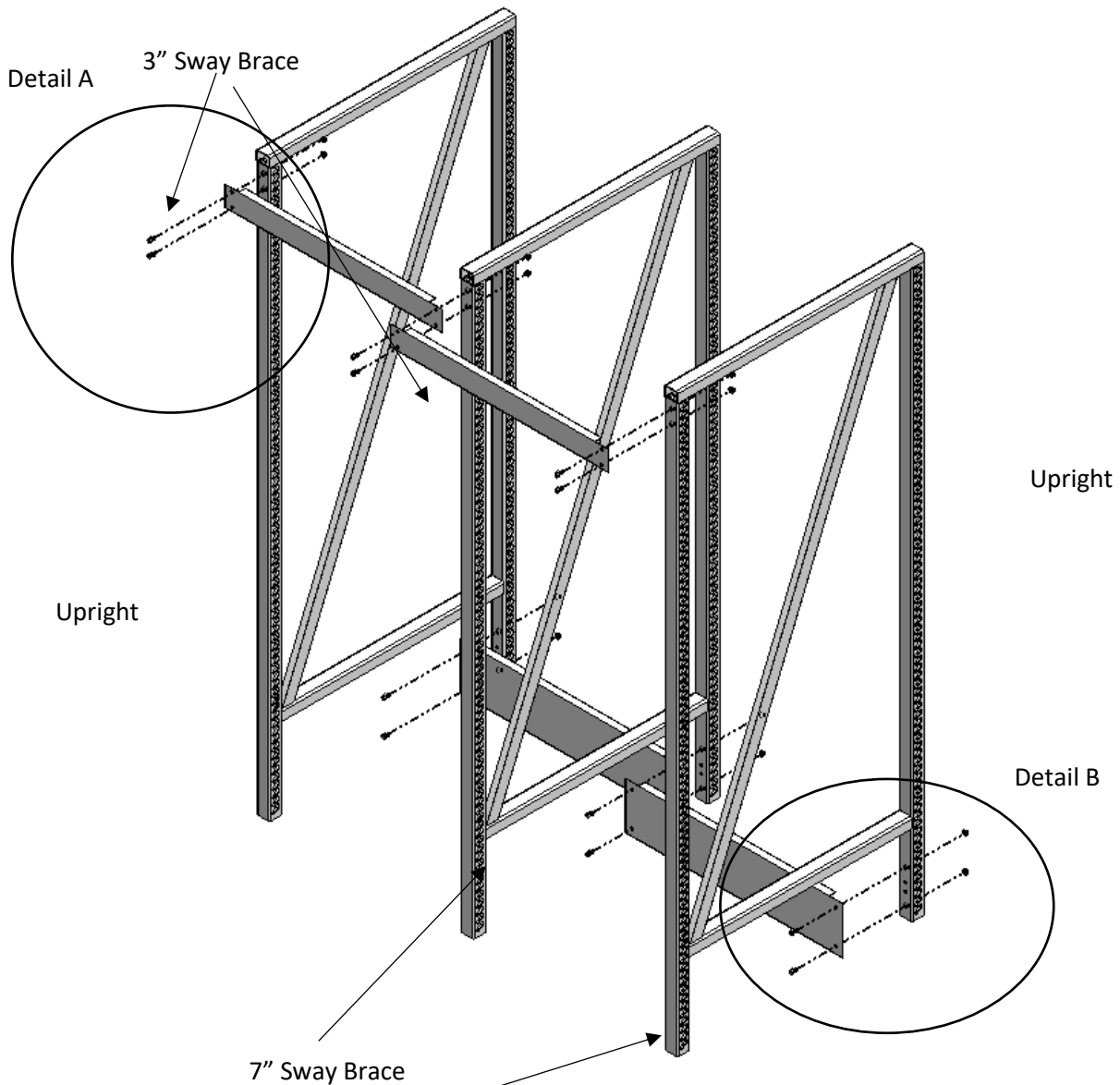

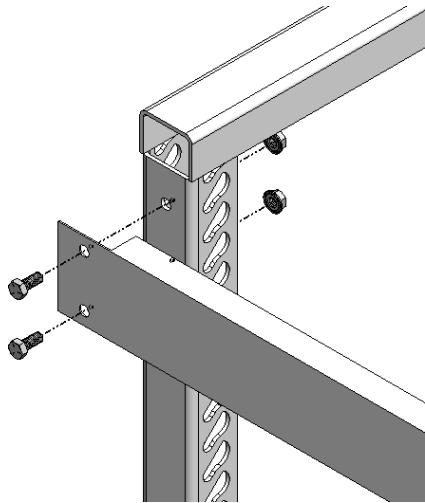

Detail A

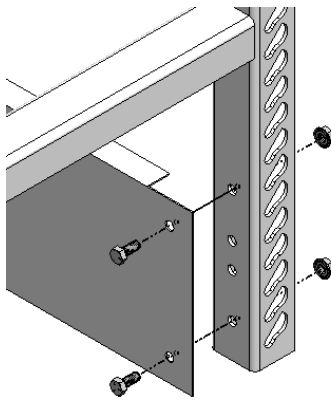
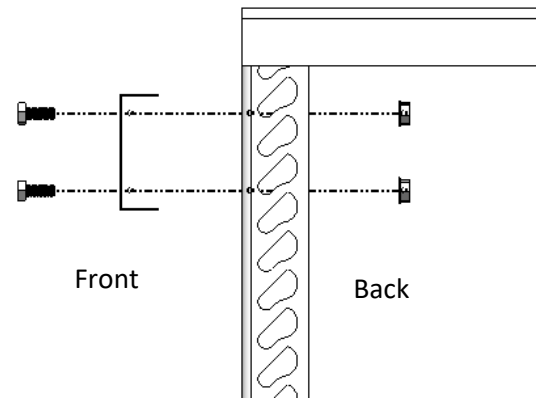

Detail B

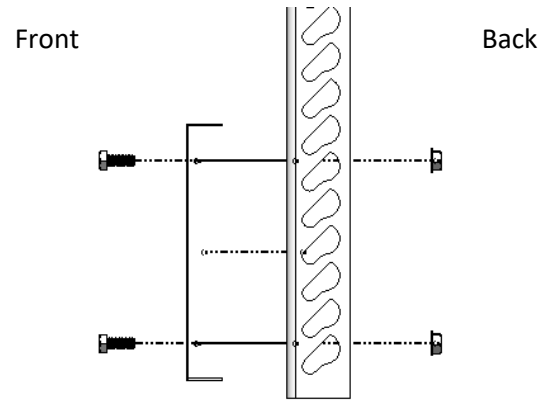

**Step 2:** Use spacers to set the clearance from the Frame to the door.

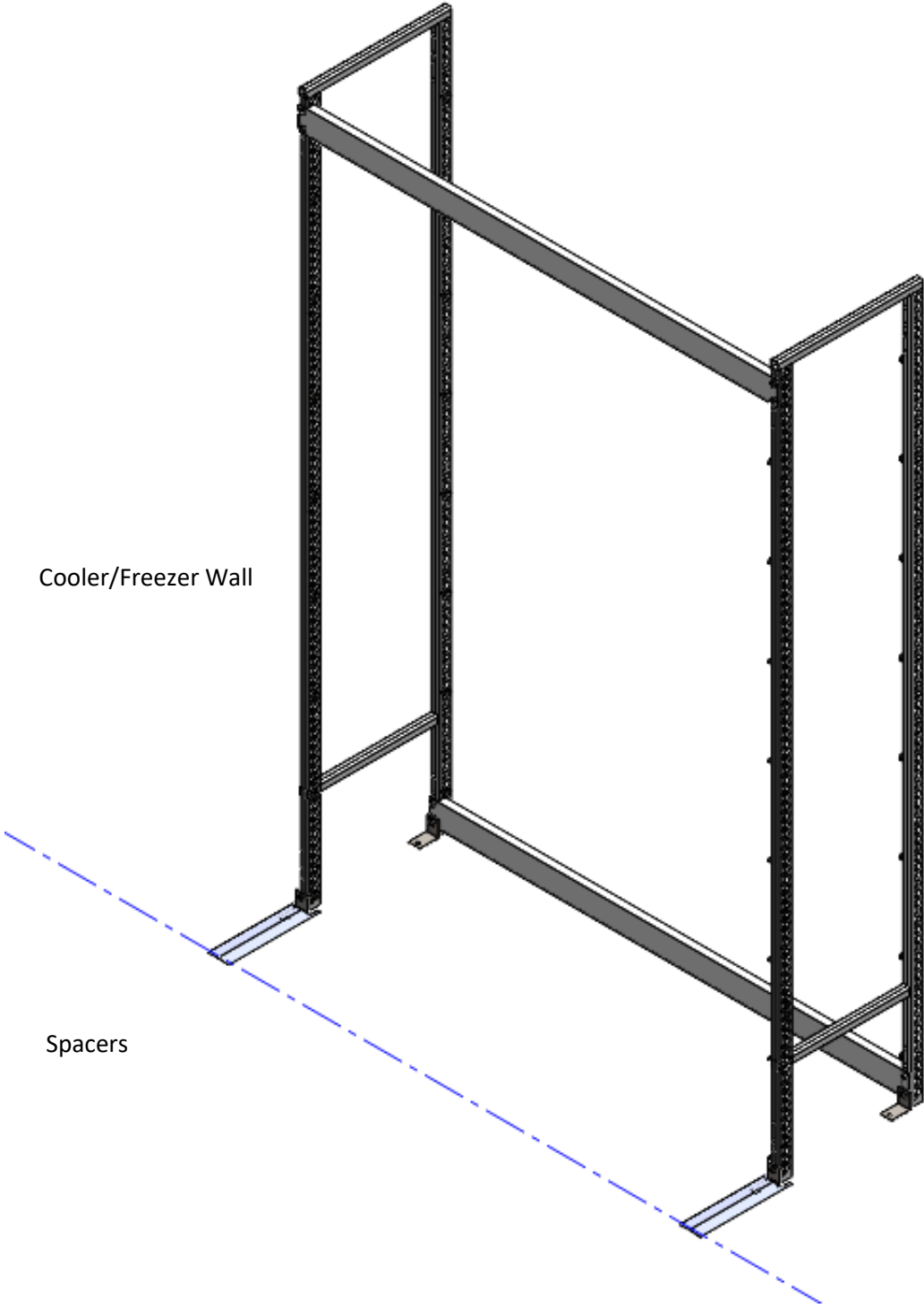

**Step 3:** Set Shelf clamps on the Upright frame to attach the Shelves.

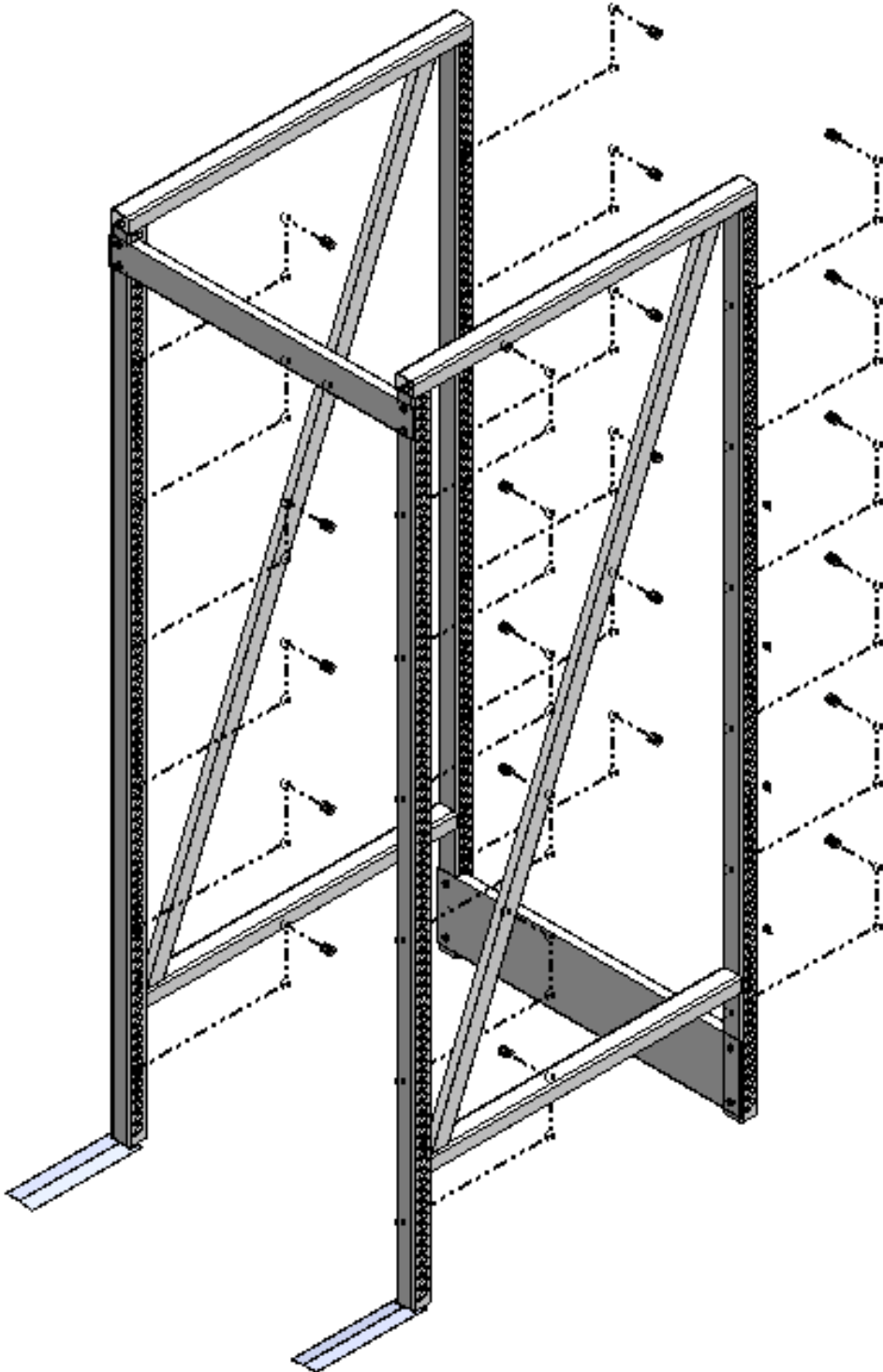



**Step 4:** Shelves comes in different variation for the Nyla Track II, however all of them, the dividers are pre adjusted and only requires to be installed on the frame with just one further action.

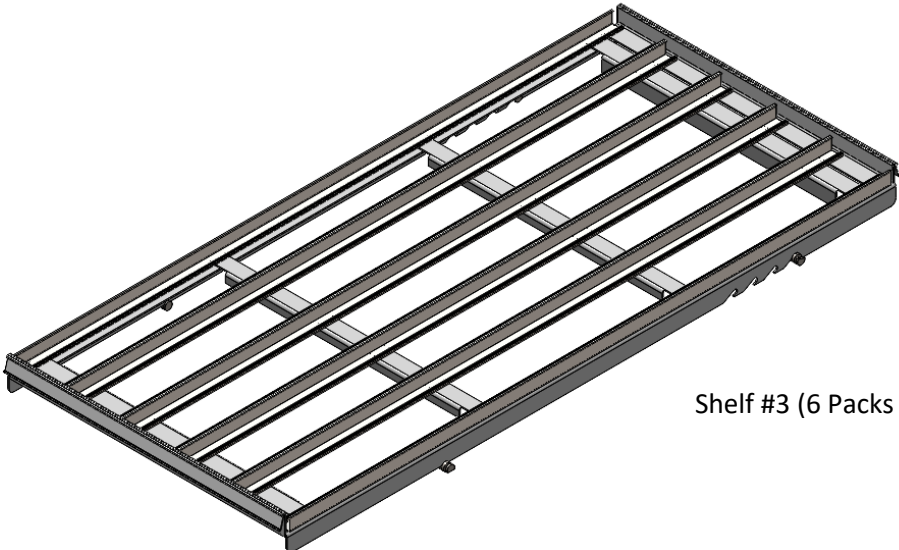

Shelf #3 (6 Packs – Narrow)

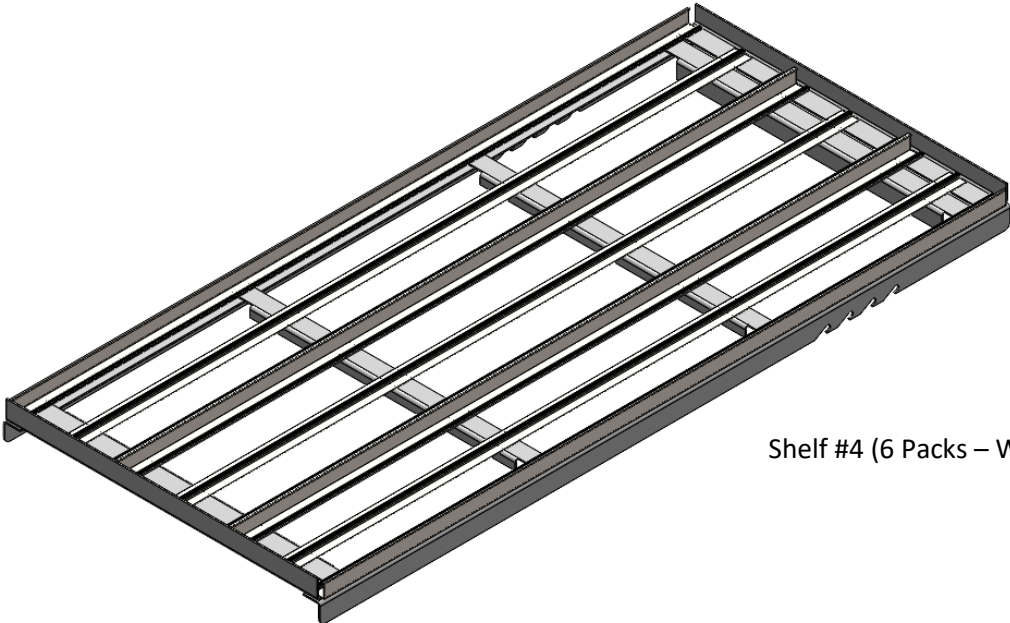

Shelf #4 (6 Packs – Wide)

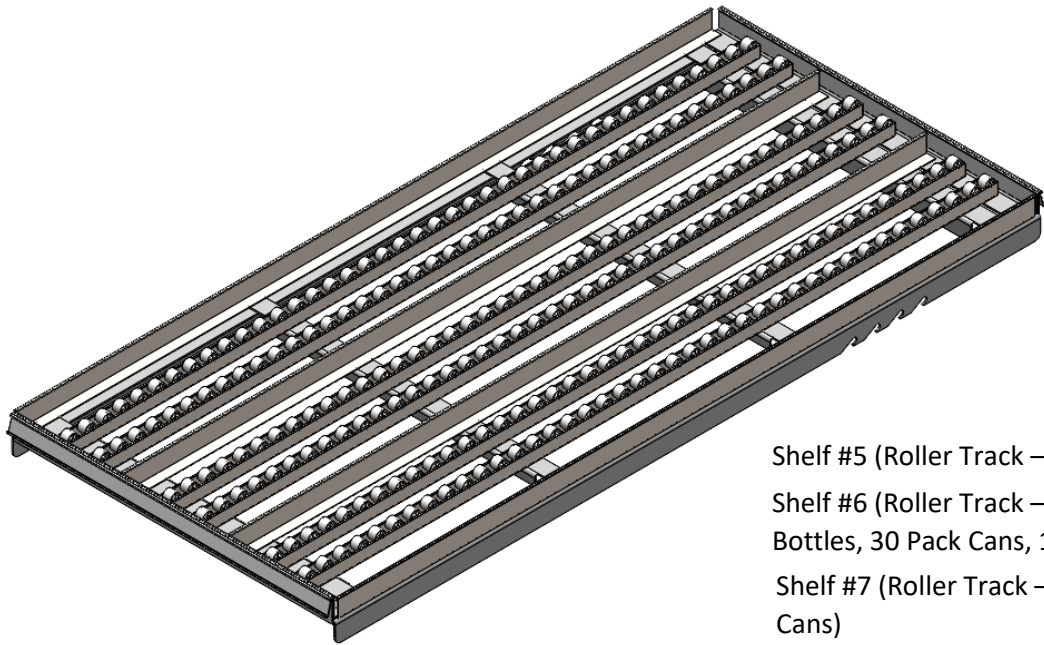

Shelf #5 (Roller Track – 24 Pack)

Shelf #6 (Roller Track – 9/12/18 Pack  
Bottles, 30 Pack Cans, 12 Pack Cans)

Shelf #7 (Roller Track – 12/18/24 Pack  
Cans)

Install top and bottom shelf frames **ONLY**. Use level to make sure rack is plumb.

Shelf Frames

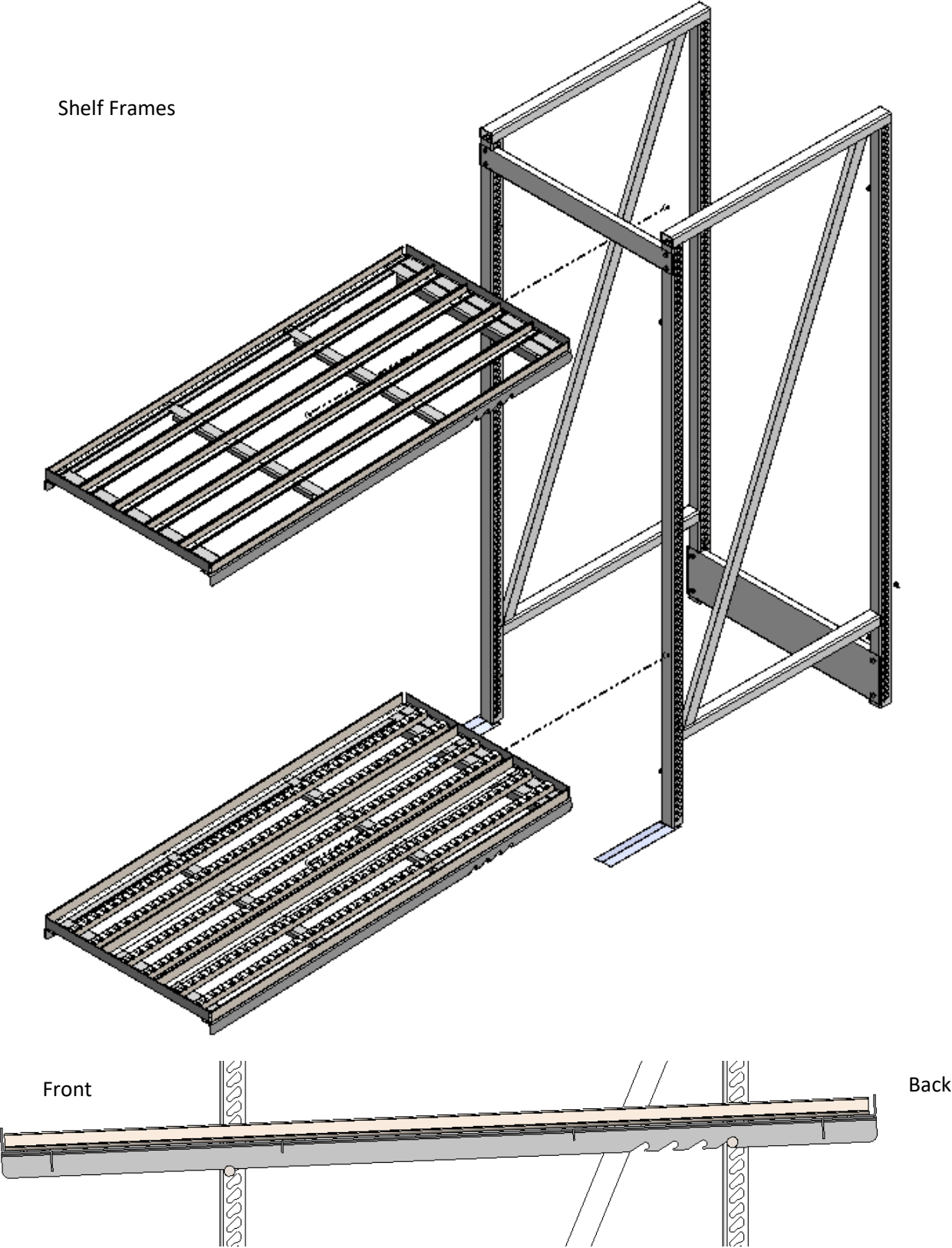

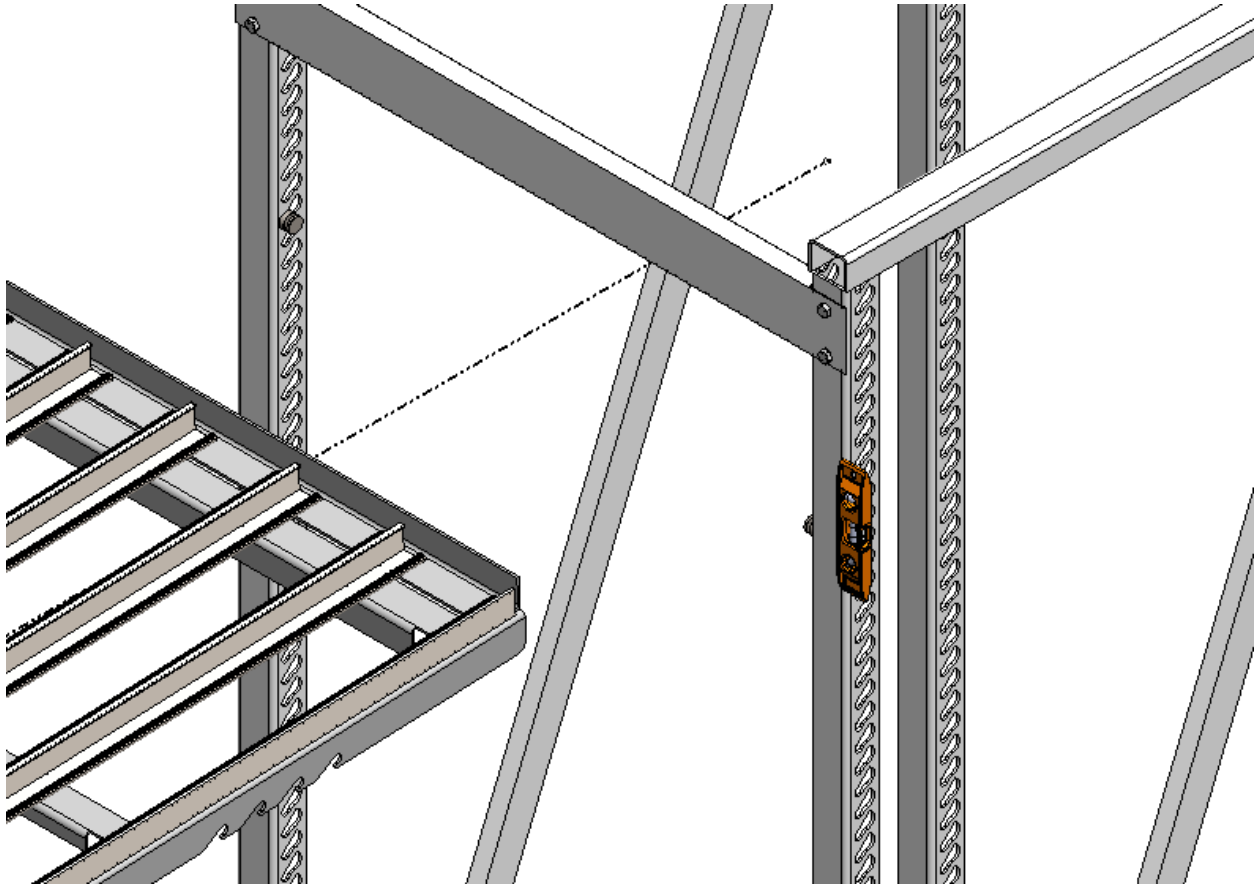

Step 5: **Tighten** all the bolts and nuts using the wrenches.

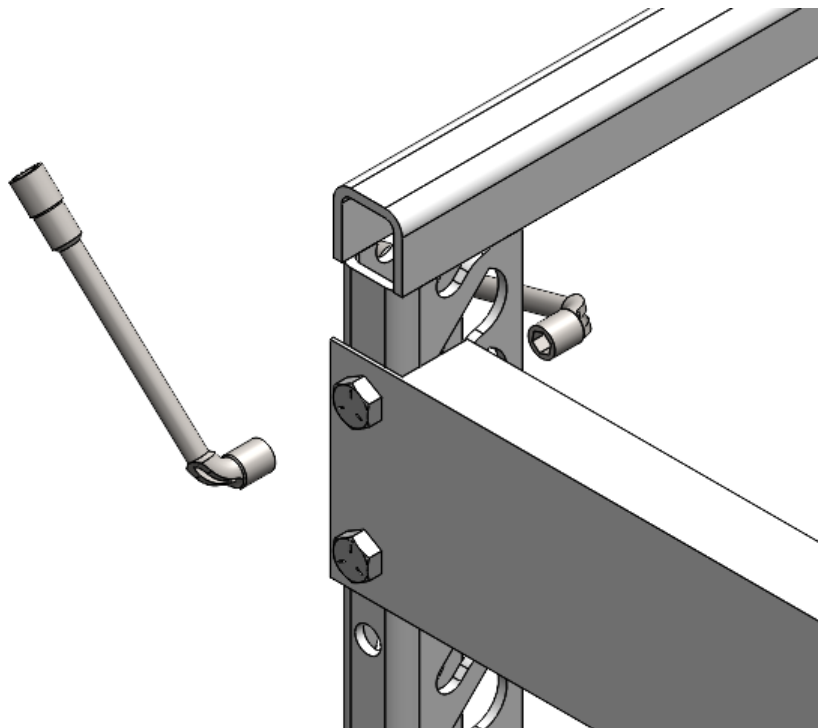

**Step 6:** Install remaining Shelf Frames.

Shelf Frames

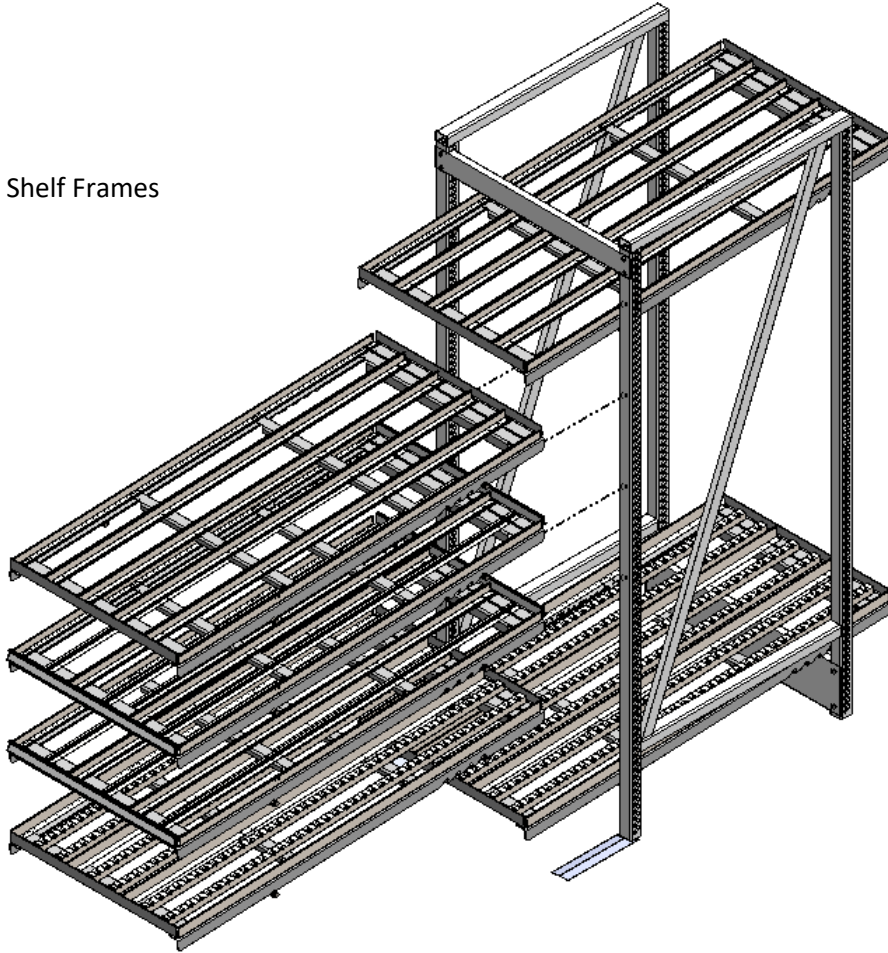

**Step 7:** If required to adjust the dividers for a different product, just need to loosen the wing nuts on the front and on the back of the shelf, adjust divider as desired and tighten again the wing nuts on the divider.

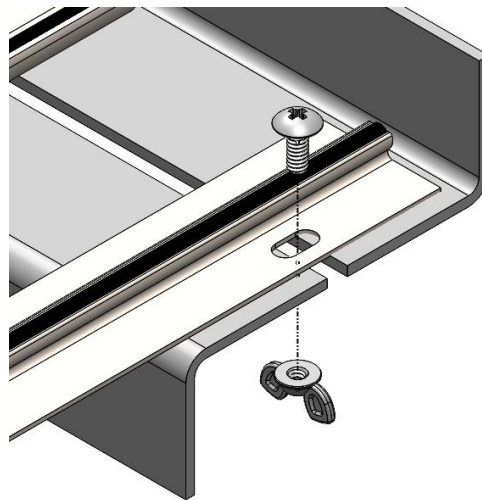

**Step 8:** Install Front/Rear Price Tag Molding.

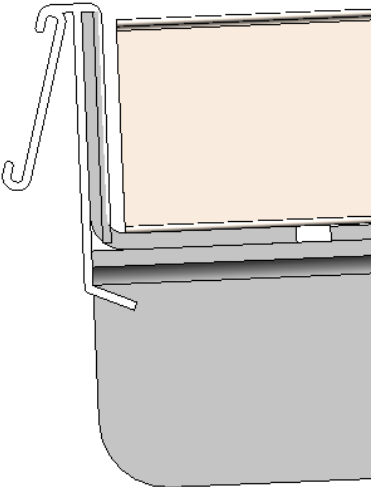
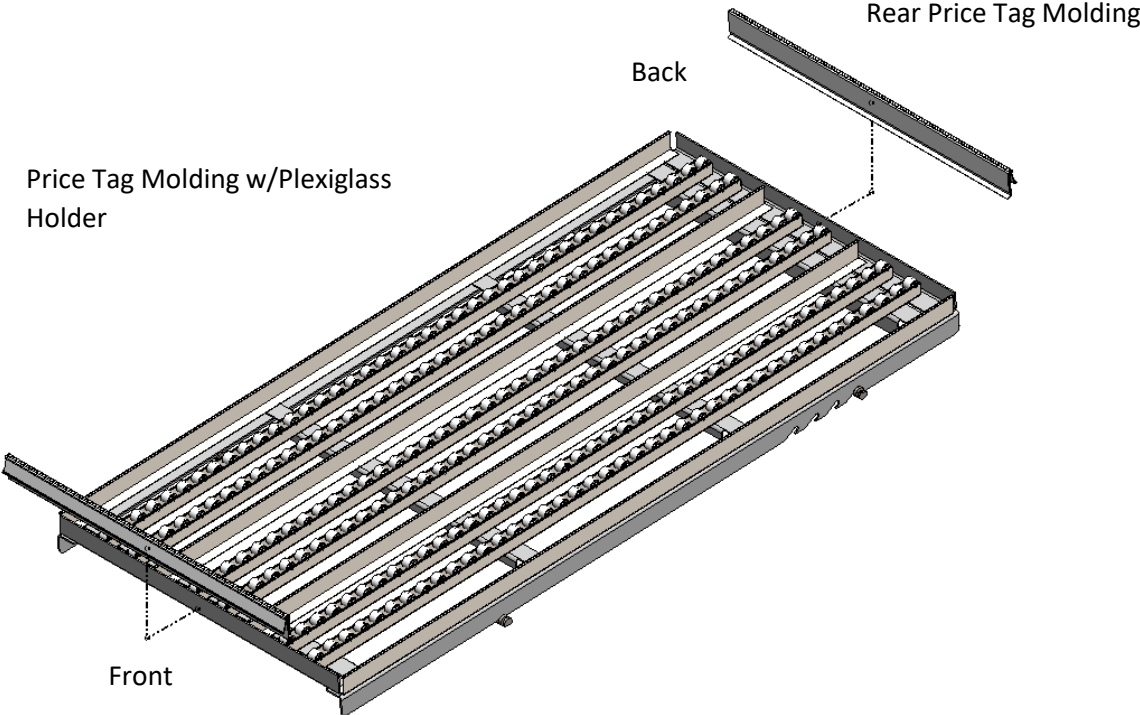



**Completed Assembly:**

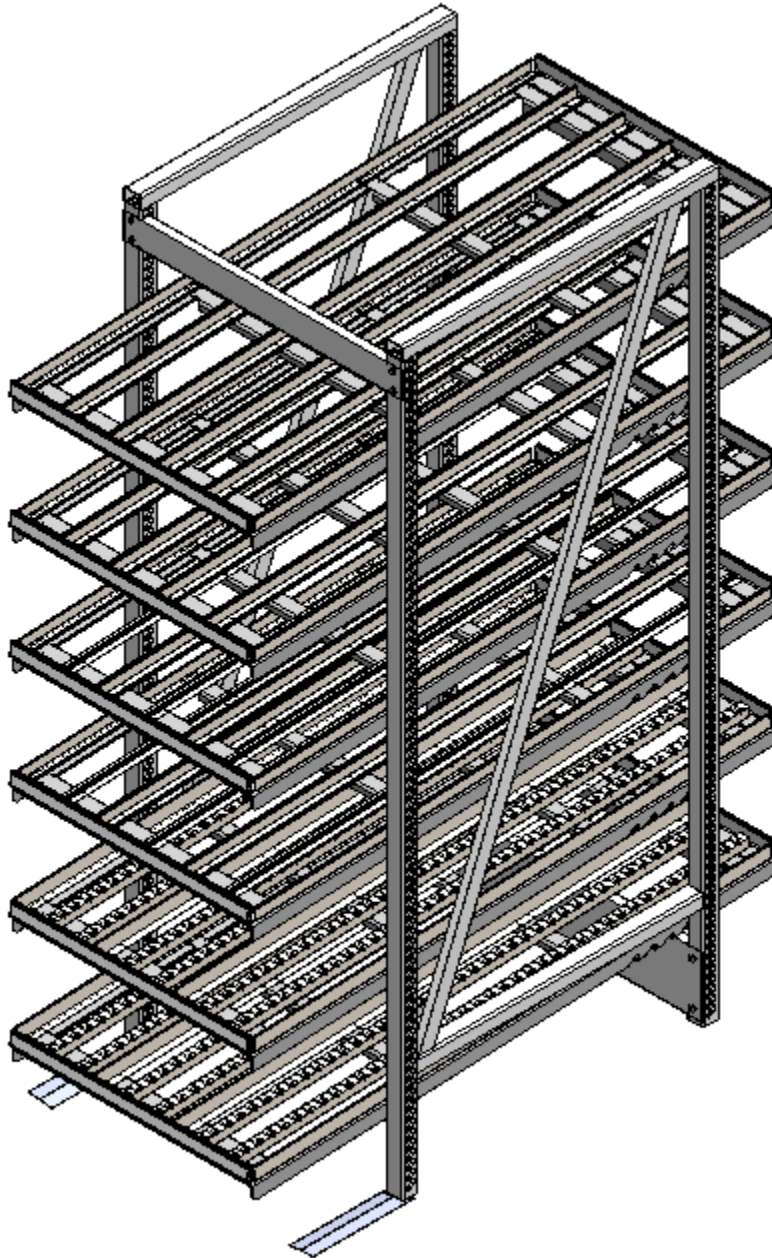

**Questions?**

**Call Customer Service...800-323-2517**