

VERSARACK + EZ CLEAN ASSEMBLY GUIDE



Intertek

Sanitation Listed
Certified to NSF/ANSI 2 by Intertek

-Size of parts will differ depending on customer's order.

-Quantity of parts might differ depending on customer's order.

NEED:



Two people
needed



1/2" Wrench & Ratchet with
1/2" Deep Well Socket



Level



Utility
Gloves

PARTS LIST

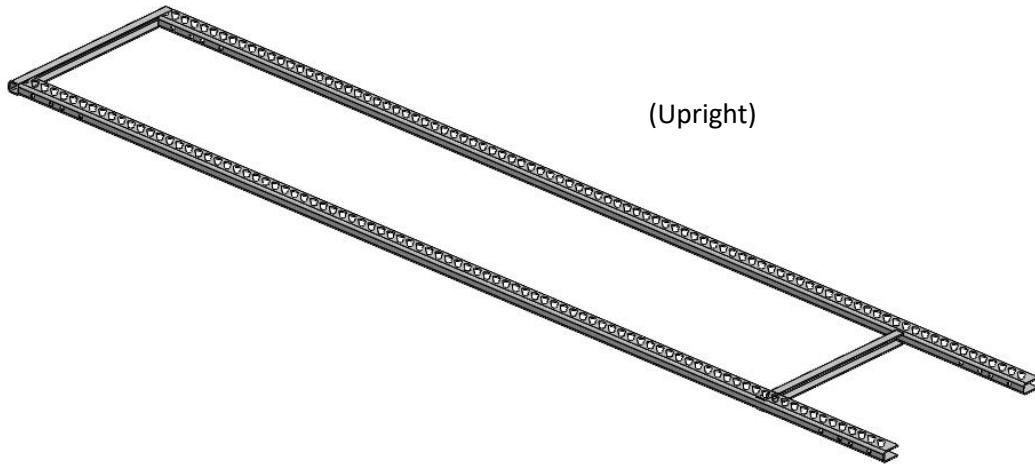

(Upright)

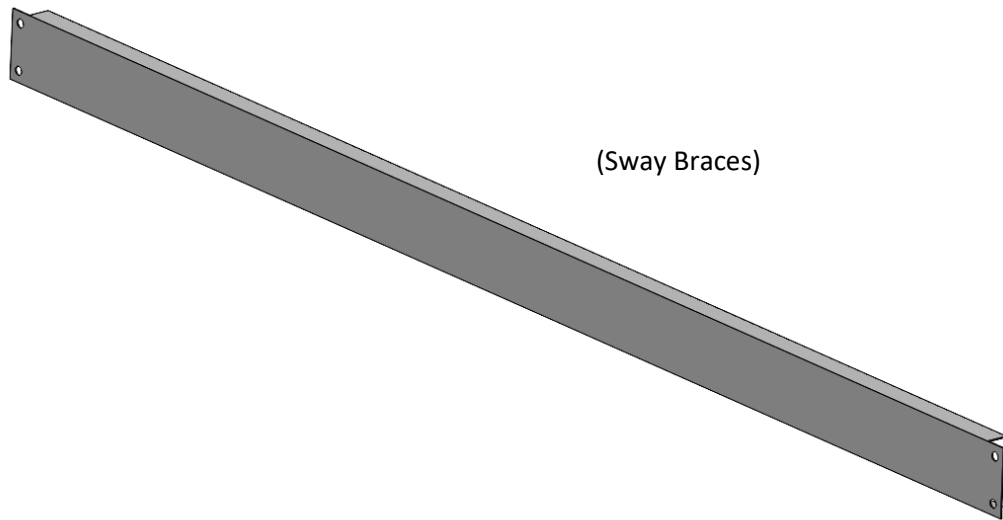

(Sway Braces)

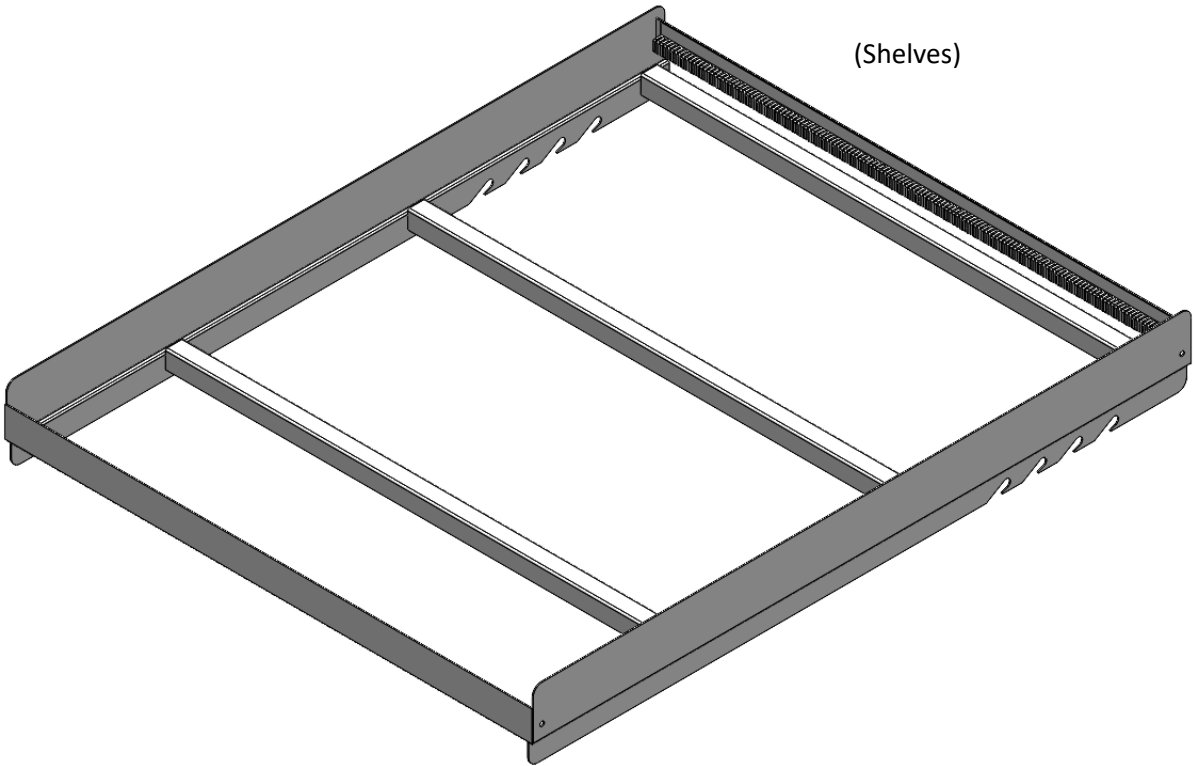

(Shelves)

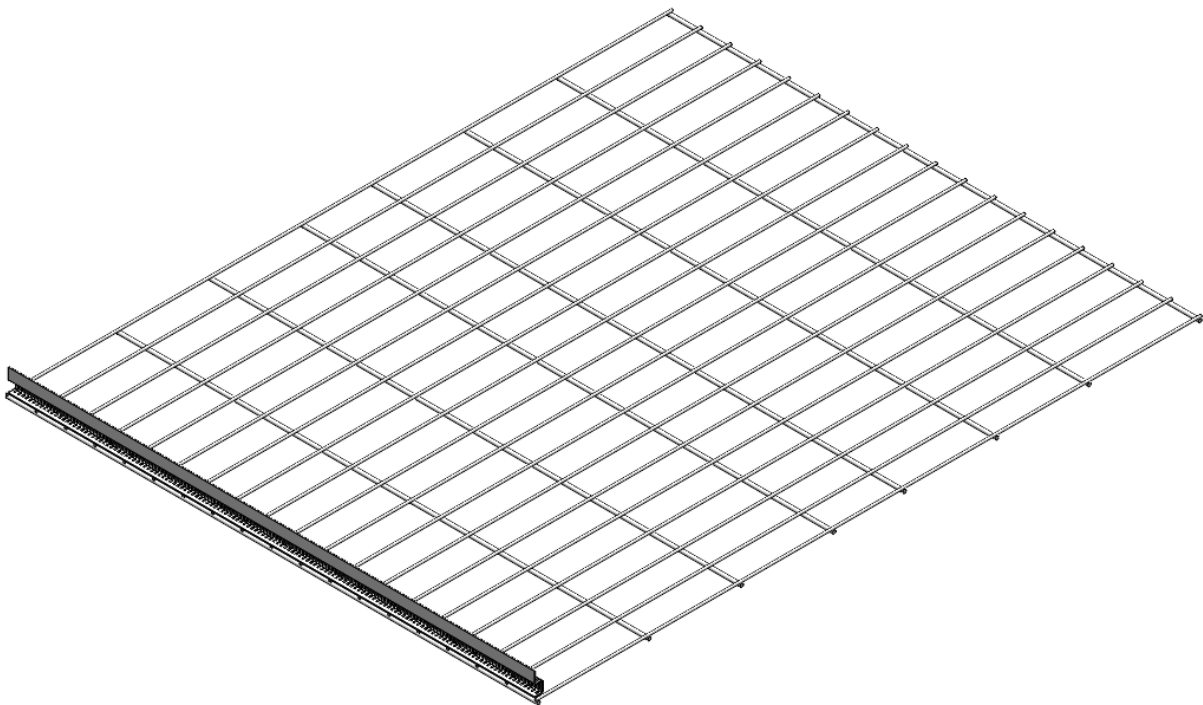

(Wire Mat)

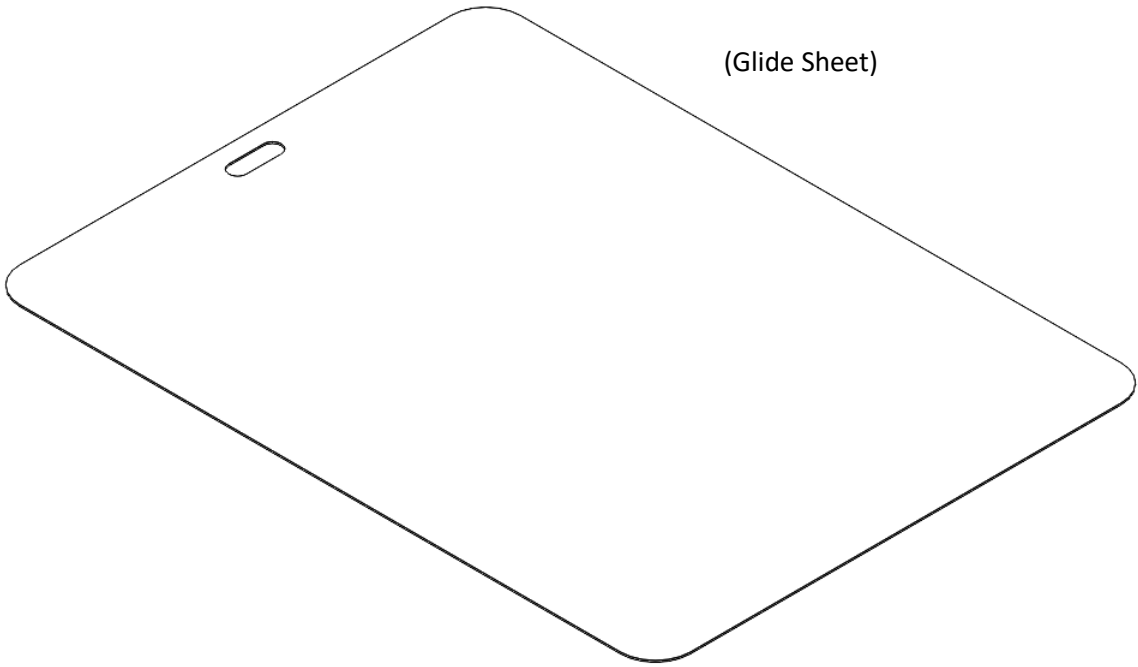

(Glide Sheet)

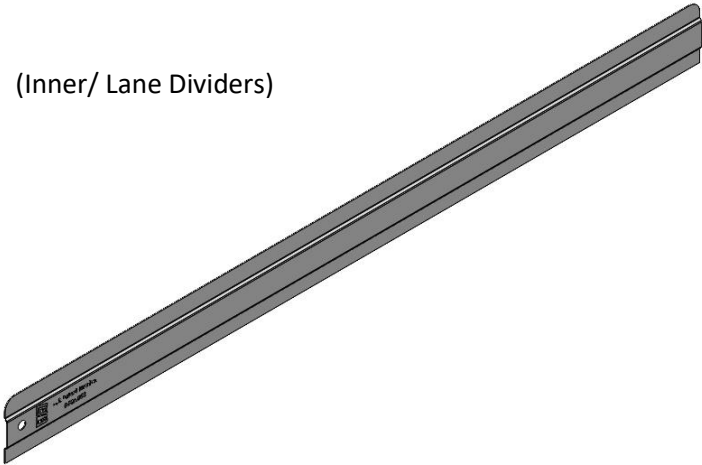

(Inner/ Lane Dividers)

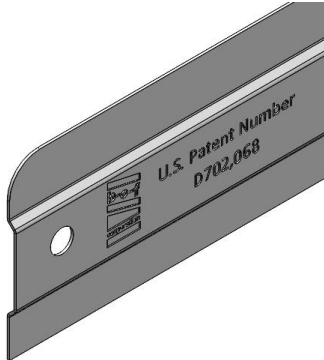

Rounded Side Up

(Front Price Tag Molding w/Plexi Holder)

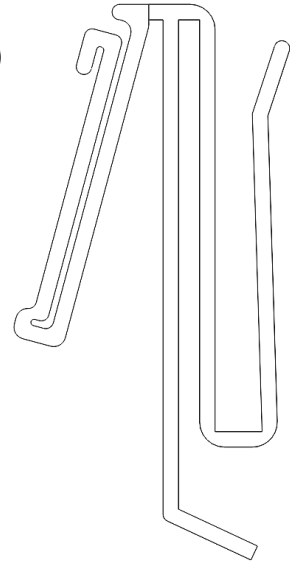
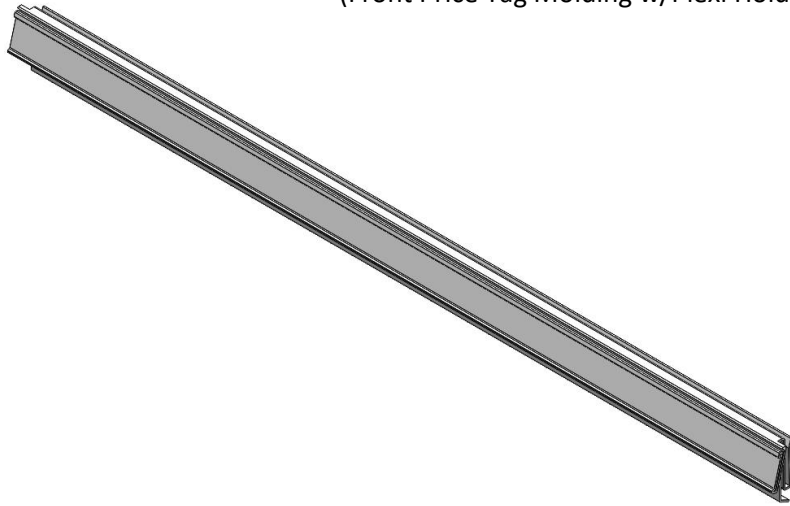

(Rear Price Tag Molding)

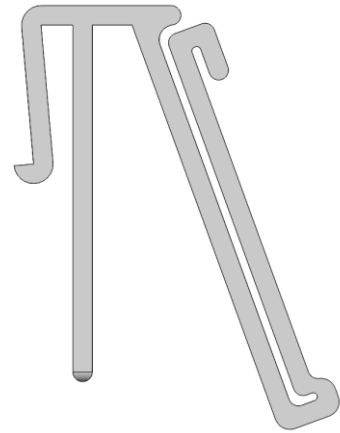
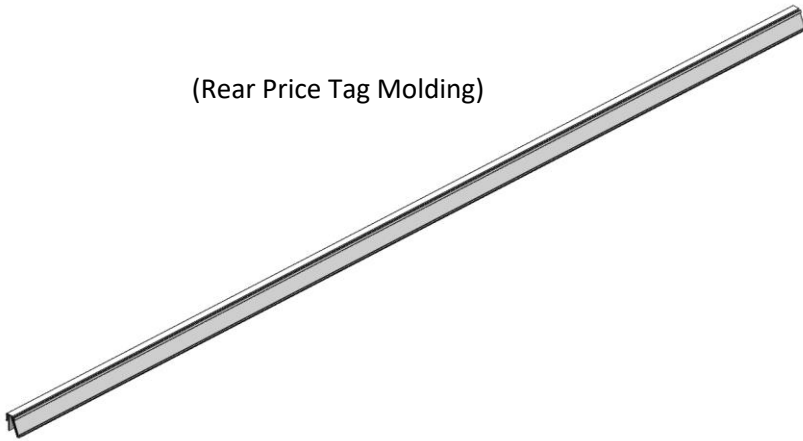

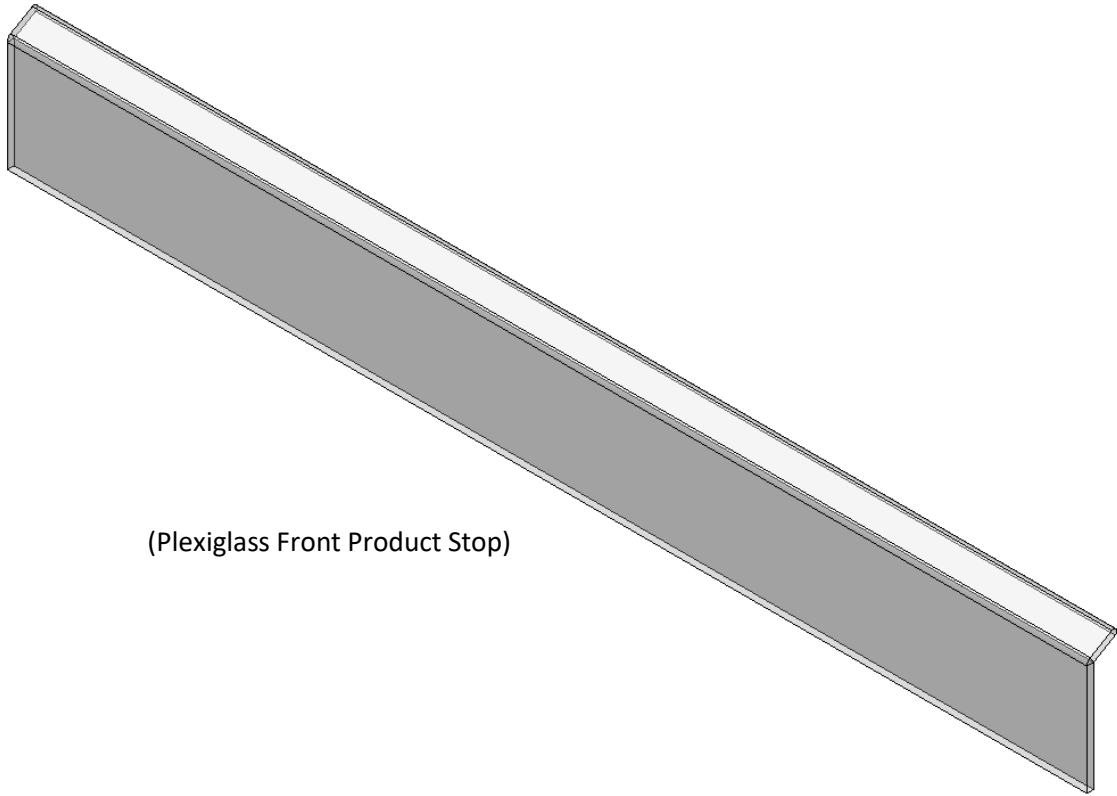

(Plexiglass Front Product Stop)

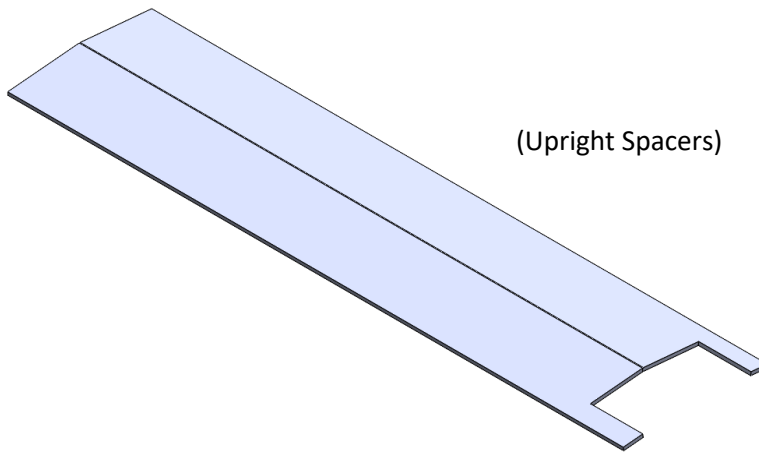

(Upright Spacers)



Shelf Clamps

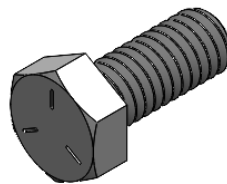

5/16" Bolt

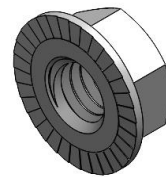

5/16" Wiz Nut

Step 1: Tighten with fingers, leave just finger tight until the end. Do **NOT** tighten with wrench until the end. Suggested location of sway braces are Top Front and Bottom Back. Each section must have 6 inches of sway brace.

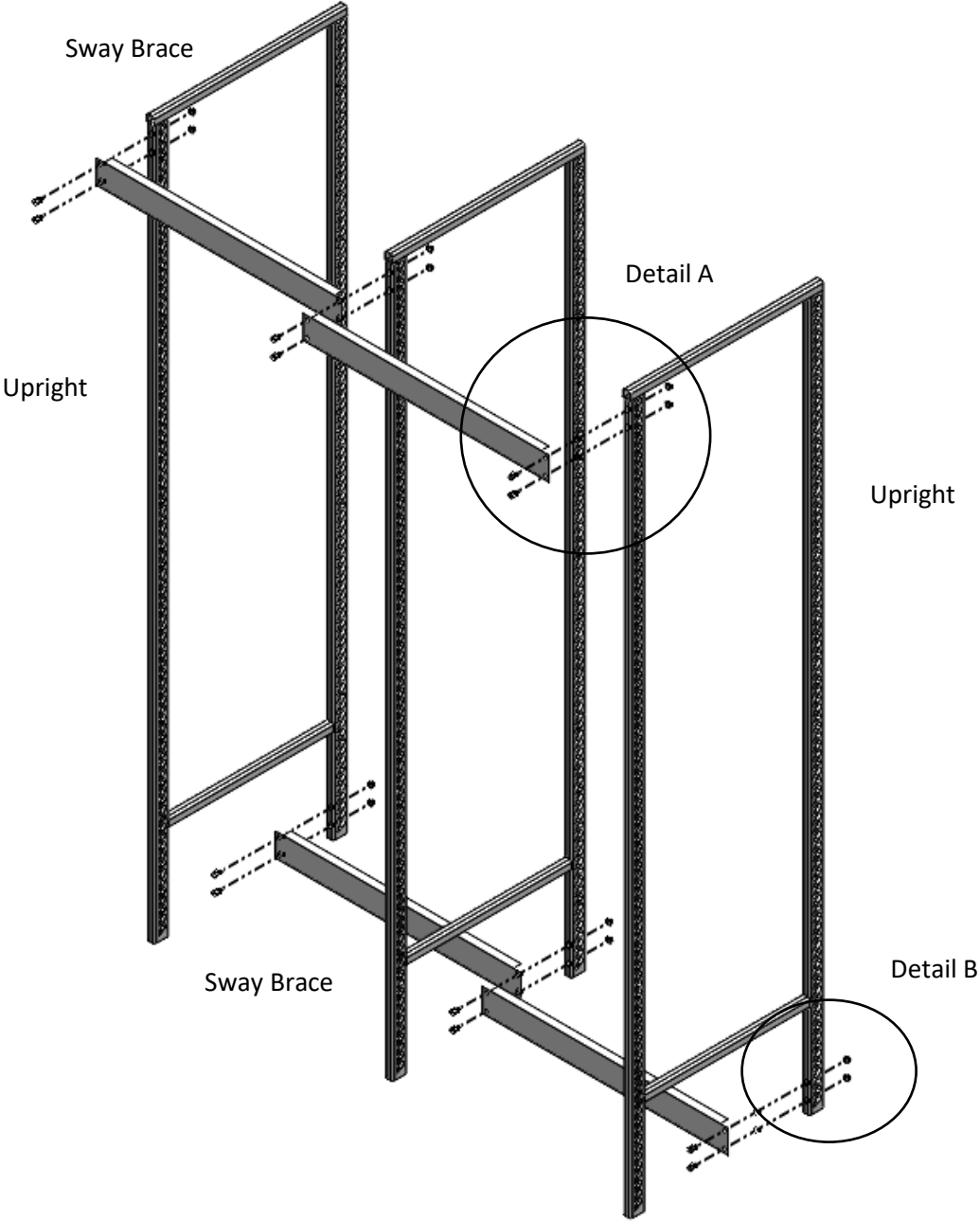

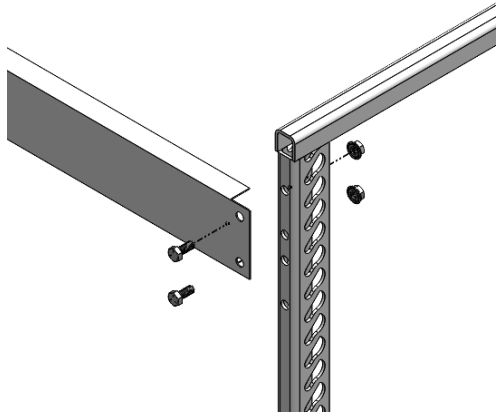

Detail A

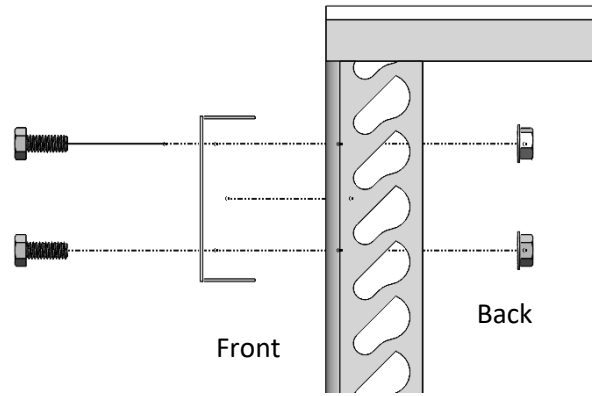

Sway Brace in the bottom will be attached using the 2 top holes.

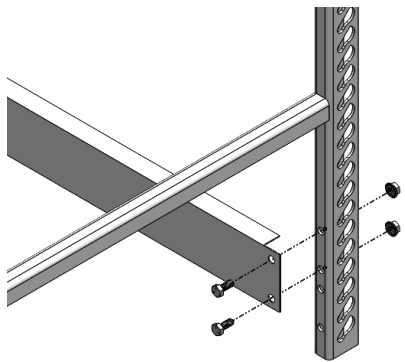

Detail B

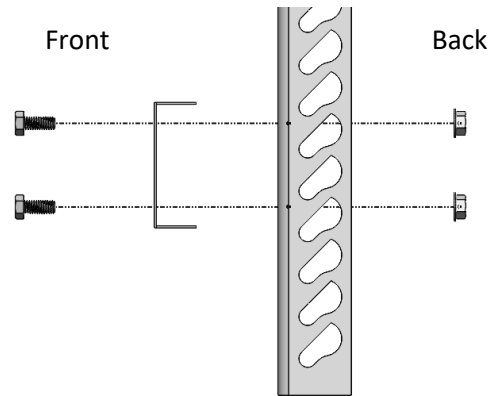

Step 2: Use spacers to set the clearance from the Frame to the door.

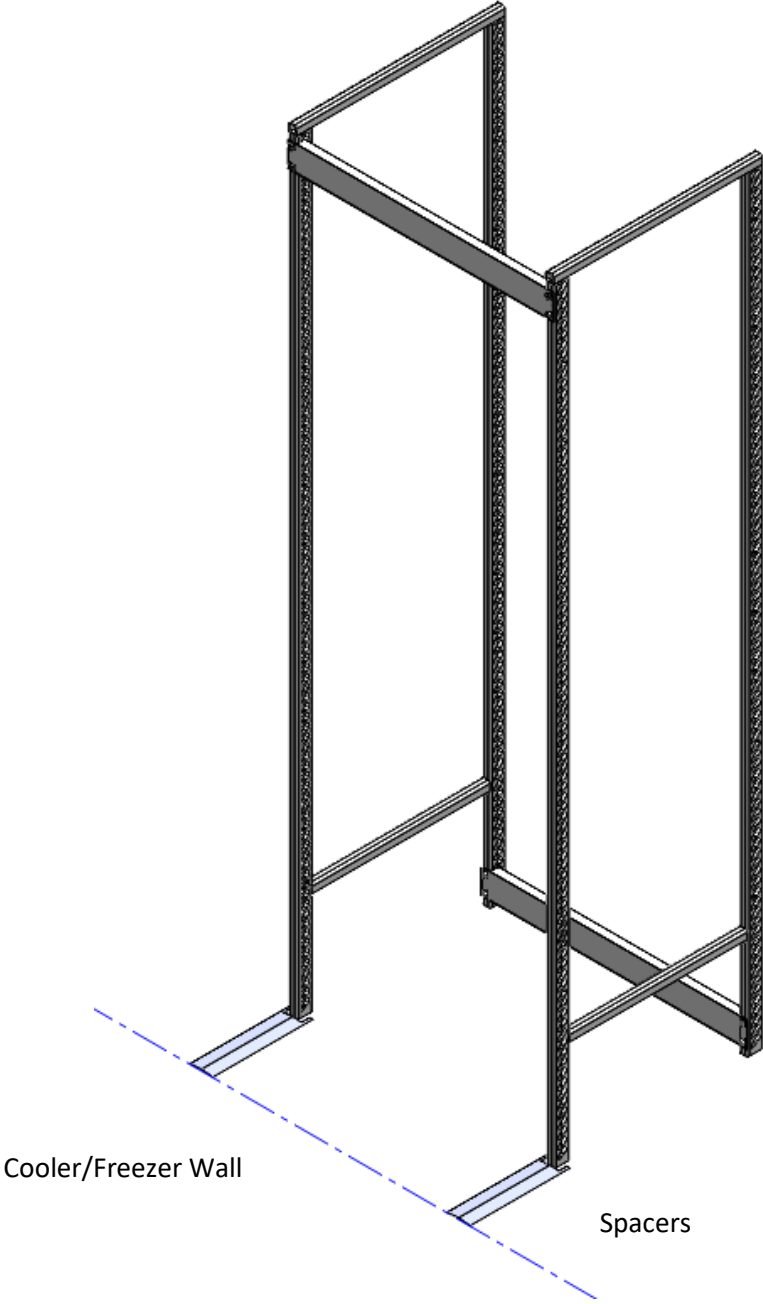

Step 3: Set Shelf clamps on the Upright frame to attach the Shelves.

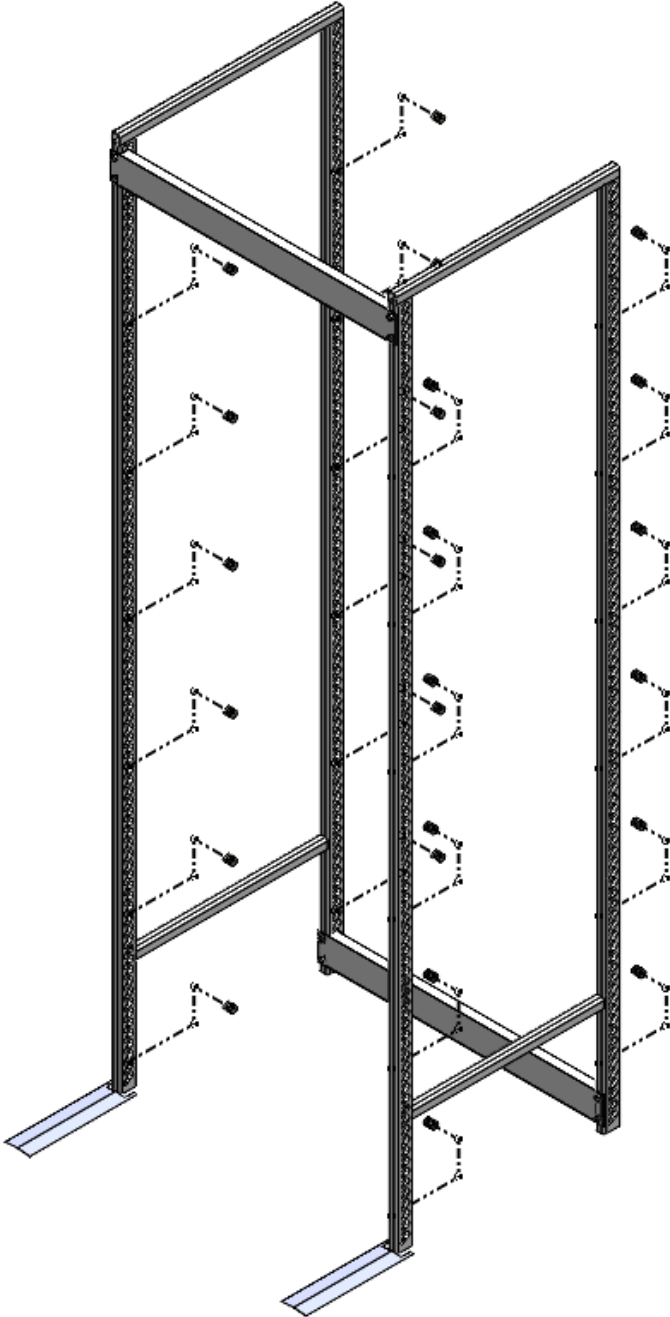

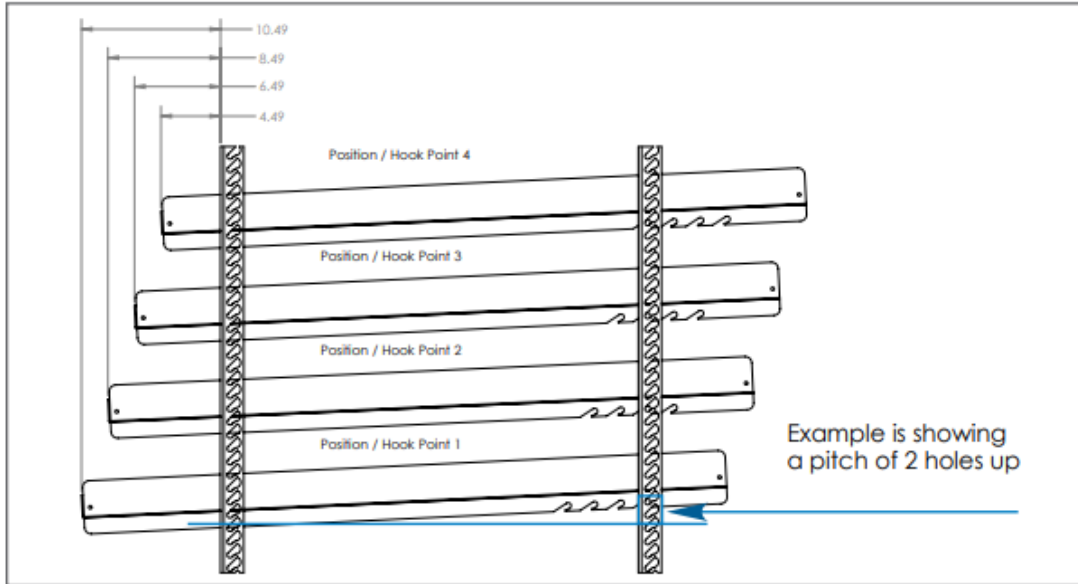

27" Shelf Depth

Product	Number of keyholes notches up
Plastic beverage	3
Carton beer	4
Cardboard water	4
Liquid dairy	3
Liquid dairy	4
Glass packaged	2

36" Shelf Depth

Product	Number of keyholes notches up
Plastic beverage	4
Carton beer	4
Cardboard water	4
Liquid dairy	4
Liquid dairy	4
Glass packaged	2

48" Shelf Depth

Product	Number of keyholes notches up
Plastic beverage	5
Carton beer	5
Cardboard water	5
Liquid dairy	5
Liquid dairy	5
Glass packaged	3

Step 4: Install top and bottom shelf frames **ONLY**. Use level to make sure rack is plumb.

Shelf Frames

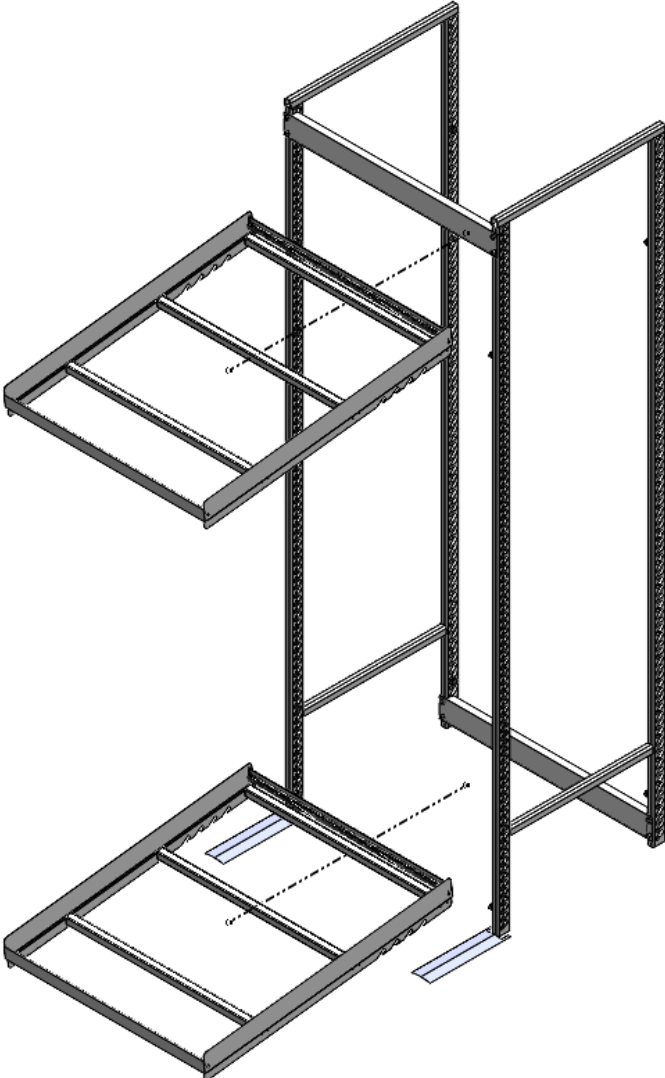

Front

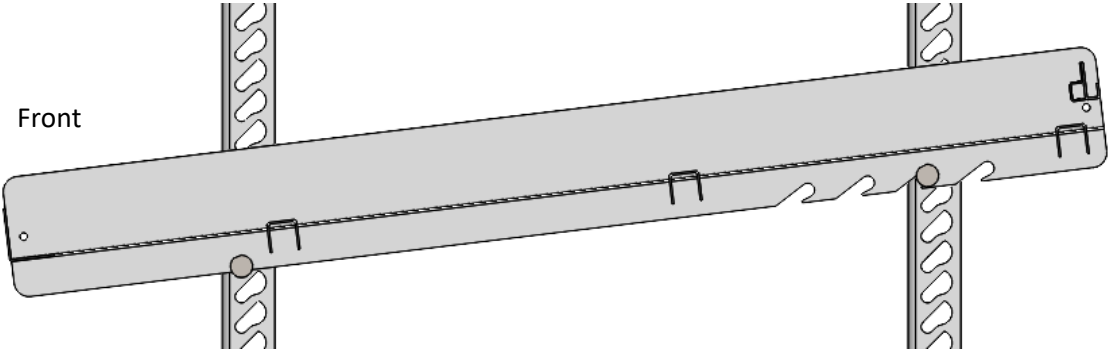

Back

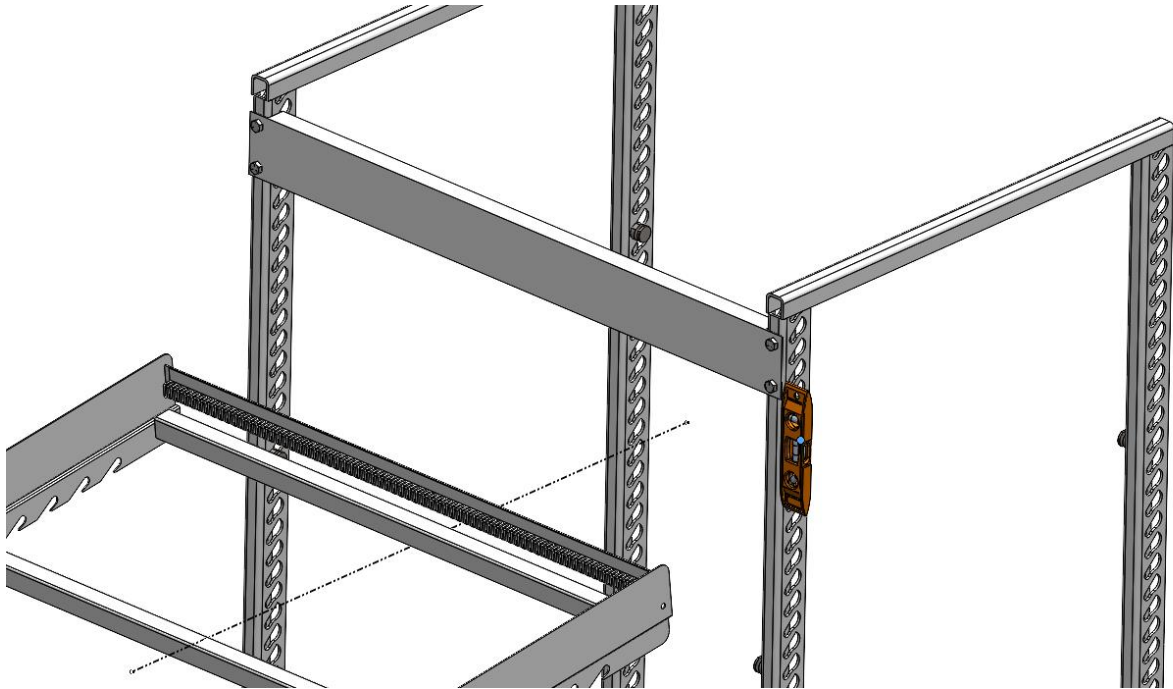

Step 5: **Tighten** all the bolts and nuts using the wrenches.

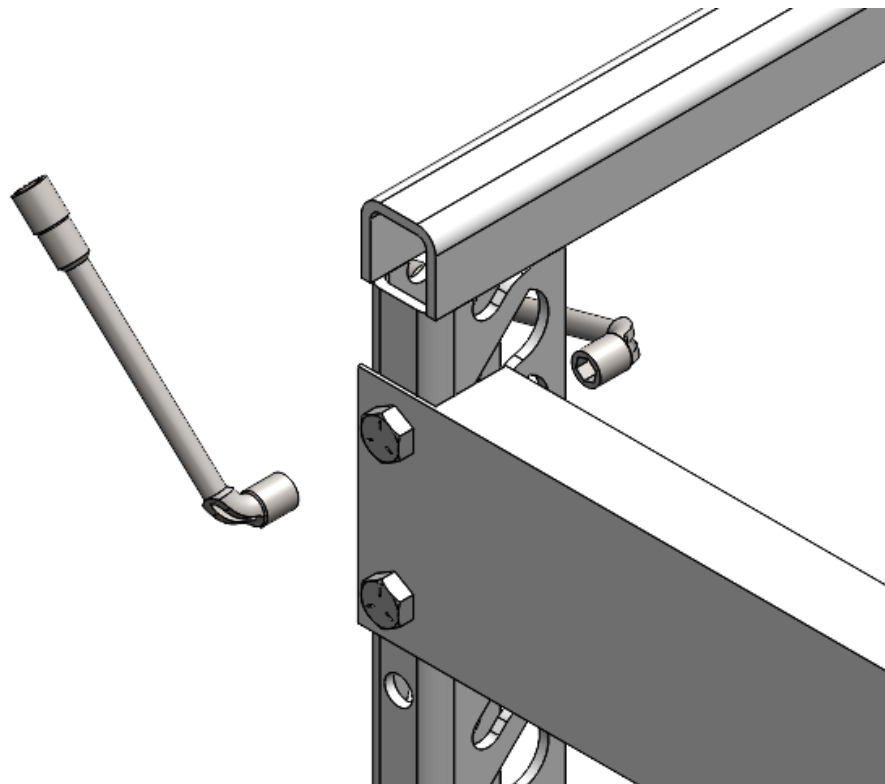

Step 6: Install remaining Shelf Frames.

Shelf Frames

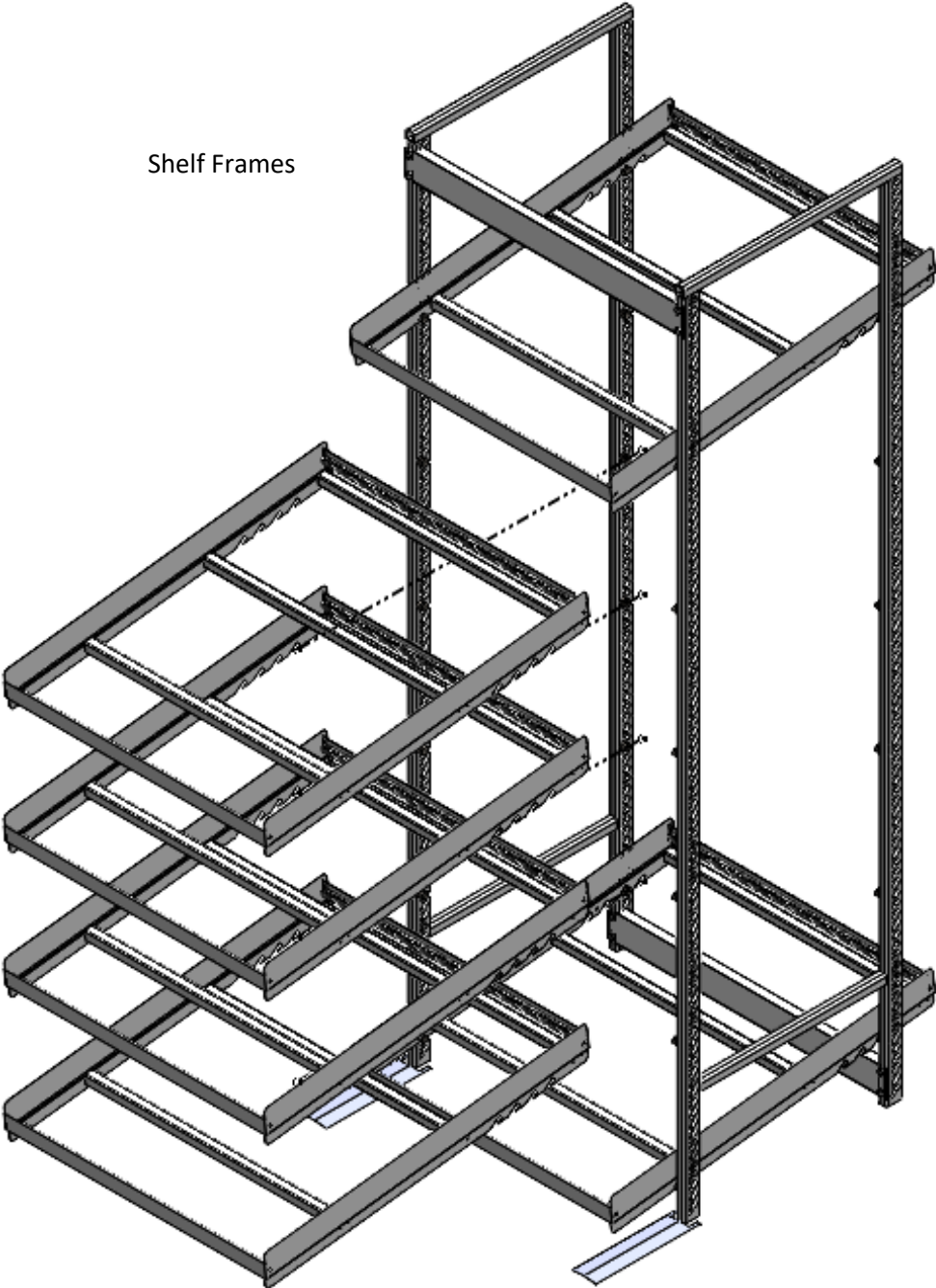

Step 7: Install Front/Rear Price Tag Molding.

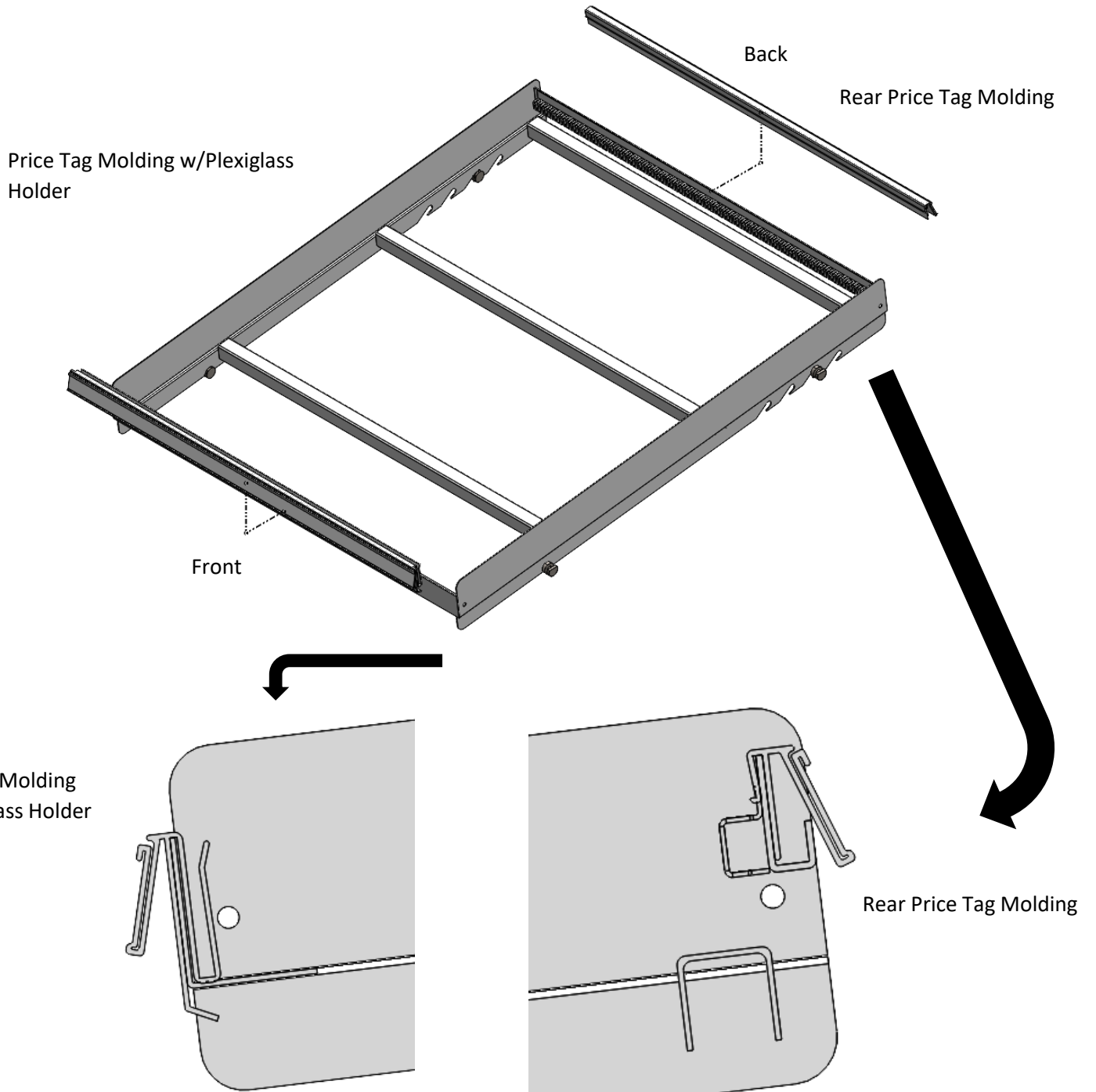

Step 8: Set Grid mat into shelf frame. Put two glide sheets onto each grid mat afterwards.

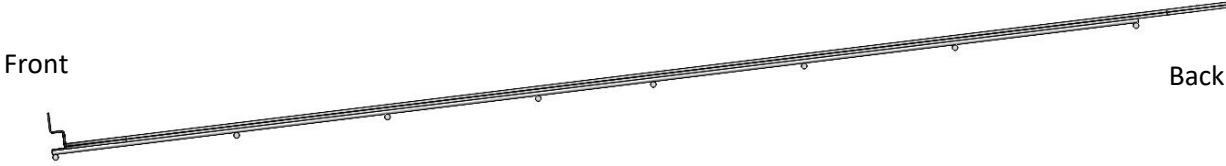
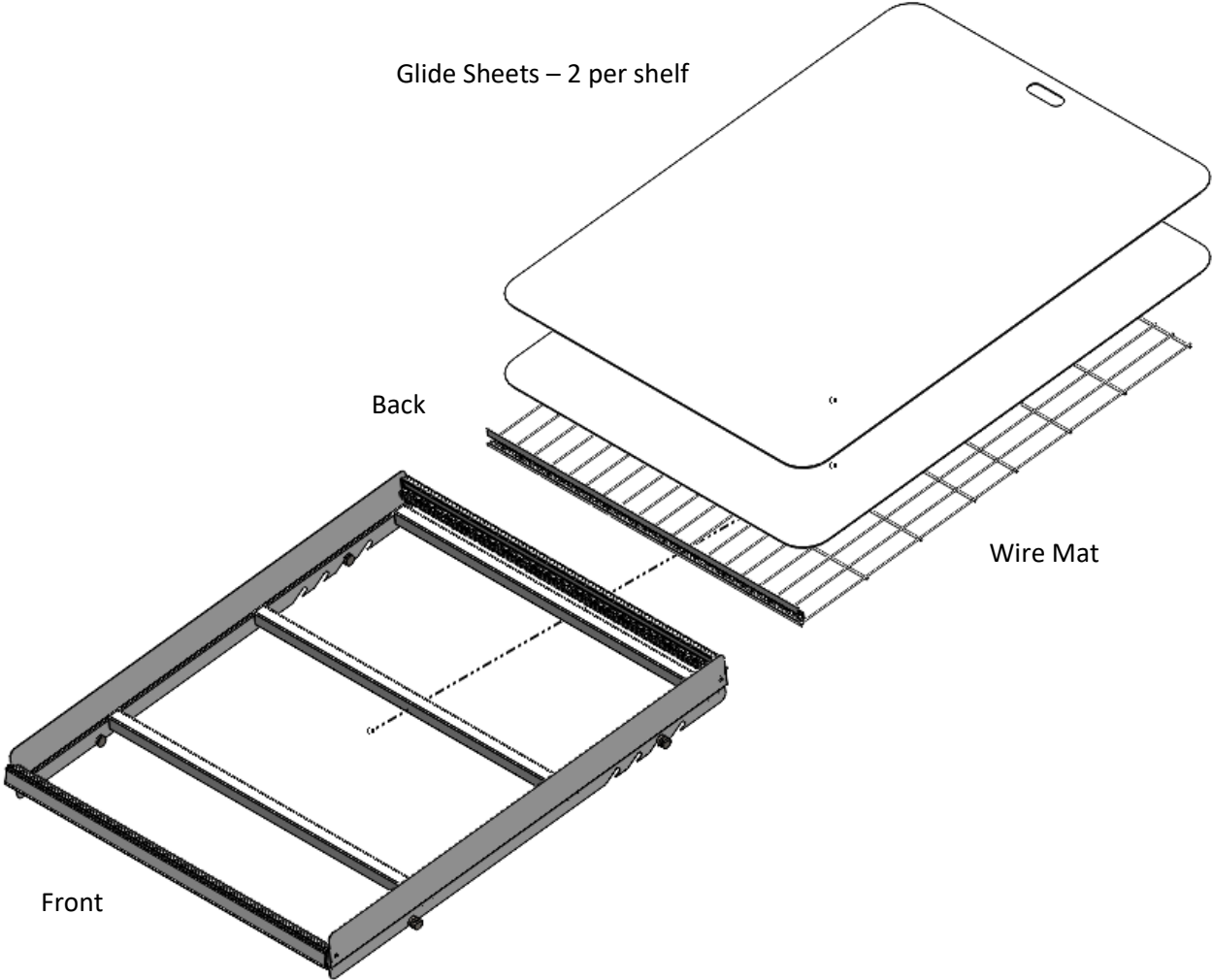

Step 9: Install Lane dividers as needed based upon product displayed.

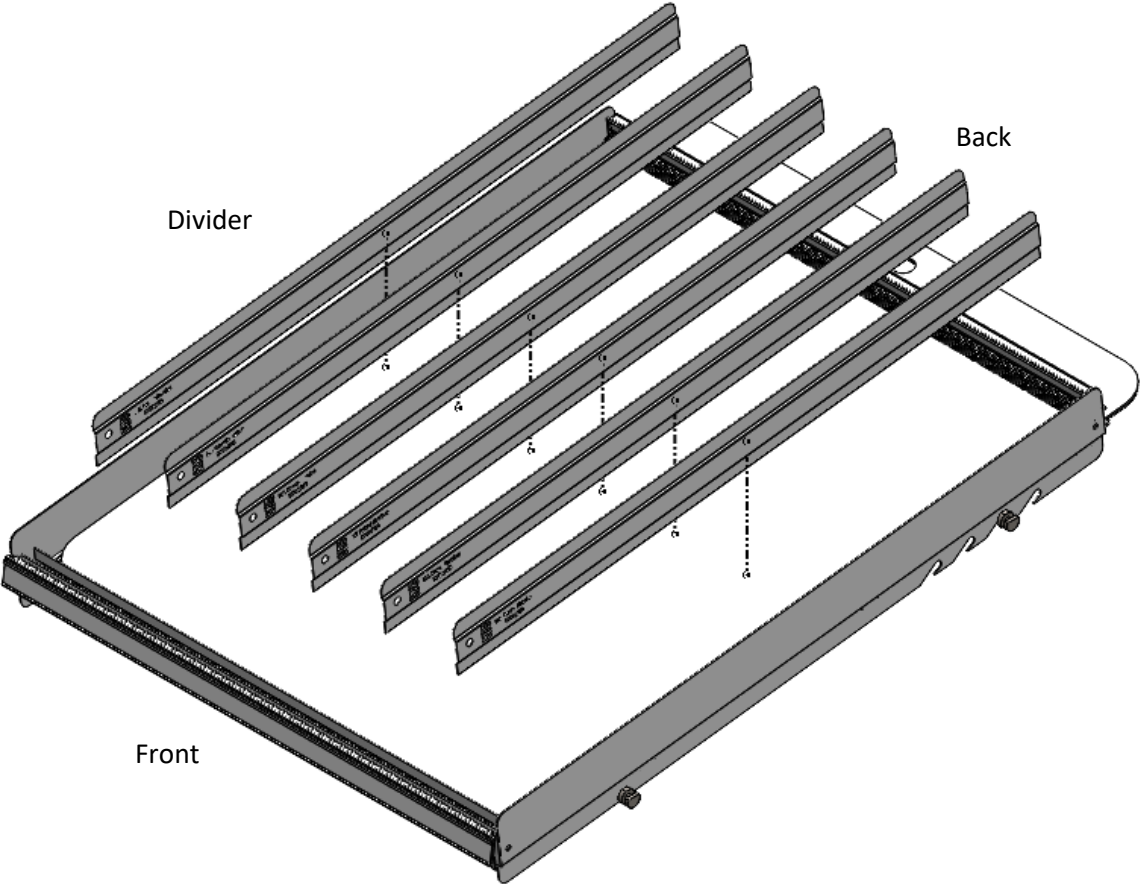

Dividers to be secure in the slots, round side must be up and all indents must go the same way in each shelf

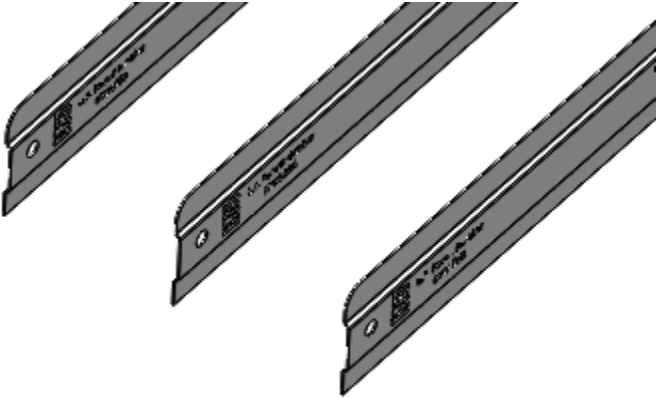

Laying two products down in each lane is a helpful way to set lane dividers.

Step 10: Install Plexiglass front product stop into the Front Price Tag Moldings w/ Plexi Holder slots.

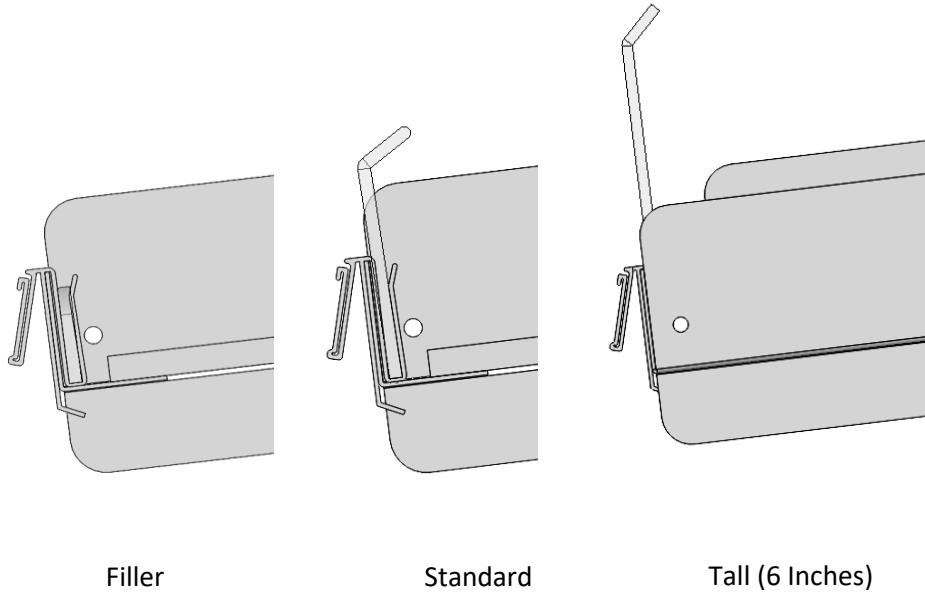
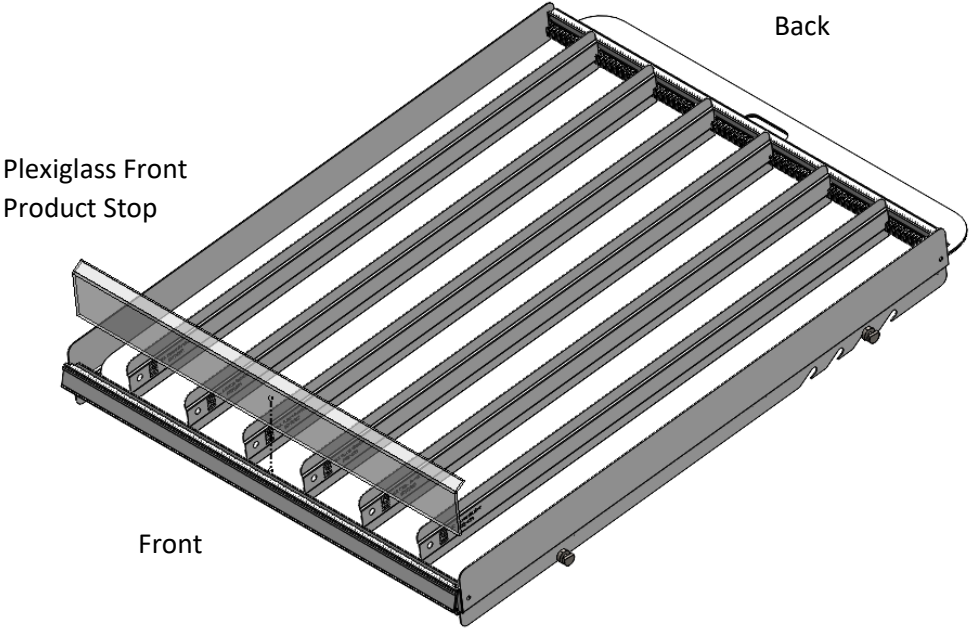

Completed Assembly:

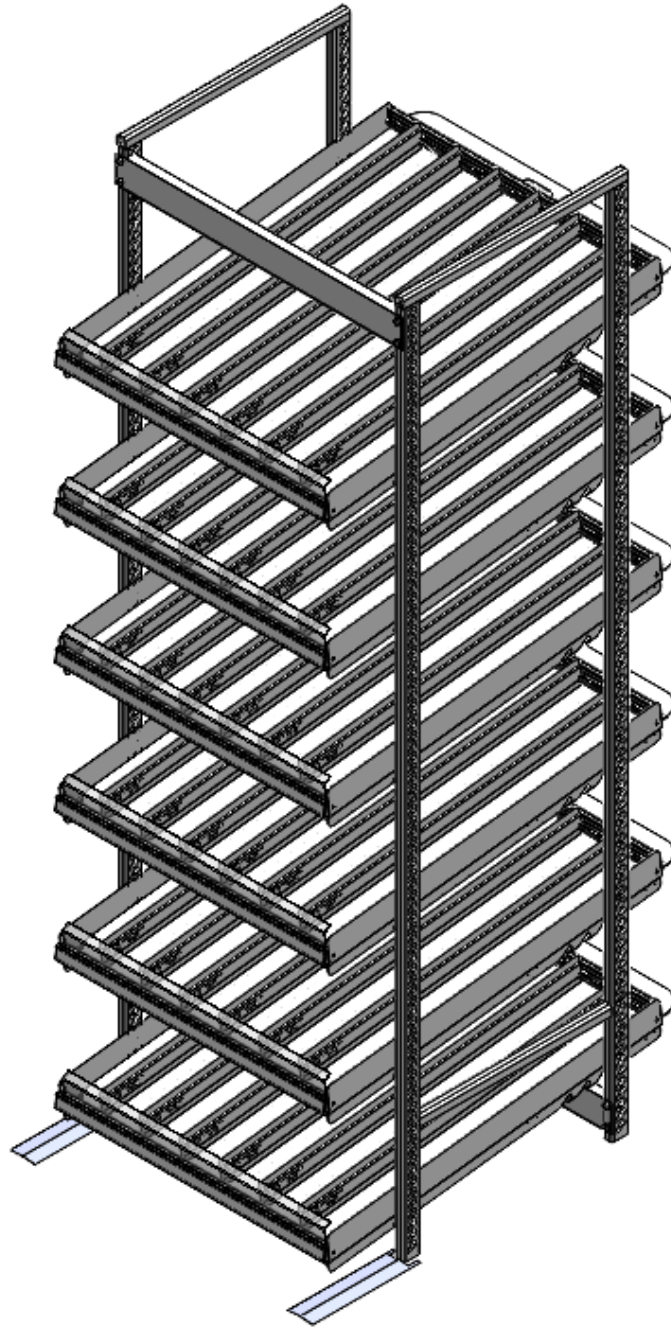

Questions?

Call Customer Service...800-323-2517